

# INSTRUCTIONS

**(545-41100)**

**Pilot Bearing for all V8 and V6  
Chevrolets and V6 Buick**

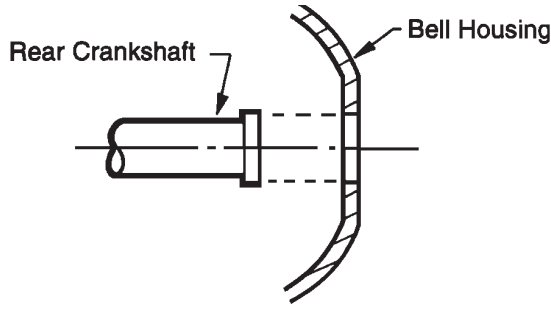

Mounting bore must be concentric with crankshaft centerline within  $\pm .005$ .

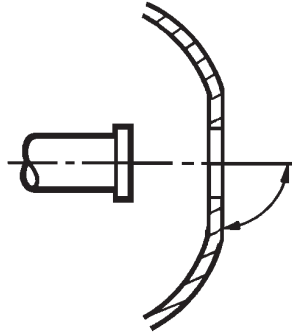

Mounting face must be perpendicular to crankshaft centerline within  $\pm .002$ .

No modification to either crankshaft or input shaft is required. Just remove old pilot bearing and press roller bearing into crankshaft using an arbor press and a 1" O.D. pilot punch. The flat side of the bearing should face the engine with the radius side facing the trans. DO NOT hammer into crankshaft as you are sure to damage bearing.

This bearing comes packed with a high temperature lubricant for high RPM applications. DO NOT wipe or wash out lubricant before use.

For the roller bearing and transmission to operate properly, they must be perfectly in line with the crankshaft. Check the bell housing bore and transmission mounting face with a dial indicator to make sure the bore is concentric with the crankshaft center line and the mounting face is perpendicular to it within  $\pm .002$ .



Speedway Motors Inc., P.O. Box 81906 Lincoln, NE 68501  
[www.speedway.com](http://www.speedway.com)

©2005 Speedway Motors, Inc.

# INSTRUCTIONS

**(545-41100)**

**Pilot Bearing for all V8 and V6  
Chevrolets and V6 Buick**

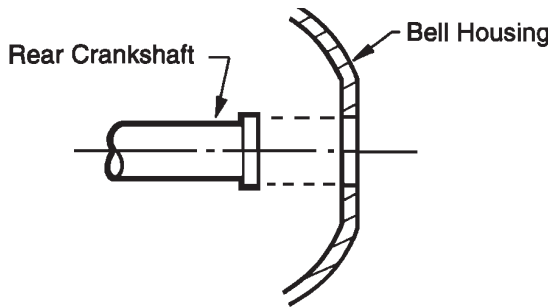

Mounting bore must be concentric with crankshaft centerline within  $\pm .005$ .

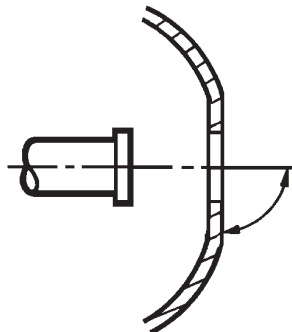

Mounting face must be perpendicular to crankshaft centerline within  $\pm .002$ .

No modification to either crankshaft or input shaft is required. Just remove old pilot bearing and press roller bearing into crankshaft using an arbor press and a 1" O.D. pilot punch. The flat side of the bearing should face the engine with the radius side facing the trans. DO NOT hammer into crankshaft as you are sure to damage bearing.

This bearing comes packed with a high temperature lubricant for high RPM applications. DO NOT wipe or wash out lubricant before use.

For the roller bearing and transmission to operate properly, they must be perfectly in line with the crankshaft. Check the bell housing bore and transmission mounting face with a dial indicator to make sure the bore is concentric with the crankshaft center line and the mounting face is perpendicular to it within  $\pm .002$ .

Speedway Motors Inc., P.O. Box 81906 Lincoln, NE 68501  
[www.speedway.com](http://www.speedway.com)

©2005 Speedway Motors, Inc.

# IMPORTANT

## Shortages May Result From...

**Damage, scratches, breakage, pilferage, or loss in transit.** If this happens, *you should immediately file a claim with the carrier.* When your merchandise leaves our door, we entrust it to the carrier. The carrier assumes all liability.

**Removal of merchandise prior to delivery.** Please check the contents of the carton in the presence of the delivery agent! Be sure to check each item against those listed on the packing slip.

**Mistakenly discarding merchandise with packing material, or overlooking it.** Check content carefully.

Note: All orders shipped are nonreturnable without written permission from Speedway. When requesting a merchandise return, please include the following.

- Reason for merchandise return request
- Invoice number (and purchase order number, if any)
- Date of return request
- Date of purchase

Upon receiving this information and assuming it is correct, permission will then be granted for return. All returned merchandise (except defective, or incorrect shipment) are subject to a 15% handling charge or direct exchange for other parts.

Remember...No allowance will be made for any shortage or damage unless we receive correct notification (see above for details), within fifteen (15) days for delivery.

**Speedway Motors Inc., P.O. Box 81906  
Lincoln, NE 68501 (402) 323-3200  
www.speedwaymotors.com**

## Shortages May Result From...

**Damage, scratches, breakage, pilferage, or loss in transit.** If this happens, *you should immediately file a claim with the carrier.* When your merchandise leaves our door, we entrust it to the carrier. The carrier assumes all liability.

**Removal of merchandise prior to delivery.** Please check the contents of the carton in the presence of the delivery agent! Be sure to check each item against those listed on the packing slip.

**Mistakenly discarding merchandise with packing material, or overlooking it.** Check content carefully.

Note: All orders shipped are nonreturnable without written permission from Speedway. When requesting a merchandise return, please include the following.

- Reason for merchandise return request
- Invoice number (and purchase order number, if any)
- Date of return request
- Date of purchase

Upon receiving this information and assuming it is correct, permission will then be granted for return. All returned merchandise (except defective, or incorrect shipment) are subject to a 15% handling charge or direct exchange for other parts.

Remember...No allowance will be made for any shortage or damage unless we receive correct notification (see above for details), within fifteen (15) days for delivery.

**Speedway Motors Inc., P.O. Box 81906  
Lincoln, NE 68501 (402) 323-3200  
www.speedwaymotors.com**

# IMPORTANT

## IMPORTANT

Legal in California for racing vehicles only, not street legal. Legal only for those vehicles which may never be used upon a highway.

## No Warranty or Guarantee...

### NOTICE TO CONSUMER, DEALER, USER NO WARRANTY, NO GUARANTEE EITHER WRITTEN OR IMPLIED

Neither the seller or the manufacturer will be liable for any loss, damage, or injury direct or indirect arising from the use of or the inability to determine the use of the product. Before using, the user shall determine the suitability of the product for its intended use, and the user shall assume all responsibility and risk in connection therewith.

|           |                |  |
|-----------|----------------|--|
| Axles     | Rods           | Spindles                               |
| Frames    | Bodies         | Arms                                   |
| Brackets  | Adapters       | Seats                                  |
| Fasteners | Steering Parts | Steering Wheels                        |
| Bolts     | Rod Ends       | All suspension parts<br>and components |
| Bushings  | Hubs           |  |

## Speedway Catalog

Speedway Motors' giant catalog contains the nation's largest selection of unique & hard to find street rodding items and hard core racing products. If you don't already have this super buyer's guide, order your personal copy today.



## IMPORTANT

Legal in California for racing vehicles only, not street legal. Legal only for those vehicles which may never be used upon a highway.

## No Warranty or Guarantee...

### NOTICE TO CONSUMER, DEALER, USER NO WARRANTY, NO GUARANTEE EITHER WRITTEN OR IMPLIED

Neither the seller or the manufacturer will be liable for any loss, damage, or injury direct or indirect arising from the use of or the inability to determine the use of the product. Before using, the user shall determine the suitability of the product for its intended use, and the user shall assume all responsibility and risk in connection therewith.

|           |                |  |
|-----------|----------------|--|
| Axles     | Rods           | Spindles                               |
| Frames    | Bodies         | Arms                                   |
| Brackets  | Adapters       | Seats                                  |
| Fasteners | Steering Parts | Steering Wheels                        |
| Bolts     | Rod Ends       | All suspension parts<br>and components |
| Bushings  | Hubs           |  |

## Speedway Catalog

Speedway Motors' giant catalog contains the nation's largest selection of unique & hard to find street rodding items and hard core racing products. If you don't already have this super buyer's guide, order your personal copy today.

