

ASSEMBLY INSTRUCTIONS
FOR
PROMATRIX OE UPGRADE ROTOR KIT, WITH
12.80" DIAMETER VENTED ROTOR, FRONT
12.00" DIAMETER VENTED ROTOR, REAR
1997-2004 CHEVROLET C-5 CORVETTE
2005-PRESENT CHEVROLET C-6 CORVETTE (BASE MODEL*)

PART NUMBER GROUP

140-9336

**DISC BRAKES SHOULD ONLY BE INSTALLED BY SOMEONE
EXPERIENCED AND COMPETENT IN THE INSTALLATION AND
MAINTENANCE OF DISC BRAKES**
READ ALL WARNINGS

WARNING

IT IS THE RESPONSIBILITY OF THE PERSON INSTALLING ANY BRAKE COMPONENT OR KIT TO DETERMINE THE SUITABILITY OF THE COMPONENT OR KIT FOR THAT PARTICULAR APPLICATION. IF YOU ARE NOT SURE HOW TO SAFELY USE THIS BRAKE COMPONENT OR KIT, YOU SHOULD NOT INSTALL OR USE IT. DO NOT ASSUME ANYTHING. IMPROPERLY INSTALLED OR MAINTAINED BRAKES ARE DANGEROUS. IF YOU ARE NOT SURE, GET HELP OR RETURN THE PRODUCT. YOU MAY OBTAIN ADDITIONAL INFORMATION AND TECHNICAL SUPPORT BY CALLING WILWOOD AT (805) 388-1188, OR VISIT OUR WEB SITE AT WWW.WILWOOD.COM. USE OF WILWOOD TECHNICAL SUPPORT DOES NOT GUARANTEE PROPER INSTALLATION. **YOU**, OR THE PERSON WHO DOES THE INSTALLATION MUST KNOW HOW TO PROPERLY USE THIS PRODUCT. IT IS NOT POSSIBLE OVER THE PHONE TO UNDERSTAND OR FORESEE ALL THE ISSUES THAT MIGHT ARISE IN YOUR INSTALLATION.

RACING EQUIPMENT AND BRAKES MUST BE MAINTAINED AND SHOULD BE CHECKED REGULARLY FOR FATIGUE, DAMAGE, AND WEAR.



Need Additional Information?
Use Your SmartPhone and
Jump to Our Technical Tips
Section on Our Web Site.



WARNING

DO NOT OPERATE ANY VEHICLE ON UNTESTED BRAKES!
SEE MINIMUM TEST PROCEDURE WITHIN

ALWAYS UTILIZE SAFETY RESTRAINT SYSTEMS AND ALL OTHER AVAILABLE SAFETY EQUIPMENT WHILE OPERATING THE VEHICLE

IMPORTANT • READ THE DISCLAIMER OF WARRANTY INCLUDED IN THE KIT

NOTE: Some cleaners may stain or remove the finish on brake system components. Test the cleaner on a hidden portion of the component before general use.

*WILL NOT FIT C-6 Z06 OR Z51 MODEL SUSPENSIONS

Important Notice - Read This First

Before any tear-down or disassembly begins, review the following information:

- Due to OEM production differences and other variations from vehicle to vehicle, the fastener hardware and other components in this kit may not be suitable for a specific application or vehicle.
- It is the responsibility of the purchaser and installer of this kit to verify suitability / fitment of all components and ensure all fasteners and hardware achieve complete and proper engagement. Improper or inadequate engagement can lead to component failure.

Photographic Tip

Important and highly recommended: Take photos of brake system before disassembly and during the disassembly process. In the event, trouble-shooting photos can be life savers. Many vehicles have undocumented variations, photos will make it much simpler for Wilwood to assist you if you have a problem.

Exploded Assembly Diagram and Parts List

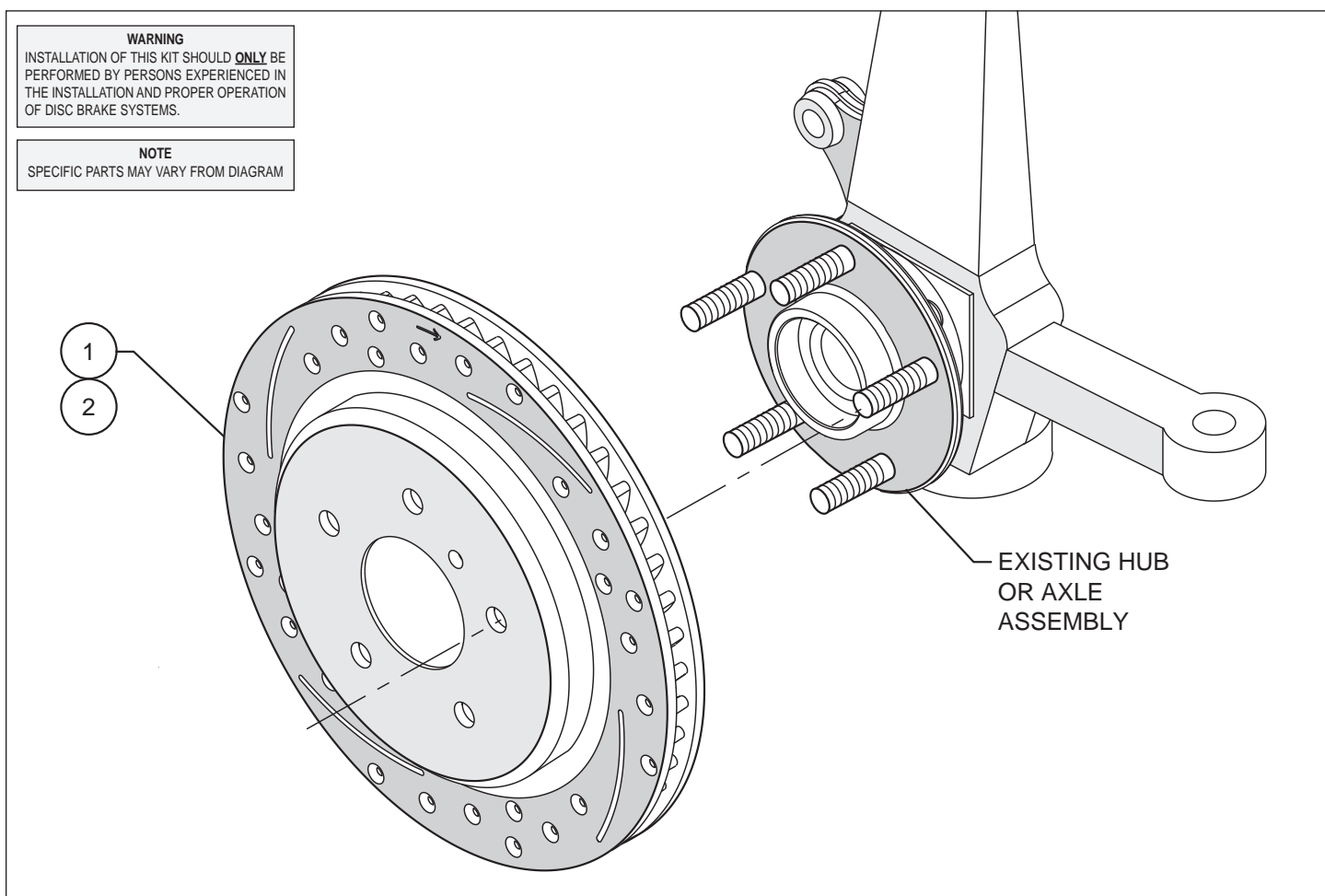

Figure 1. Typical Installation Configuration

<u>ITEM NO.</u>	<u>PART NO.</u>	<u>DESCRIPTION</u>	<u>QTY</u>
1	160-9334/35	Rotor, Front, SRP Drilled and Slotted - 1.25" x 12.80" Dia, 5 x 4.75" BC (one each, right and left hand)	2
2	160-7767/68	Rotor, Rear, SRP Drilled and Slotted - 1.03" x 12.00" Dia, 5 x 4.75" BC (one each, right and left hand)	2

General Information, Disassembly, and Assembly Instructions

Installation of this kit should **ONLY** be performed by persons experienced in the installation and proper operation of disc brake systems. Before installation begins, please read the complete procedure thoroughly to familiarize yourself with the process, and double check the following items to ensure a trouble-free installation.

- Make sure this is the correct kit to fit the exact make and model year. This kit is specifically designed as a direct bolt-on OE replacement for Chevrolet C-5 Corvette's, model years 1997 - 2004 and Chevrolet C-6 Corvette's, model years 2005 - present. These rotors will not fit C-6 Z06 or Z51 model suspensions.
- Verify the hub/axle flange and stud pattern in this kit matches the stud pattern of the vehicle's wheels.
- Inspect the package contents against the parts list to ensure that all components are included.

Disassembly Instructions

- Disassemble the original equipment front and rear brakes:
Raise the front and rear wheels off the ground and support the suspension according to the vehicle manufacturer's instructions.

Remove the wheel. Remove the bolts that hold the stock caliper to the stock caliper mounting bracket. Remove the caliper and hang off to the side using a piece of wire. Remove brake pads from bracket. Slide off the rotor assembly. Remove all nicks or burrs on the hub/axle flange face or registration diameter.

Assembly Instructions (numbers in parenthesis refer to the part list/diagram on the preceding page):

- Align the hole pattern on the rotor (1 or 2) with the stud pattern on the hub (front) or axle flange (rear). Slide the rotor onto the hub or axle flange. Check to be sure the rotor seats squarely against the hub/axle flange face. The hub/axle flange must be free from any rust, debris, casting burrs, machining irregularities, etc. Use several lug nuts to hold the rotor firmly against the hub/axle flange face.
- Install brake pads into stock caliper bracket. **NOTE:** For best performance and service life, Wilwood recommends using new brake pads with new replacement rotors. Please see the Associated Components section on page 4 for Wilwood performance and racing pad applications.
- Bolt the caliper onto the bracket in the original configuration.
- Torque the caliper mounting bolts to manufacturer's specifications.
- Bleed the brake system, referring to additional information below as necessary.
- Remove the lug nuts that were holding the rotor in place. Install the wheel and torque the lug nuts to manufacturer's specification. Check to see that the wheel rotates freely without interference.

Additional Information and Recommendations

- Fill and bleed the new system with Wilwood Hi-Temp[®] 570 grade fluid or higher. For severe braking or sustained high heat operation, use Wilwood EXP 600 Plus Racing Brake Fluid. Used fluid must be completely flushed from the system to prevent contamination. **NOTE:** Silicone DOT 5 brake fluid is **NOT** recommended for racing or performance driving.
- Properly bleed the brake system according to the vehicle manufacturer's instructions, generally beginning with the caliper farthest from the master cylinder. **NOTE:** When using a new master cylinder, it is important to bench bleed the master cylinder first.
- Test the brake pedal. It should be firm, not spongy and stop at least 1 inch from the floor under heavy load.
If the brake pedal is spongy, bleed the system again.

If the brake pedal is initially firm, but then sinks to the floor, check the system for fluid leaks. Correct the leaks (if applicable) and then bleed the system again.
- NOTE:** With the installation of after market disc brakes, the wheel track may change depending on the application. Check your wheel offset before final assembly.
- If after following the instructions, you still have difficulty in assembling or bleeding your Wilwood disc brakes, consult your local chassis builder, or retailer where the kit was purchased for further assistance.

Brake Testing

WARNING • DO NOT DRIVE ON UNTESTED BRAKES BRAKES MUST BE TESTED AFTER INSTALLATION OR MAINTENANCE MINIMUM TEST PROCEDURE

- Make sure pedal is firm: Hold firm pressure on pedal for several minutes, it should remain in position without sinking. If pedal sinks toward floor, check system for fluid leaks. DO NOT drive vehicle if pedal does not stay firm or can be pushed to the floor with normal pressure.
- At very low speed (2-5 mph) apply brakes hard several times while turning steering from full left to full right, repeat several times. Remove the wheels and check that components are not touching, rubbing, or leaking.
- Carefully examine all brake components, brake lines, and fittings for leaks and interference.
- Make sure there is no interference with wheels or suspension components.
- Drive vehicle at low speed (15-20 mph) making moderate and hard stops. Brakes should feel normal and positive. Again check for leaks and interference.
- Always test vehicle in a safe place where there is no danger to (or from) other people or vehicles.
- Always wear seat belts and make use of all safety equipment.

Pad and Rotor Bedding

BEDDING STEPS FOR NEW PADS AND ROTORS – ALL COMPOUNDS

Once the brake system has been tested and determined safe to operate the vehicle, follow these steps for the bedding of all new pad materials and rotors. These procedures should only be performed on a race track, or other safe location where you can safely and legally obtain speeds up to 65 MPH, while also being able to rapidly decelerate.

- Begin with a series of light decelerations to gradually build some heat in the brakes. Use an on-and-off the pedal technique by applying the brakes for 3-5 seconds, and then allow them to fully release for a period roughly twice as long as the deceleration cycle. If you use a 5 count during the deceleration interval, use a 10 count during the release to allow the heat to sink into the pads and rotors.
- After several cycles of light stops to begin warming the brakes, proceed with a series of medium to firm deceleration stops to continue raising the temperature level in the brakes.
- Finish the bedding cycle with a series of 8-10 hard decelerations from 55-65 MPH down to 25 MPH while allowing a proportionate release and heat-sinking interval between each stop. The pads should now be providing positive and consistent response.
- If any amount of brake fade is observed during the bed-in cycle, immediately begin the cool down cycle.
- Drive at a moderate cruising speed, with the least amount of brake contact possible, until most of the heat has dissipated from the brakes. Avoid sitting stopped with the brake pedal depressed to hold the car in place during this time. Park the vehicle and allow the brakes to cool to ambient air temperature.

COMPETITION VEHICLES

- If your race car is equipped with brake cooling ducts, blocking them will allow the pads and rotors to warm up quicker and speed up the bedding process.
- Temperature indicating paint on the rotor and pad edges can provide valuable data regarding observed temperatures during the bedding process and subsequent on-track sessions. This information can be highly beneficial when evaluating pad compounds and cooling efficiencies.

Pad and Rotor Bedding (Continued)

POST-BEDDING INSPECTION – ALL VEHICLES

- After the bedding cycle, the rotors should exhibit a uniformly burnished finish across the entire contact face. Any surface irregularities that appear as smearing or splotching on the rotor faces can be an indication that the brakes were brought up to temperature too quickly during the bedding cycle. If the smear doesn't blend away after the next run-in cycle, or if chatter under braking results, sanding or resurfacing the rotors will be required to restore a uniform surface for pad contact.

PRE-RACE WARM UP

- Always make every effort to get heat into the brakes prior to each event. Use an on-and-off the pedal practice to warm the brakes during the trip to the staging zone, during parade laps before the flag drops, and every other opportunity in an effort to build heat in the pads and rotors. This will help to ensure best consistency, performance, and durability from your brakes.

DYNO BEDDED COMPETITION PADS AND ROTORS

- Getting track time for a proper pad and rotor bedding session can be difficult. Wilwood offers factory dyno-bedded pads and rotors on many of our popular competition pads and **Spec 37** GT series rotors. Dyno-bedded parts are ready to race on their first warm up cycle. This can save valuable time and effort when on-track time is either too valuable or not available at all, Dyno-bedding assures that your pads and rotors have been properly run-in and are ready to go. Contact your dealer or the factory for more information on Wilwood Dyno-Bedding services.

NOTE:

NEVER allow the contact surfaces of the pads or rotors to be contaminated with brake fluid. Always use a catch bottle with a hose to prevent fluid spill during all brake bleeding procedures.

Connect with Wilwood

Wilwood Social Forum



Wilwood Facebook



Wilwood Twitter



Wilwood YouTube



Associated Components

<u>PART NO.</u>	<u>DESCRIPTION</u>
15E-7441K	PolyMatrix D732 "E" compound pads, C5 rear (medium temp)
15E-7442K	PolyMatrix D731 "E" compound pads, C5 front (medium temp)
15H-8599K	PolyMatrix D732 "H" compound pads, C5 rear (high temperature race only)
15H-8600K	PolyMatrix D731 "H" compound pads, C5 front (high temperature race only)
15J-6016K	PolyMatrix D732 "J" compound pads, C5 rear (high temperature race only)
15J-6017K	PolyMatrix D731 "J" compound pads, C5 front (high temperature race only)
15Q-8011K	PolyMatrix D732 "Q" compound pads, C5 rear (low to medium temperature)
15Q-8012K	PolyMatrix D731 "Q" compound pads, C5 front (low to medium temperature)
220-8021	Flexline kit, Corvette C5 front. OE replacement
220-8072	Flexline kit, Corvette C5 rear, OE replacement
290-0632	Brake fluid, Wilwood Hi-Temp ^o 570, 12 oz bottle
290-6210	Brake fluid, EXP 600 Plus, 16.5 oz bottle