



QUALITY... PLAIN & SIMPLE®

## Hood & Trunk Release Cable Installation Instructions

### General Installation Notes:

Please read these instructions completely before beginning the installation. If you have any questions please call.

Before beginning the installation, disconnect the negative battery cable and use wheel chocks to block the vehicle's wheels.

Make sure the engine, transmission, body and frame are properly grounded. We recommend using anti-seize lubricant on all aluminum threads.

**NOTE:** Trunk release cables have a 1-piece housing, and hood release cables have a 2-piece housing that is split at the firewall. If you are installing a trunk release cable, you will **NOT** need to perform the steps marked "**HOOD RELEASE ONLY**" below.

If you are installing a right-hand release cable kit, the procedure is the same as outlined below, but the release handle assembly is a mirror image of the ones pictured in these instructions.

The release handle assembly needs to be firmly attached to a sturdy, flat surface on the vehicle. It may be necessary to fabricate a bracket for the release handle assembly to mount to.

**Step 1: ALL:** Remove the cable end stop and cable adjuster from the end of the inner wire. If the cable has a black universal housing, remove the ferrule. If the cable has a stainless steel housing, **DO NOT** remove the ferrule. **Fig. 1**

**Step 2: ALL:** Pull the outside arm back as far as it will go. Pull the inner wire out of the cable housing, and then pull it out of the outside arm. **Fig. 2**

**NOTE:** Do not remove the outside arm pivot bolt or the outside arm from the release handle assembly.

**Step 3: HOOD RELEASE ONLY:** Unscrew the outside firewall fitting from the inside firewall fitting. **Fig. 3**

**Step 4: HOOD RELEASE ONLY:** Determine where you want the release handle assembly and the firewall hole to be located. The release handle assembly should be mounted 24" or less from the hole in the firewall. Keep in mind that the cable housing cannot be bent sharply, and any curves that you make with the cable housing will reduce the distance it reaches. Test fit the cable housing before drilling any holes, to make sure the cable housing is not bent too sharply and that it will reach the firewall hole.

# Hood & Trunk Release Cable Installation Instructions

Building American Quality... With A Lifetime Warranty!®

TOLL FREE 1-877-469-7440 • tech@lokar.com • www.lokar.com

### Step 4: (continued)

If you need to mount the release handle assembly more than 24" from the hole in the firewall, a custom length inner wire and cable housing will be required. If the release handle assembly is to be mounted close to the firewall and the cable housing is too long, it may be cut to fit. Loosen the two flat head bolts that attach the flat cap to the release handle assembly and pull out the cable housing (**Fig. 2**).

### Make sure that the inner wire has been removed from the cable housing.

If the cable housing is braided stainless steel, wrap tape around the area to be cut and use a cutoff wheel or fine-toothed hacksaw. If the cable has a black universal housing, cut the cable housing with heavy duty 8" diagonal cutting pliers or a hacksaw. Lokar recommends Klein brand Diagonal Cutting Pliers, #D2000-28 available at The Home Depot or through W. W. Graingers, Part #4A838. Reassemble the cable housing to the release handle assembly and test fit again.

**Step 5: ALL:** Route the cable housing where you want it to go and make sure it will reach the latch. Make sure the cable housing is not too close to the exhaust and will not interfere with any moving parts. The Lokar release cable requires a mount bracket (not supplied) that will support the cable housing approximately 3" from the connection point at the latch release lever. The ferrule on the cable housing needs to end approximately 1" before reaching the mount bracket (or 4" short of the connection point on the release lever). **Fig. 4**

**NOTE:** The Lokar Hood and Trunk Release Cable Kit is universal in application, and the dimensions listed above are meant to be general guidelines only.

If the cable housing does not reach the latch, you will need to order a custom-length cable housing and inner wire. If the cable housing is too long, it may be cut to fit.

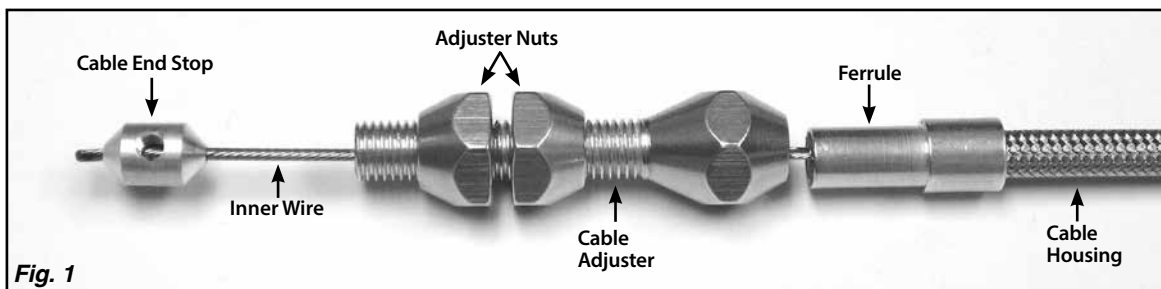

Fig. 1

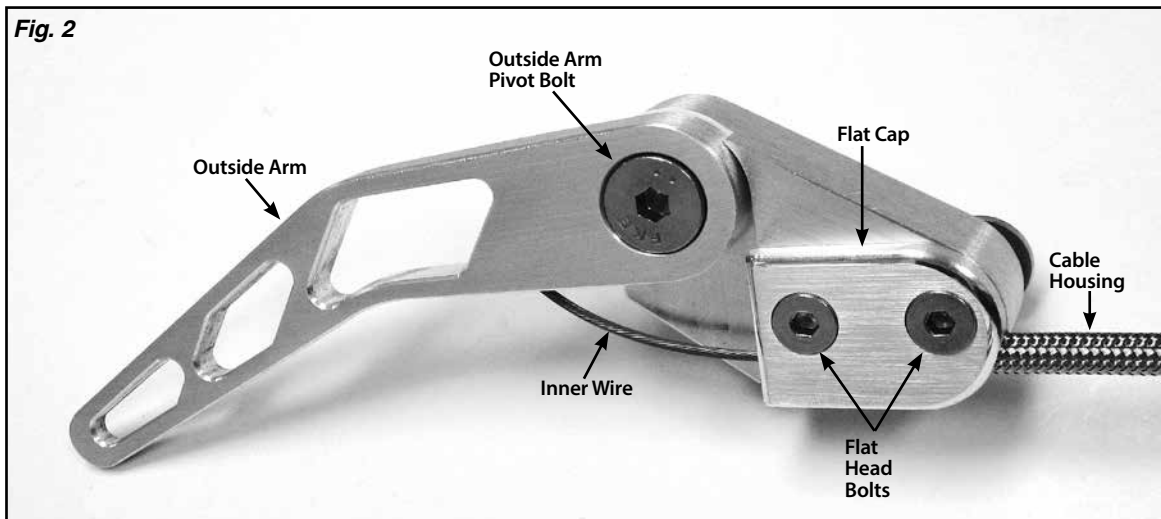

Fig. 2

## Hood & Trunk Release Cable Installation Instructions

If the cable housing is braided stainless steel, slide the ferrule up the housing towards the firewall (or towards the release handle assembly), above where you will be cutting the cable housing. **Make sure that the inner wire has been removed from the cable housing.** Wrap tape around the area to be cut and use a cutoff wheel or fine-toothed hacksaw. If the cable has a black universal housing, cut the cable housing with heavy duty 8" diagonal cutting pliers or a hacksaw. Lokar recommends Klein brand Diagonal Cutting Pliers, # D2000-28 available at The Home Depot or through W. W. Graingers, Part #4A838. Test fit again after cutting.

**Step 6: HOOD RELEASE ONLY:** Once you have verified that both cable housings are the correct length, drill a 5/16" hole in the firewall at the spot you decided on earlier.

**Step 7: HOOD RELEASE ONLY:** This step will require two people in most cases. Insert the outside firewall fitting into the firewall hole from the engine compartment. From inside the passenger compartment, separate the cable housing from the release handle assembly again. Thread the inside firewall fitting and cable housing onto the outside firewall fitting, and tighten. Reinstall the cable housing into the release handle assembly.

**Step 8: ALL:** Mount the release handle assembly at the spot you decided on earlier, using the two 1/4"-20 x 5/8" hex head bolts with flat washers (supplied), **Fig. 5**. If the release handle assembly is not at the correct angle, do not twist the cable housing! Loosen the two flat head bolts that attach the flat cap to the release handle assembly (**Fig. 2**), twist the release handle assembly to the correct orientation, and tighten the flat head bolts.



Fig. 3

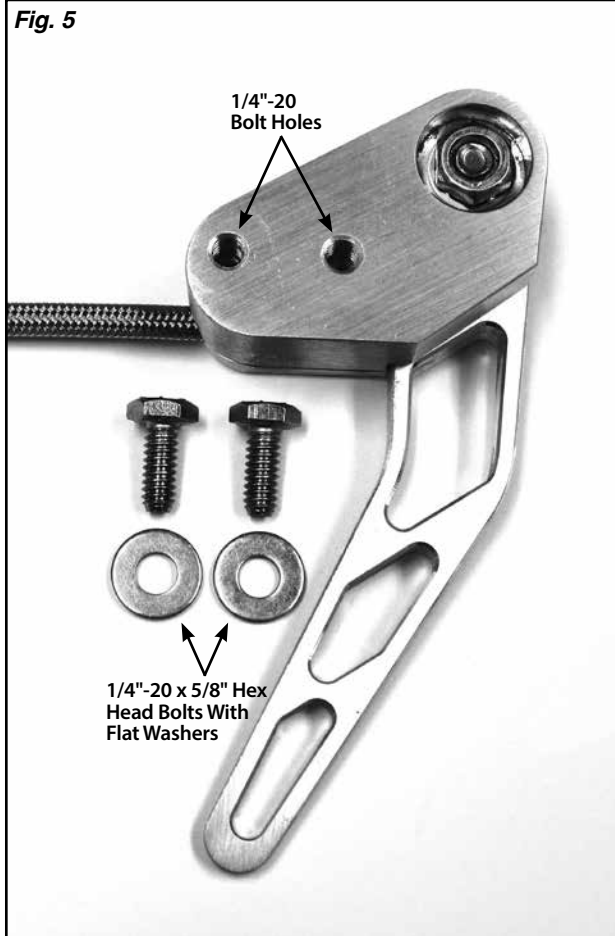

Fig. 5

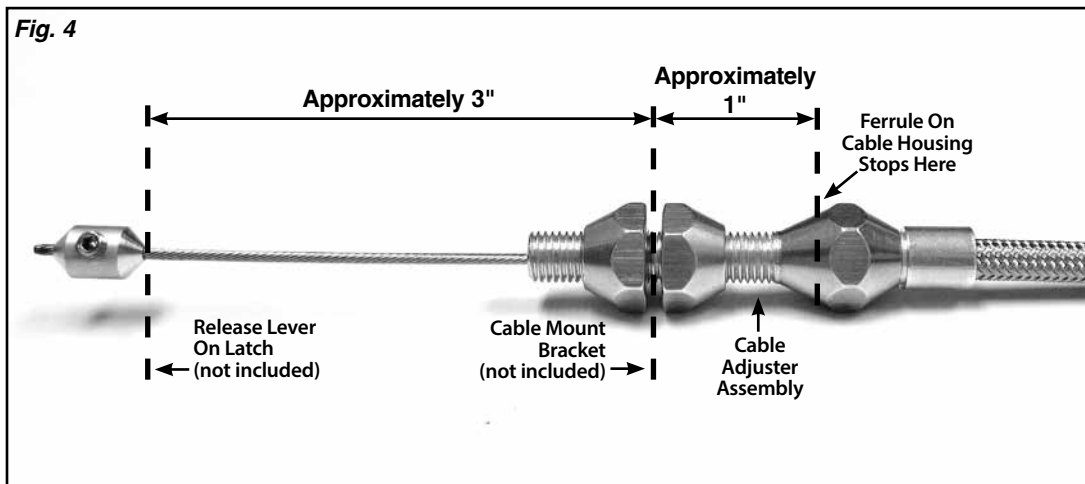

Fig. 4

**Step 9: ALL:** Route the cable housing to the latch. Install the cable adjuster into the cable support mount bracket (not supplied) at the latch. Position the ferrule at the end of the cable housing, and insert the cable housing and ferrule into the cable adjuster.

**Step 10: ALL:** At the release handle assembly, pull the outside arm out as far as it will go. Thread the inner wire fully through the outside arm. Then thread the inner wire fully into the cable housing and move the release outside arm to its normal position.

**Step 11: ALL:** Thread the inner wire through the release lever on the latch. Install the cable end stop onto the inner wire, and slide it up against the release lever on the latch. Pull the inner wire tight, and tighten the set screw on the cable stop using the supplied hex wrench.

**Step 12: ALL:** Check operation of release cable mechanism. Adjust as necessary. Once the release cable is adjusted and the latch is releasing properly, cut off the excess inner wire using wire cutters.

**NOTE: COMBINATION HOOD AND TRUNK RELEASE CABLE KITS:** This kit has a release handle assembly with both an inside arm and an outside arm. The two cables are separated by a spacer block. The installation procedure will be the same as above. The outside arm is intended to be for the hood release, and the inside arm is intended to be for the trunk release, but this may be reversed by swapping the cable housings if you so choose.

Fig. 6

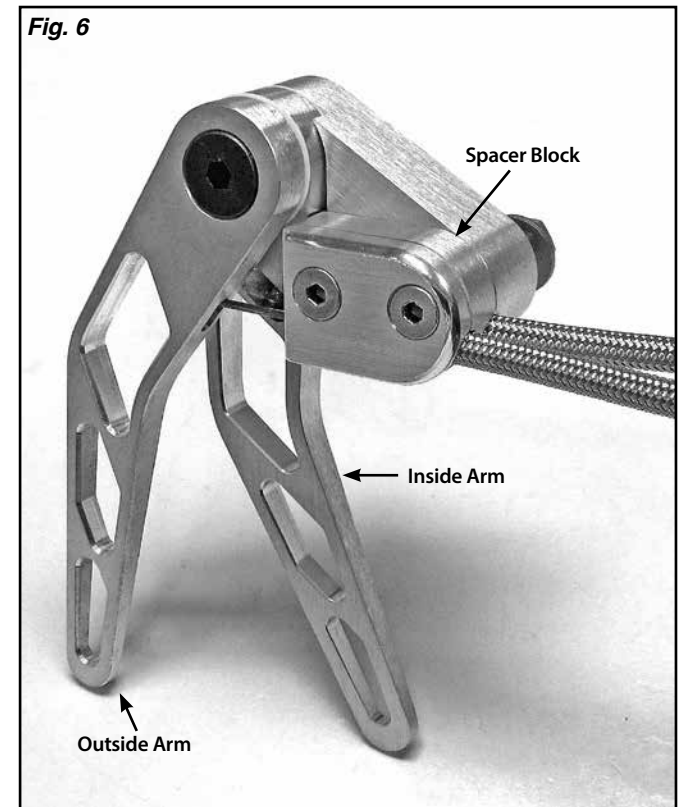

Fig. 6