

17

Then go to finer grits ending up in 600 grit. Do this along with any filler work needed.

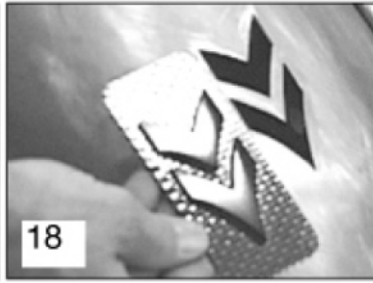

18

To finish the lenses they will need to be polished. To eliminate white light from showing around the red you can black out the lens before polishing.

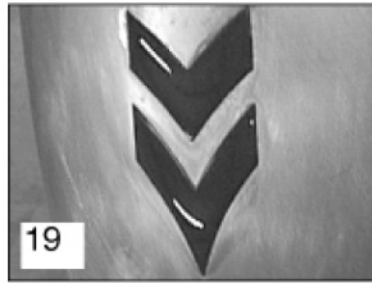

19

With the black paint dry install the lens and boxes again. Now polish the lens the same way you would polish the clear coat. The black will buff right off. Once the lenses are polished remove, clean and store for final assembly.

WIRING

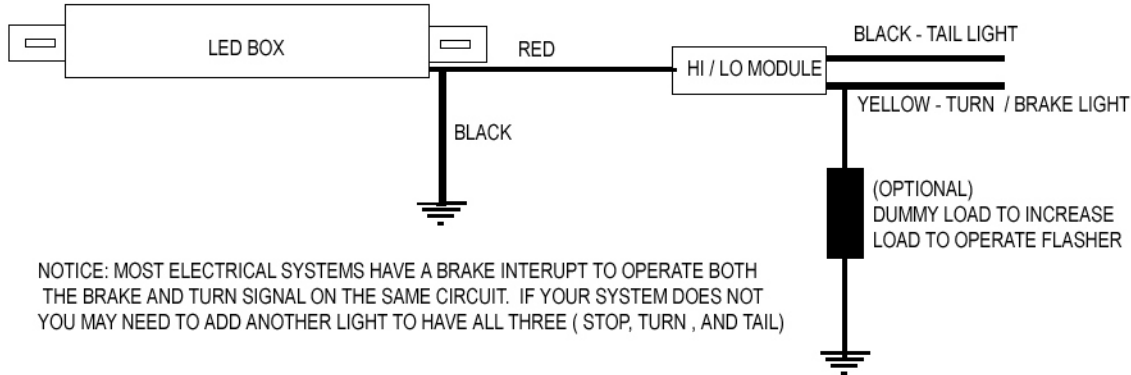

SHAPING THE LENSES

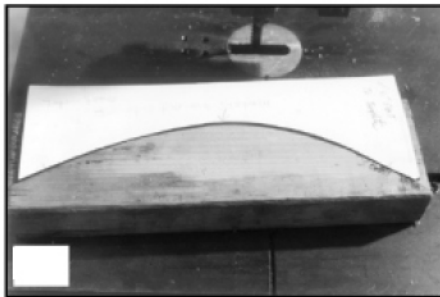

Make a template of the curve in the panel and cut it out of a block of wood.



Clamp the lens as shown.



Slowly apply heat with a heat gun at the area in contact with the wood. Work the lens gently. Too fast will destroy the lens.



Once lens is against the block, cool with water.

Hagan Street Rods
721 W. Monroe St.
New Bremen, Ohio 45869
419-629-1969