

INSTRUCTIONS

916-39001

916-39003

916-39105

916-39106

**GENERAL INSTALLATION FOR FORD "A",
'32,'33, AND '34 FOUR BAR SUSPENSION**

©Speedway Motors, Inc. 2014

SPEEDWAY'S FOUR BAR KIT

1. Assemble the axle, spring perches, shackles, bat wings, and spring using only the main and second leaf spring. This will set the front end in an approximate riding position. Next, clamp the spring in the crossmember.
2. Square the front axle with a reference point somewhere on the rear of the frame. Hint flip the frame upside down for easy installation of the four bar kit. If not possible, use the same procedure.
3. Install the four-bar tubes into the batwing end that connects to the frame brackets. If using Mustang steering, start with that side first. The steering bracket may have to be ground to fit properly along the side of the frame rail. Once fitted, tack in place. Tack the right side the same as the left. Be sure to adjust the rod ends so no more than 3/8" of the thread is showing.
4. Measure the distance between the holes on the batwing bracket. Measure and mark that same distance from the center of the bushing on the frame bracket and scribe a line on the frame. Next, attach the four-bar tubes to the batwings that are to be mounted to the frame. Hold the adjustable end to the frame and center your scribe line in the bushing. Scribe around the inside. Center punch a 1/4" hole.
5. When drilling through the frame, care must be taken to get the hole drilled on the same angle as the frame bracket you have just installed. Do this by inserting one of the bolts for the four-bar end into the bracket. This will give you a visual to go by. Hole saw a 7/8" hole for the 1/8" steel bushing supplied with the kit. Weld into place, as shown in drawing.
6. On the final assembly, remember that without the weight of your engine, your frame will sit a couple of inches higher, and would appear that the adjuster on the radius rods would have to be screwed out to reach the frame. When your car is completed and you are ready to set the tow in, be sure to re-adjust the ends to about 3/8" of the exposed thread. This will be a good place to start from, as a couple of turns will change the caster from a half degree to one degree.

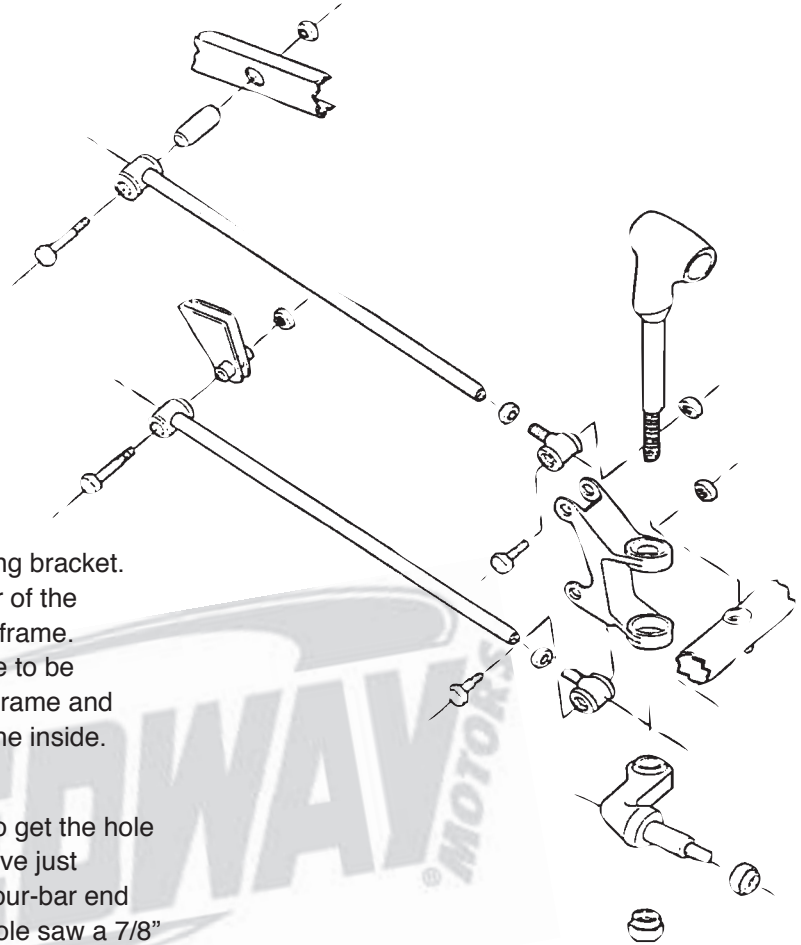

-NOTICE: MODEL "A" OWNERS

When installing your four bar system, you will follow the same basic steps, except your job will be a bit easier. Your frame brackets mount all four radius rods without any frame drilling.

NOTE: The weight of the car must be on wheels and not on a jack.

Speedway Motors Inc., P.O. Box 81906
Lincoln, NE 68501 (402) 323-3200
www.speedwaymotors.com



IMPORTANT

DISCLAIMER In an effort to offer our customers the low prices, quick service and great value, Speedway Motors reserves the right to change suppliers, specifications, colors, prices, materials. Each of the previous items is subject to change without notice. Speedway is not responsible for any typographical errors or misinterpretations. Quantities are limited on some items.

WARRANTY DISCLAIMER The purchaser understands and recognizes that racing parts, specialized street rod equipment, and all parts and services sold by Speedway Motors, Inc. are exposed to many and varied conditions due to the manner in which they are installed and used. Speedway Motors, Inc. makes no warranties, either express or implied, including any warranty of merchantability or fitness for a particular purpose other than those contained in its current catalog with respect to the goods identified on the face of the invoice. There is no warranty expressed or implied as to whether the goods sold hereby will protect purchaser or ultimate user of such goods from injury or death. Speedway Motors assumes no liability after this period.

DAMAGE CLAIMS Always inspect your package upon delivery. Inspect all packages in the presence of the delivery driver. The driver must note any damage. Ask the driver the Carrier's procedures for handling damage claims. You must hold the original box, packing material and damaged merchandise for inspection or the carrier will not honor the claim. Notify Speedway Motors customer service department for instructions on returning damaged goods. Speedway is not responsible if no notification is given within 5 days of receipt.

SHORTAGES Always check the contents of your delivery to insure all the parts that you ordered were received. Please read the invoice. Double check all packing materials, small items may be wrapped inside with these products. Shortages may occur from damage to the box, so save all packing materials. Inspect the box for holes that would allow parts to fall out. If you are missing any item(s) be sure to check your invoice for back orders or canceled items before calling the customer service department. If Speedway has to split a shipment into multiple boxes, packages may be delivered on different days. You need to contact the customer service department within 5 days of delivery to assure the prompt replacement. Speedway Motors assumes no liability after this period.

REFUSALS All refused COD customers will be billed a 15% restocking charge plus freight to and from the destination! If you have questions please contact Speedway's customer service department.

WARRANTY CLAIMS If an item has a manufacturer's warranty as being free from defects we will exchange only. If the item has been used and you are requesting warranty work, this may take up to 30 days as warranty work is done by the manufacturer NOT Speedway Motors. If you have any questions please contact customer service.

RETURNS Speedway wants you to be satisfied with your purchase. If within 30 days after you receive your shipment you are not satisfied, you may return the item for refund or exchange. All exchanged or returned merchandise must be in original factory condition with no modifications or alterations. Returned merchandise must include all packaging materials, warranty cards, manuals, and accessories. If the items being returned need to be repackaged there will be a re-packing charge. Re-pack the item in a sturdy box and include a copy of your invoice and complete the form on the back of the invoice. You must ship orders back **PRE-PAID. WE DO NOT ACCEPT COD SHIPMENTS.** All exchanges need to have reshipping charges included. Items that are returned after 30 days are subject to 15% restocking charges. All fiberglass returned will have 15% restocking charge. No returns on electrical parts, video tapes, and books. Absolutely no returns on special order or close out merchandise.

FREE CATALOGS Speedway Motors offers FREE catalogs for Race, Street, Sprint and Midget, Sport Compact and Pedal Car restoration.

**Some items are not legal for sale or use in California on pollution controlled motor vehicles. These items are legal in California for racing vehicles only which may never be used upon a highway.

Speedway Motors Inc., P.O. Box 81906
Lincoln, NE 68501 (402) 323-3200
www.speedwaymotors.com



©Speedway Motors, Inc. 2007