

INSTRUCTIONS

916-32004

INSTALLATION INSTRUCTIONS SAGINAW STEERING BOX INTO A 1941 TO 1948 FORD

- **Before you start, take inventory. You should have the following parts:**

- 1 - **GM Saginaw Steering Box**
- 1 - **'37 - '48 Ford**
- 1 - **Mounting Bracket (KIT)**
- 3 - **7/16" UNC X 1" Bolts (KIT)**
- 1 - **7/16" UNC X 1 1/4" Bolt (KIT)**
- 1 - **7/16" UNC X 1 1/2" Bolt (KIT)**
- 1 - **7/16" UNC X 1 3/4" Bolt (KIT)**
- 5 - **7/6" Lock Washers (KIT)**
- 2 - **7/16" UNC Nuts (KIT)**

- To begin the installation, it is suggested that the left side of the exhaust be removed. (Depending on the engine you have, you may need to change the exhaust routing). We recommend that you not purchase your exhaust system until after you have installed your steering box and have identified the clearance requirements.
- Remove the old Ford steering box and column.
- If the steering arm on the Saginaw Steering Box does not point forward, remove it, (you may have to heat it and use a puller). Set the arm aside for later installation.
- For the following instructions, refer to illustration. A slight modification of the Saginaw steering box is required. The tapped hole "D" must be drilled out to 1/2", and the cast gussets on the box must be filed down. A bolt will be installed through this hole and into the bracket at the tapped hole "D".
- Fasten the bracket to the frame by installing 1" bolts through hole "E" and "F". Assemble nuts and lockwashers inside the frame and tighten finger tight.
- Install the 1 1/4" bolt into the hole you drilled in the steering box at hole "D". Note that no lockwasher or nut is required.
- Position the box against the bracket and screw the bolt in hole "D" into the steering bracket. DO NOT tighten.
- Screw the 1 3/4" bolt through the frame and bracket into hole "C". DO NOT tighten.
- Screw a 1" bolt through the bracket into hole "A", using a lockwasher under the head of the bolt. DO NOT tighten.
- Screw the 1 1/2" bolt through bracket into the box at "B", using a lockwasher under the head of the bolt.
- Tighten the bolts at "A", "B", and "D".
- The box is now loosely attached to the frame. The steering column should now be installed to determine the final position of the steering box.
- Once the box has been located, tighten the bolts at "C", "E", and "F".
- Fasten the steering column to the steering box.
- Locate the steering arm that you removed, and slide it on the shaft pointing toward the front of the car. DO NOT tighten it yet, you may need to move it again.
- Turn the steering wheel all the way to the right. Note the position of the steering arm.
- Turn the steering wheel all the way to the left. Note the position of the steering arm.
- From the travel you noted, center the steering arm. It should be pointed toward the front of the car. If it is not, take it off and position it so that it is.
- Note the angle that the arm hangs down at, and look for any interferences when the drag link is attached. If necessary, remove the arm, heat it, and bend as needed.
- Tighten the nut that is holding the steering arm on the box.
- Install your drag link.

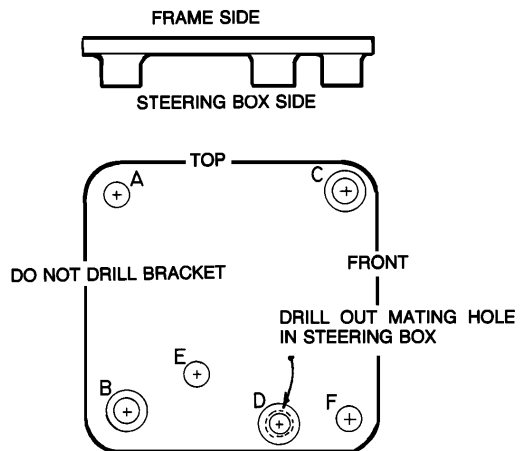

IMPORTANT

DISCLAIMER In an effort to offer our customers the low prices, quick service and great value, Speedway Motors reserves the right to change suppliers, specifications, colors, prices, materials. Each of the previous items is subject to change without notice. Speedway is not responsible for any typographical errors or misinterpretations. Quantities are limited on some items.

WARRANTY DISCLAIMER The purchaser understands and recognizes that racing parts, specialized street rod equipment, and all parts and services sold by Speedway Motors, Inc. are exposed to many and varied conditions due to the manner in which they are installed and used. Speedway Motors, Inc. makes no warranties, either express or implied, including any warranty of merchantability or fitness for a particular purpose other than those contained in its current catalog with respect to the goods identified on the face of the invoice. There is no warranty expressed or implied as to whether the goods sold hereby will protect purchaser or ultimate user of such goods from injury or death. Speedway Motors assumes no liability after this period.

DAMAGE CLAIMS Always inspect your package upon delivery. Inspect all packages in the presence of the delivery driver. The driver must note any damage. Ask the driver the Carrier's procedures for handling damage claims. You must hold the original box, packing material and damaged merchandise for inspection or the carrier will not honor the claim. Notify Speedway Motors customer service department for instructions on returning damaged goods. Speedway is not responsible if no notification is given within 5 days of receipt.

SHORTAGES Always check the contents of your delivery to insure all the parts that you ordered were received. Please read the invoice. Double check all packing materials, small items may be wrapped inside with these products. Shortages may occur from damage to the box, so save all packing materials. Inspect the box for holes that would allow parts to fall out. If you are missing any item(s) be sure to check your invoice for back orders or canceled items before calling the customer service department. If Speedway has to split a shipment into multiple boxes, packages may be delivered on different days. You need to contact the customer service department within 5 days of delivery to assure the prompt replacement. Speedway Motors assumes no liability after this period.

REFUSALS All refused COD customers will be billed a 15% restocking charge plus freight to and from the destination! If you have questions please contact Speedway's customer service department.

WARRANTY CLAIMS If an item has a manufacturer's warranty as being free from defects we will exchange only. If the item has been used and you are requesting warranty work, this may take up to 30 days as warranty work is done by the manufacturer NOT Speedway Motors. If you have any questions please contact customer service.

RETURNS Speedway wants you to be satisfied with your purchase. If within 30 days after you receive your shipment you are not satisfied, you may return the item for refund or exchange. All exchanged or returned merchandise must be in original factory condition with no modifications or alterations. Returned merchandise must include all packaging materials, warranty cards, manuals, and accessories. If the items being returned need to be repackaged there will be a re-packing charge. Re-pack the item in a sturdy box and include a copy of your invoice and complete the form on the back of the invoice. You must ship orders back **PRE-PAID. WE DO NOT ACCEPT COD SHIPMENTS.** All exchanges need to have reshipping charges included. Items that are returned after 30 days are subject to 15% restocking charges. All fiberglass returned will have 15% restocking charge. No returns on electrical parts, video tapes, and books. Absolutely no returns on special order or close out merchandise.

FREE CATALOGS Speedway Motors offers FREE catalogs for Race, Street, Sprint and Midget, Sport Compact and Pedal Car restoration.

**Some items are not legal for sale or use in California on pollution controlled motor vehicles. These items are legal in California for racing vehicles only which may never be used upon a highway.

Speedway Motors Inc., P.O. Box 81906
Lincoln, NE 68501 (402) 323-3200
www.speedwaymotors.com



©Speedway Motors, Inc. 2007