

INSTRUCTIONS

916-31931

©Speedway Motors, Inc. Dec, 2011

5 LUG DISC BRAKE KIT - FOR 1955-64 GM FULLSIZE CARS

PARTS LIST

Rotors: 910-65390	1969-'72 GM Midsize 11"	Outer Bearing	912-TLM11949
Calipers: 910-31045	1978+ GM Metric Calipers	Inner Bearing	912-TLM67048
		Inner Seal	912-S18543

NOTE: Before beginning installation, make sure your wheels fit on the disc rotor. Also, this kit works only with 15" and larger wheel, due to the 11" rotors.

NOTE: 5/8" I.D. spacer is for use on 1959-64 only. Discard this spacer for 1955-58 applications.

INSTRUCTIONS:

1. **Remove the drum and backing plate** assemblies so all that remains are the stock spindles. Inspect the bearing surfaces on the spindle. Use a piece of 180-grit emery cloth to remove any corrosion or other imperfections on the spindle.
2. **Install the caliper** mounting bracket and steering arms to the spindle. Install the 5/8" bolt through the bracket and into the threaded hole in the top of the spindle. (1959-1964 cars will use the larger spacer between the upper mounting boss on the spindle and the caliper bracket). The bracket is positioned so that the caliper mounts towards the rear of the car and the bends in the bracket mounts the caliper farther away from the rotor. The lower portion of the bracket will be located where the steering arm was bolted to the spindle. The rear of the steering arm will now be bolted to the bracket, and the front will be bolted to the spacer
3. **Pack the inner bearing** with grease and install it along with the seal.
4. **Slide rotor onto spindle.** Pack and install outer bearing and secure with spindle washer and spindle nut.
5. **Set the bearing preload.** Start by tightening the nut while rotating the rotor. Once the nut is good and tight, stop rotating the rotor and back the nut off 1 full turn. Now, hand-tighten the nut until it just starts to get tight. Back the nut off until the slots in the nut are aligned with the hole in the spindle. Install the cotter pin and dust cap.
6. **Install the caliper** with the bleeder on the top. Install brake hoses. Make sure everything is tight and proceed to bleed the system.

WARNING: Stock drum brake wheels may not work with disc brake conversions. Drum brake wheels were not made with disc brakes in mind so there may be wheel to caliper clearance problems. Before installing this kit, make sure your wheels fit the brake assembly.

For those wanting to keep stock wheels that interfere with the installation, there are companies such as, Stockton Wheel Co. and Wheel Vintiques that can remove the original wheel centers and re-install them into a new disc brake rim.

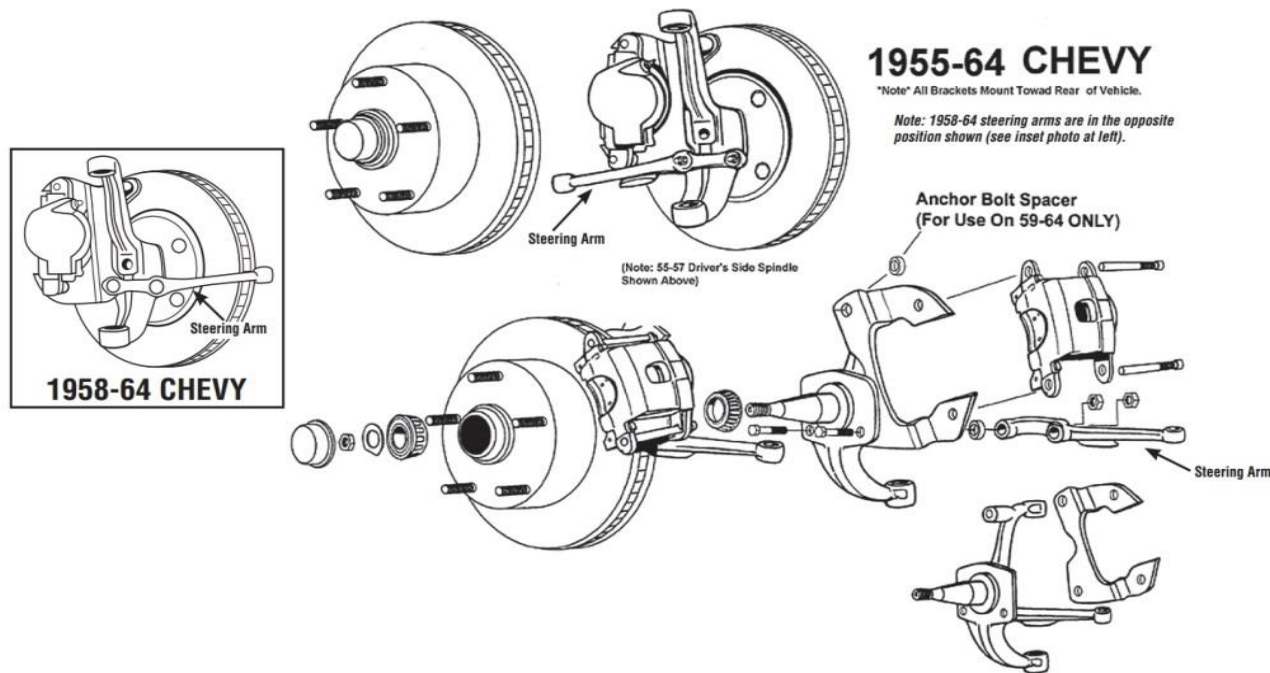

IMPORTANT

DISCLAIMER In an effort to offer our customers the low prices, quick service and great value, Speedway Motors reserves the right to change suppliers, specifications, colors, prices, materials. Each of the previous items is subject to change without notice. Speedway is not responsible for any typographical errors or misinterpretations. Quantities are limited on some items.

WARRANTY DISCLAIMER The purchaser understands and recognizes that racing parts, specialized street rod equipment, and all parts and services sold by Speedway Motors, Inc. are exposed to many and varied conditions due to the manner in which they are installed and used. Speedway Motors, Inc. makes no warranties, either express or implied, including any warranty of merchantability or fitness for a particular purpose other than those contained in its current catalog with respect to the goods identified on the face of the invoice. There is no warranty expressed or implied as to whether the goods sold hereby will protect purchaser or ultimate user of such goods from injury or death. Speedway Motors assumes no liability after this period.

DAMAGE CLAIMS Always inspect your package upon delivery. Inspect all packages in the presence of the delivery driver. The driver must note any damage. Ask the driver the Carrier's procedures for handling damage claims. You must hold the original box, packing material and damaged merchandise for inspection or the carrier will not honor the claim. Notify Speedway Motors customer service department for instructions on returning damaged goods. Speedway is not responsible if no notification is given within 5 days of receipt.

SHORTAGES Always check the contents of your delivery to insure all the parts that you ordered were received. Please read the invoice. Double check all packing materials, small items may be wrapped inside with these products. Shortages may occur from damage to the box, so save all packing materials. Inspect the box for holes that would allow parts to fall out. If you are missing any item(s) be sure to check your invoice for back orders or canceled items before calling the customer service department. If Speedway has to split a shipment into multiple boxes, packages may be delivered on different days. You need to contact the customer service department within 5 days of delivery to assure the prompt replacement. Speedway Motors assumes no liability after this period.

REFUSALS All refused COD customers will be billed a 15% restocking charge plus freight to and from the destination! If you have questions please contact Speedway's customer service department.

WARRANTY CLAIMS If an item has a manufacturer's warranty as being free from defects we will exchange only. If the item has been used and you are requesting warranty work, this may take up to 30 days as warranty work is done by the manufacturer NOT Speedway Motors. If you have any questions please contact customer service.

RETURNS Speedway wants you to be satisfied with your purchase. If within 30 days after you receive your shipment you are not satisfied, you may return the item for refund or exchange. All exchanged or returned merchandise must be in original factory condition with no modifications or alterations. Returned merchandise must include all packaging materials, warranty cards, manuals, and accessories. If the items being returned need to be repackaged there will be a re-packing charge. Re-pack the item in a sturdy box and include a copy of your invoice and complete the form on the back of the invoice. You must ship orders back **PRE-PAID. WE DO NOT ACCEPT COD SHIPMENTS.** All exchanges need to have reshipping charges included. Items that are returned after 30 days are subject to 15% restocking charges. All fiberglass returned will have 15% restocking charge. No returns on electrical parts, video tapes, and books. Absolutely no returns on special order or closeout merchandise.

FREE CATALOGS Speedway Motors offers FREE catalogs for Race, Street, Sprint and Midget, Sport Compact and Pedal Car restoration.

**Some items are not legal for sale or use in California on pollution controlled motor vehicles. These items are legal in California for racing vehicles only which may never be used upon a highway.



Speedway Motors Inc., P.O. Box 81906
Lincoln, NE 68501 (402) 323-3200
www.speedwaymotors.com