

INSTRUCTIONS

910-31943
COMPLETE KIT

916-31913
BRACKET KIT ONLY

©Speedway Motors, Inc. March 2007

11" BRAKE KIT FOR MUSTANG II SPINDLE (GM ROTOR)

**PLEASE READ INSTRUCTIONS COMPLETELY
BEFORE STARTING YOUR INSTALLATION!**

Quickly and easily install '69-'72 GM intermediate rotors and calipers on your '74-'78 Mustang II or '74-'80 Pinto/Bobcat spindles.

Parts List

| Index No. | Description | Part Number | Quantity |
|----------------------------|--|--------------------|----------|
| 1* | Caliper bracket-L | 916-31913-1-L | 1 |
| 1* | Caliper bracket-R | 916-31913-1-R | 1 |
| * | Hardware kit | 916-361313-2 | 1 |
| 2 | 1/2"-13x2 1/4" GR 8 bolts | In hardware kit | 2 |
| 3 | 1/2" lock washers | In hardware kit | 2 |
| 4 | 7/16" -14x1 1/4" GR 8 bolts | In hardware kit | 2 |
| 5 | 7/16" lock washers | In hardware kit | 2 |
| 6* | Seal | 912-S19215 | 2 |
| 7 | Inner bearing cone | 912-TL68149 | 2 |
| 8 | Inner bearing cup | 912-TL68110 | 2 |
| 9 | '69-'72 GM 11" rotors 5 on 4 3/4" BC | 910-65390 | 2 |
| 10 | Outer bearing cup | 912-TLM12710 | 2 |
| 11 | Outer bearing cone | 912-TLM12749 | 2 |
| 12 | Spindle nut/washer | 916-31936 | 2 |
| 13 | Cotter pin | In spindle nut kit | 2 |
| 14** | Dust cap (pr) | 910-31071 | 1 |
| 15 | '69-'72 GM intermediate left caliper | 910-31035-L | 1 |
| 15 | '69-'72 GM intermediate left caliper | 910-31035-R | 1 |
| 16 | Brake pad (set) | 919-3382 | 1 |
| 17 | Caliper bolts | 835-2300542 | 4 |
| 18** | Spindle (pr) | 910-34307 | 1 |
| * bracket kit parts only | | | |
| ** not included | | | |
| Other Parts needed: | | | |
| | 16" Stainless steel brake line kit (7/16-20 thread for Speedway calipers) | 617-8562 | 1 |

BRAKE INSTALLATION ALERT: The selection and installation of brake components should only be done by personnel experienced in the proper installation and operation of braking systems. The installer must use his/her own discretion to determine the suitability of the brake components and brake kits for every particular application.

Speedway Motors, Inc. makes no warranties, either expressed or implied, including any warranty of merchantability or fitness for a particular purpose, other than those contained in its current catalog or website with respect to the goods identified on the face of the invoice. There is no warranty expressed or implied as to whether the goods sold hereby will protect the purchaser or ultimate user of such goods from injury or death.

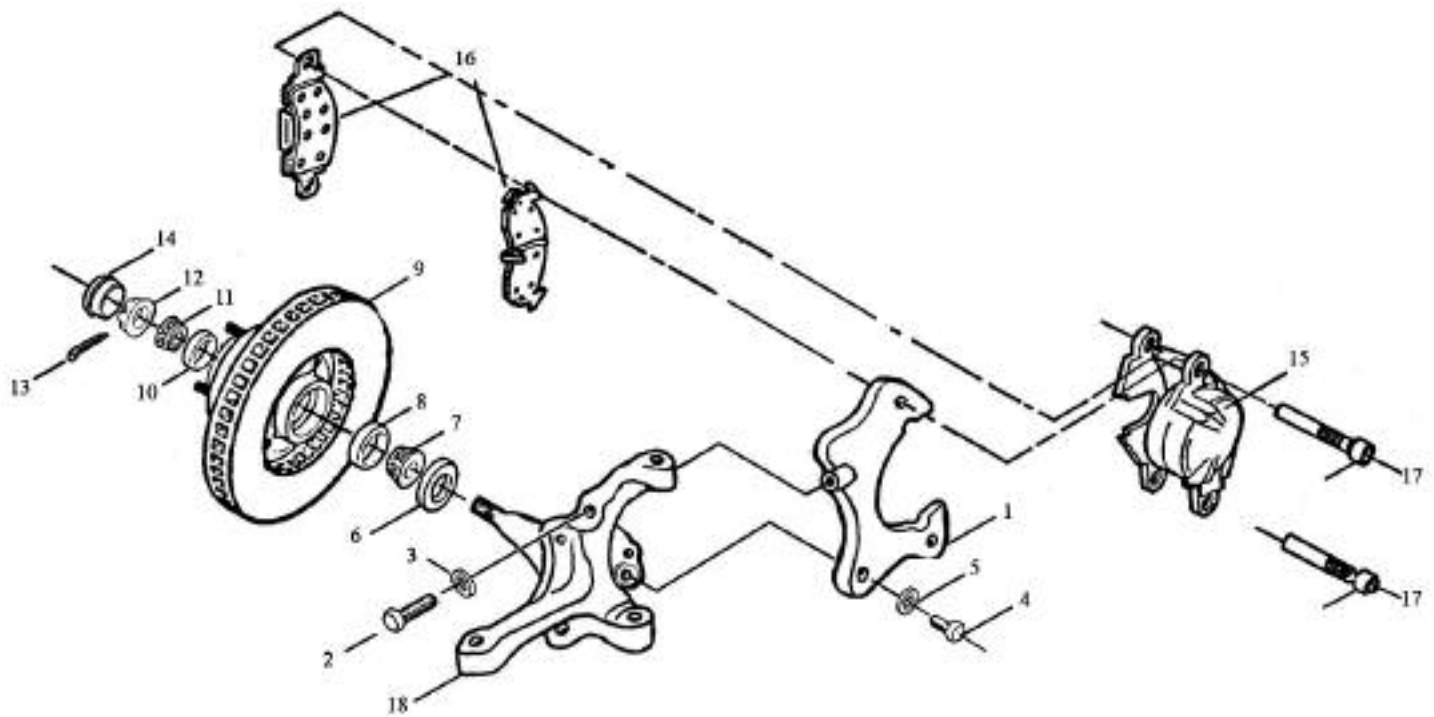

1. Using the parts list supplied, double check that you received all the parts in this kit. If there are any missing parts, please contact the customer service department.
2. Remove the stock GM inner and outer races from your rotor. Replace them with the Ford races (#8) and (#10) supplied. **NOTE:** Do not attempt to install the new Ford bearings with the GM races in your rotor. The races in your rotor must be replaced with the Ford races supplied.
3. Pack and install the inner bearing (#7) with fresh disc brake bearing grease, and install the grease seal (#6). Seals must be installed straight. A seal installation tool works well for this. **NOTE:** This is a special made seal for this application. You will not be able to purchase one at an auto parts store. If one gets damaged in installation please order under Speedway part number 912-S19215.
4. Install the rotor (#9) on to the spindle (#18). Pack the outer bearing (#11) and install in the rotor, followed by the special washer/spindle nut (#12) supplied. Adjust the bearing preload as normal. Install the cotter pin (#13) and dust cap (#14). **NOTE:** The rotors on some brake kits may interfere with the end of the stock control arm. You can modify the end of the control arm for clearance by grinding or bending the outer lip over with a hammer.
5. Install the caliper bracket (#1) on to the spindle (#18). Thread the upper bolt (#2) (1/2-13x2^{1/4} GR 8) through the spindle and into the caliper bracket and leave hand tight. Thread the lower bolt (#4) (7/16-14 x 1^{1/4} GR 8) through the bracket and into the spindle. The caliper bracket should be parallel to the rotor. If it is not, switch the left and right brackets. Once you determine you have the correct bracket, tighten both bolts making sure you use thread locker on the threads. Torque the 1/2" upper bolt to 38-57 ft. lbs. and the 7/16" lower bolt to 25-37 ft. lbs.
6. Install the calipers (#15) on to the mounting brackets with the bleeders pointing up. Only use the correct GM mounting bolts (#17).
7. Install new brake lines making sure you check that the lines have clearance through the entire suspension travel and turning radius. Bleed the system as normal.
8. Before operating the vehicle, test the brakes under controlled conditions. Make several stops in a safe area from low speeds and gradually work up to operating speeds.

IMPORTANT

DISCLAIMER In an effort to offer our customers the low prices, quick service and great value, Speedway Motors reserves the right to change suppliers, specifications, colors, prices, materials. Each of the previous items is subject to change without notice. Speedway is not responsible for any typographical errors or misinterpretations. Quantities are limited on some items.

WARRANTY DISCLAIMER The purchaser understands and recognizes that racing parts, specialized street rod equipment, and all parts and services sold by Speedway Motors, Inc. are exposed to many and varied conditions due to the manner in which they are installed and used. Speedway Motors, Inc. makes no warranties, either express or implied, including any warranty of merchantability or fitness for a particular purpose other than those contained in its current catalog with respect to the goods identified on the face of the invoice. There is no warranty expressed or implied as to whether the goods sold hereby will protect purchaser or ultimate user of such goods from injury or death. Speedway Motors assumes no liability after this period.

DAMAGE CLAIMS Always inspect your package upon delivery. Inspect all packages in the presence of the delivery driver. The driver must note any damage. Ask the driver the Carrier's procedures for handling damage claims. You must hold the original box, packing material and damaged merchandise for inspection or the carrier will not honor the claim. Notify Speedway Motors customer service department for instructions on returning damaged goods. Speedway is not responsible if no notification is given within 5 days of receipt.

SHORTAGES Always check the contents of your delivery to insure all the parts that you ordered were received. Please read the invoice. Double check all packing materials, small items may be wrapped inside with these products. Shortages may occur from damage to the box, so save all packing materials. Inspect the box for holes that would allow parts to fall out. If you are missing any item(s) be sure to check your invoice for back orders or canceled items before calling the customer service department. If Speedway has to split a shipment into multiple boxes, packages may be delivered on different days. You need to contact the customer service department within 5 days of delivery to assure the prompt replacement. Speedway Motors assumes no liability after this period.

REFUSALS All refused COD customers will be billed a 15% restocking charge plus freight to and from the destination! If you have questions please contact Speedway's customer service department.

WARRANTY CLAIMS If an item has a manufacturer's warranty as being free from defects we will exchange only. If the item has been used and you are requesting warranty work, this may take up to 30 days as warranty work is done by the manufacturer NOT Speedway Motors. If you have any questions please contact customer service.

RETURNS Speedway wants you to be satisfied with your purchase. If within 30 days after you receive your shipment you are not satisfied, you may return the item for refund or exchange. All exchanged or returned merchandise must be in original factory condition with no modifications or alterations. Returned merchandise must include all packaging materials, warranty cards, manuals, and accessories. If the items being returned need to be repackaged there will be a re-packing charge. Re-pack the item in a sturdy box and include a copy of your invoice and complete the form on the back of the invoice. You must ship orders back **PRE-PAID. WE DO NOT ACCEPT COD SHIPMENTS.** All exchanges need to have reshipping charges included. Items that are returned after 30 days are subject to 15% restocking charges. All fiberglass returned will have 15% restocking charge. No returns on electrical parts, video tapes, and books. Absolutely no returns on special order or close out merchandise.

FREE CATALOGS Speedway Motors offers FREE catalogs for Race, Street, Sprint and Midget, Sport Compact and Pedal Car restoration.

**Some items are not legal for sale or use in California on pollution controlled motor vehicles. These items are legal in California for racing vehicles only which may never be used upon a highway.

Speedway Motors Inc., P.O. Box 81906
Lincoln, NE 68501 (402) 323-3200
www.speedwaymotors.com



©Speedway Motors, Inc. 2007