

# INSTRUCTIONS

910-70027

## UNIVERSAL SEAT MOUNT

**NOTE:** This universal seat mounting system is designed to work with wide variety of vehicle applications. As such, these instructions are not intended to be all inclusive. Since every application is different, some modification of some components may be required.

1. Remove protective plastic caps from slider studs.
2. Install primary slider (the one with the adjustment lever) by inserting mount studs into tabs on mount frame. Secure with lock nuts.

**NOTE:** The primary slider must be mounted on the right hand side of mount frame, with the adjustment lever facing forward and the locking mechanism facing the center of the mounting frame, regardless of whether the seat is being installed on the passengers or drivers side of vehicle.

3. Install secondary slider on left side of mount frame with the locking mechanism facing the center of the mount frame. Secure with lock nuts.
4. Release locking mechanism and move slider aft to expose the square bolt hole. Insert carriage bolt up through slider and seat mounting plate, start nut hand tight only.
5. Release locking mechanism and move slider forward to expose the square bolt hole. Insert carriage bolt up through slider and seat mounting plate, start nut hand tight only.
6. Repeat steps 4 and 5 on remaining slider and tighten all nuts.

**NOTE:** Some applications may require spacers (included) between the slider and mount plates. Some applications may require the flange of the mount plates up, others with the mount flange down. Use the combination that works best for your application.

7. Center both sliders and install pull wire between the two sliders. Connect one end of pull release wire into the farthest aft hole on the secondary slider locking mechanism. Connect the other end of pull wire into the rear hole on adjustment lever (check illustration).

Step #7

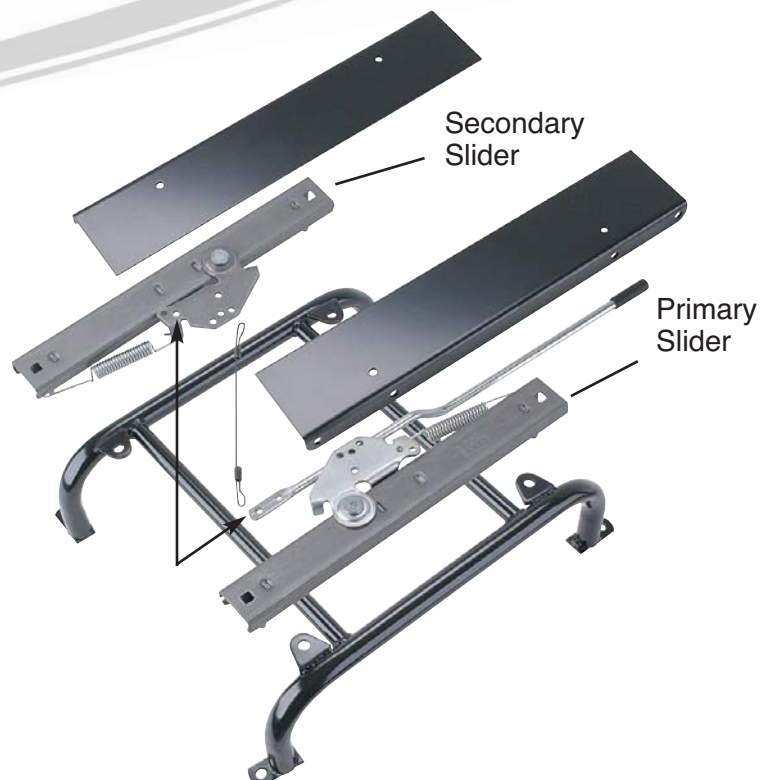

# IMPORTANT

**DISCLAIMER** In an effort to offer our customers the low prices, quick service and great value, Speedway Motors reserves the right to change suppliers, specifications, colors, prices, materials. Each of the previous items is subject to change without notice. Speedway is not responsible for any typographical errors or misinterpretations. Quantities are limited on some items.

**WARRANTY DISCLAIMER** The purchaser understands and recognizes that racing parts, specialized street rod equipment, and all parts and services sold by Speedway Motors, Inc. are exposed to many and varied conditions due to the manner in which they are installed and used. Speedway Motors, Inc. makes no warranties, either express or implied, including any warranty of merchantability or fitness for a particular purpose other than those contained in its current catalog with respect to the goods identified on the face of the invoice. There is no warranty expressed or implied as to whether the goods sold hereby will protect purchaser or ultimate user of such goods from injury or death. Speedway Motors assumes no liability after this period.

**DAMAGE CLAIMS** Always inspect your package upon delivery. Inspect all packages in the presence of the delivery driver. The driver must note any damage. Ask the driver the Carrier's procedures for handling damage claims. You must hold the original box, packing material and damaged merchandise for inspection or the carrier will not honor the claim. Notify Speedway Motors customer service department for instructions on returning damaged goods. Speedway is not responsible if no notification is given within 5 days of receipt.

**SHORTAGES** Always check the contents of your delivery to insure all the parts that you ordered were received. Please read the invoice. Double check all packing materials, small items may be wrapped inside with these products. Shortages may occur from damage to the box, so save all packing materials. Inspect the box for holes that would allow parts to fall out. If you are missing any item(s) be sure to check your invoice for back orders or canceled items before calling the customer service department. If Speedway has to split a shipment into multiple boxes, packages may be delivered on different days. You need to contact the customer service department within 5 days of delivery to assure the prompt replacement. Speedway Motors assumes no liability after this period.

**REFUSALS** All refused COD customers will be billed a 15% restocking charge plus freight to and from the destination! If you have questions please contact Speedway's customer service department.

**WARRANTY CLAIMS** If an item has a manufacturer's warranty as being free from defects we will exchange only. If the item has been used and you are requesting warranty work, this may take up to 30 days as warranty work is done by the manufacturer NOT Speedway Motors. If you have any questions please contact customer service.

**RETURNS** Speedway wants you to be satisfied with your purchase. If within 30 days after you receive your shipment you are not satisfied, you may return the item for refund or exchange. All exchanged or returned merchandise must be in original factory condition with no modifications or alterations. Returned merchandise must include all packaging materials, warranty cards, manuals, and accessories. If the items being returned need to be repackaged there will be a re-packing charge. Re-pack the item in a sturdy box and include a copy of your invoice and complete the form on the back of the invoice. You must ship orders back **PRE-PAID. WE DO NOT ACCEPT COD SHIPMENTS.** All exchanges need to have reshipping charges included. Items that are returned after 30 days are subject to 15% restocking charges. All fiberglass returned will have 15% restocking charge. No returns on electrical parts, video tapes, and books. Absolutely no returns on special order or close out merchandise.

**FREE CATALOGS** Speedway Motors offers FREE catalogs for Race, Street, Sprint and Midget, Sport Compact and Pedal Car restoration.

\*\*Some items are not legal for sale or use in California on pollution controlled motor vehicles. These items are legal in California for racing vehicles only which may never be used upon a highway.

Speedway Motors Inc., P.O. Box 81906  
Lincoln, NE 68501 (402) 323-3200  
[www.speedwaymotors.com](http://www.speedwaymotors.com)



©Speedway Motors, Inc. 2007