

INSTRUCTIONS

910-34327

©Speedway Motors, Inc Dec. 2008.

MUSTANG II TUBULAR LOWER CONTROL ARMS FOR STOCK SPRINGS

PLEASE READ INSTRUCTIONS COMPLETELY BEFORE STARTING YOUR INSTALLATION

This kit installs the tubular lower control arms for stock springs on to the Mustang II suspension crossmember.

PARTS LIST

Index Number	Description	Qty.
1	Tubular lower arm (left)	1
1	Tubular lower arm (right)	1
2	Screw in ball joint	2
3	Ball joint boot	2
4	9/16"-18 castle nut	2
5	Cotter pin	2
6	Grease fitting	2
7	Ball joint spacer washers (2)	2
8	7/16"-14 x 7" GR 5 hex bolts	2

Using the parts list above, double check that you have received all the parts in your kit. If there are any missing parts please contact our customer service department.

1. Thread the ball joints (#2) into the lower control arms (#1) and tighten. If the ball joint is a little tight going in you can use a little anti-seize on the threads.

2. Slide the lower control arms onto the crossmember and install the 1/2" lower control arm bolts and nuts. Raise the lower control arm to a horizontal position and tighten the bolts. Attach the strut rods to the control arms and torque the two 7/16" nuts to 25-37 ft. lbs. Pull the control arm down and install the spring onto the spring pocket, with the flat side of the spring pointing up. Place a floor jack under the ball joints and raise the control arms guiding the spring into the upper spring pocket. NOTE if you are installing these on a bare chassis you will need a spring compressor to install the springs.

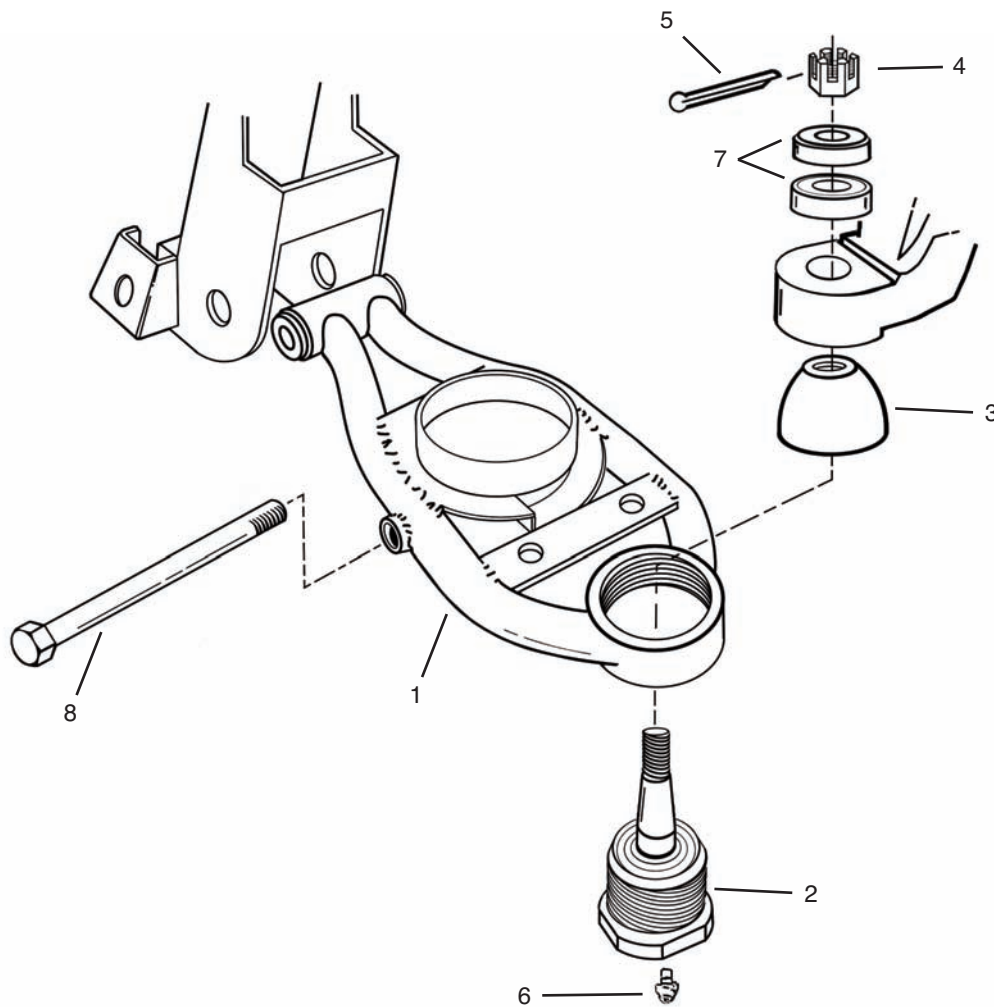

Fully extend the shock and slide it through the lower control arm guiding it into the upper shock mount. Install the 7/16"-14 x 7" lower shock bolts (#8) and torque to 25-37 ft. lbs. Secure the shock into the upper shock mount. Slide the ball joint boot (#3) over the lower ball joint and install the spindle. Install two ball joint spacers (#7) onto the lower ball joint followed by the castle nut (#4). Raise the lower control arm up and install the upper ball joint into the spindle and install the castle nut. Torque the castle nuts to 53-81 ft. lbs. continue to tighten until the slot and hole are aligned and install the cotter pin.

3. Once the car is back on the ground loosen the 1/2" inner pivot bolts and bounce the suspension to release the stress in the bushings, retighten and torque to 38-57 ft. lbs. New springs will usually settle 3/4"-1" over the first 300-500 miles. After the springs settle the lower control arms should be level with all the weight on the car.



Speedway Motors Inc., P.O. Box 81906
 Lincoln, NE 68501 (402) 323-3200
www.speedwaymotors.com

IMPORTANT

DISCLAIMER In an effort to offer our customers the low prices, quick service and great value, Speedway Motors reserves the right to change suppliers, specifications, colors, prices, materials. Each of the previous items is subject to change without notice. Speedway is not responsible for any typographical errors or misinterpretations. Quantities are limited on some items.

WARRANTY DISCLAIMER The purchaser understands and recognizes that racing parts, specialized street rod equipment, and all parts and services sold by Speedway Motors, Inc. are exposed to many and varied conditions due to the manner in which they are installed and used. Speedway Motors, Inc. makes no warranties, either express or implied, including any warranty of merchantability or fitness for a particular purpose other than those contained in its current catalog with respect to the goods identified on the face of the invoice. There is no warranty expressed or implied as to whether the goods sold hereby will protect purchaser or ultimate user of such goods from injury or death. Speedway Motors assumes no liability after this period.

DAMAGE CLAIMS Always inspect your package upon delivery. Inspect all packages in the presence of the delivery driver. The driver must note any damage. Ask the driver the Carrier's procedures for handling damage claims. You must hold the original box, packing material and damaged merchandise for inspection or the carrier will not honor the claim. Notify Speedway Motors customer service department for instructions on returning damaged goods. Speedway is not responsible if no notification is given within 5 days of receipt.

SHORTAGES Always check the contents of your delivery to insure all the parts that you ordered were received. Please read the invoice. Double check all packing materials, small items may be wrapped inside with these products. Shortages may occur from damage to the box, so save all packing materials. Inspect the box for holes that would allow parts to fall out. If you are missing any item(s) be sure to check your invoice for back orders or canceled items before calling the customer service department. If Speedway has to split a shipment into multiple boxes, packages may be delivered on different days. You need to contact the customer service department within 5 days of delivery to assure the prompt replacement. Speedway Motors assumes no liability after this period.

REFUSALS All refused COD customers will be billed a 15% restocking charge plus freight to and from the destination! If you have questions please contact Speedway's customer service department.

WARRANTY CLAIMS If an item has a manufacturer's warranty as being free from defects we will exchange only. If the item has been used and you are requesting warranty work, this may take up to 30 days as warranty work is done by the manufacturer NOT Speedway Motors. If you have any questions please contact customer service.

RETURNS Speedway wants you to be satisfied with your purchase. If within 30 days after you receive your shipment you are not satisfied, you may return the item for refund or exchange. All exchanged or returned merchandise must be in original factory condition with no modifications or alterations. Returned merchandise must include all packaging materials, warranty cards, manuals, and accessories. If the items being returned need to be repackaged there will be a re-packing charge. Re-pack the item in a sturdy box and include a copy of your invoice and complete the form on the back of the invoice. You must ship orders back **PRE-PAID. WE DO NOT ACCEPT COD SHIPMENTS.** All exchanges need to have reshipping charges included. Items that are returned after 30 days are subject to 15% restocking charges. All fiberglass returned will have 15% restocking charge. No returns on electrical parts, video tapes, and books. Absolutely no returns on special order or close out merchandise.

FREE CATALOGS Speedway Motors offers FREE catalogs for Race, Street, Sprint and Midget, Sport Compact and Pedal Car restoration.

**Some items are not legal for sale or use in California on pollution controlled motor vehicles. These items are legal in California for racing vehicles only which may never be used upon a highway.

Speedway Motors Inc., P.O. Box 81906
Lincoln, NE 68501 (402) 323-3200
www.speedwaymotors.com



©Speedway Motors, Inc. 2006