

# INSTRUCTIONS

910-34322

## TUBULAR STRUT ROD KIT

**PLEASE READ INSTRUCTIONS COMPLETELY  
BEFORE STARTING YOUR INSTALLATION**

This kit will install tubular strut rods on 1974-78 Mustang II or 1974-80 Pinto/Bobcat aftermarket front suspension kits.

**NOTE:** A qualified welder should do all the welding using proper techniques.

1. Clamp a 2x4-inch board to the bottom of the crossmember, making sure it is long enough to support the control arms in a horizontal position. Install the lower control arms on the crossmember and attach the strut rods to the arms. Install the 7/16-20 x 1½" studs and nuts and tighten. The strut rods should angle toward the rear of the vehicle. The bushing ends of the strut rods should measure the same distance from the bottom of the frame on both sides. If they don't, average the dimensions and flex the bushing ends up or down to position them accordingly.
2. Make a cardboard template of the strut rod mounting brackets. With the control arms and strut rods supported in the horizontal positions, trim the cardboard templates so they line up with the strut rod bushings and the bottom and inside edges of your frame rails. Trim your brackets to fit your templates. The front and rear brackets will be slightly different. Install the 5/8" bolts through the brackets and the strut rod bushings, securing with 5/8" nylock nuts. Tighten nuts to fully seated position. Tack weld the strut rod brackets to the bottom and inside of the frame rails.
3. Tack weld the gussets between the front strut rod brackets and the bottom of your frame rail - the gussets angle toward the front of the vehicle. Remove the tubular strut rods and final weld the strut rod brackets and gussets in place.

After the suspension is re-assembled and back on the ground you can do the alignment. The wheel alignment should be done by a qualified alignment shop.

### **ALIGNMENT SPECIFICATIONS:**

CAMBER	1/2 Degree positive
CASTER	1 Degree positive (manual steering)
CASTER	3 Degrees positive (power steering)
TOE IN	1/8" plus or minus 1/8"

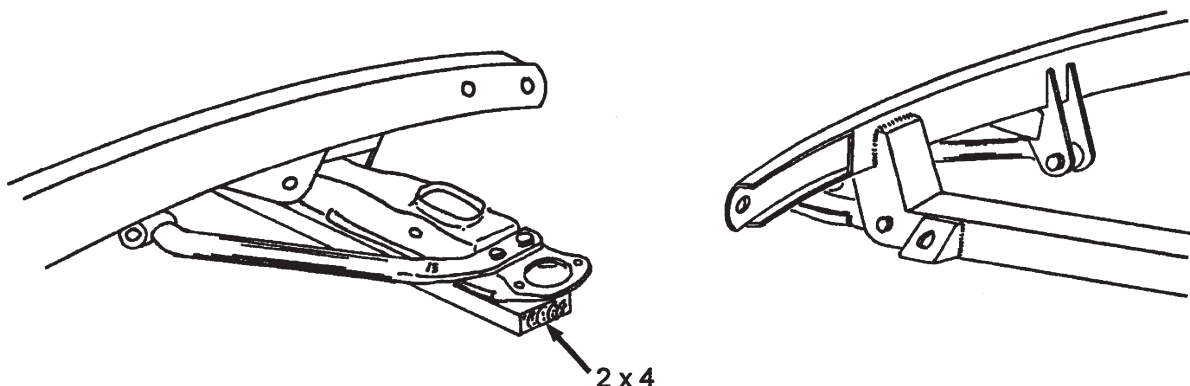

# IMPORTANT

**DISCLAIMER** In an effort to offer our customers the low prices, quick service and great value, Speedway Motors reserves the right to change suppliers, specifications, colors, prices, materials. Each of the previous items is subject to change without notice. Speedway is not responsible for any typographical errors or misinterpretations. Quantities are limited on some items.

**WARRANTY DISCLAIMER** The purchaser understands and recognizes that racing parts, specialized street rod equipment, and all parts and services sold by Speedway Motors, Inc. are exposed to many and varied conditions due to the manner in which they are installed and used. Speedway Motors, Inc. makes no warranties, either express or implied, including any warranty of merchantability or fitness for a particular purpose other than those contained in its current catalog with respect to the goods identified on the face of the invoice. There is no warranty expressed or implied as to whether the goods sold hereby will protect purchaser or ultimate user of such goods from injury or death. Speedway Motors assumes no liability after this period.

**DAMAGE CLAIMS** Always inspect your package upon delivery. Inspect all packages in the presence of the delivery driver. The driver must note any damage. Ask the driver the Carrier's procedures for handling damage claims. You must hold the original box, packing material and damaged merchandise for inspection or the carrier will not honor the claim. Notify Speedway Motors customer service department for instructions on returning damaged goods. Speedway is not responsible if no notification is given within 5 days of receipt.

**SHORTAGES** Always check the contents of your delivery to insure all the parts that you ordered were received. Please read the invoice. Double check all packing materials, small items may be wrapped inside with these products. Shortages may occur from damage to the box, so save all packing materials. Inspect the box for holes that would allow parts to fall out. If you are missing any item(s) be sure to check your invoice for back orders or canceled items before calling the customer service department. If Speedway has to split a shipment into multiple boxes, packages may be delivered on different days. You need to contact the customer service department within 5 days of delivery to assure the prompt replacement. Speedway Motors assumes no liability after this period.

**REFUSALS** All refused COD customers will be billed a 15% restocking charge plus freight to and from the destination! If you have questions please contact Speedway's customer service department.

**WARRANTY CLAIMS** If an item has a manufacturer's warranty as being free from defects we will exchange only. If the item has been used and you are requesting warranty work, this may take up to 30 days as warranty work is done by the manufacturer NOT Speedway Motors. If you have any questions please contact customer service.

**RETURNS** Speedway wants you to be satisfied with your purchase. If within 30 days after you receive your shipment you are not satisfied, you may return the item for refund or exchange. All exchanged or returned merchandise must be in original factory condition with no modifications or alterations. Returned merchandise must include all packaging materials, warranty cards, manuals, and accessories. If the items being returned need to be repackaged there will be a re-packing charge. Re-pack the item in a sturdy box and include a copy of your invoice and complete the form on the back of the invoice. You must ship orders back **PRE-PAID. WE DO NOT ACCEPT COD SHIPMENTS.** All exchanges need to have reshipping charges included. Items that are returned after 30 days are subject to 15% restocking charges. All fiberglass returned will have 15% restocking charge. No returns on electrical parts, video tapes, and books. Absolutely no returns on special order or close out merchandise.

**FREE CATALOGS** Speedway Motors offers FREE catalogs for Race, Street, Sprint and Midget, Sport Compact and Pedal Car restoration.

\*\*Some items are not legal for sale or use in California on pollution controlled motor vehicles. These items are legal in California for racing vehicles only which may never be used upon a highway.

Speedway Motors Inc., P.O. Box 81906  
Lincoln, NE 68501 (402) 323-3200  
[www.speedwaymotors.com](http://www.speedwaymotors.com)



©Speedway Motors, Inc. 2007