

INSTRUCTIONS

SPEEDWAY DELUXE KINGPIN SET

910-32115

'37-'41 FORD

910-32116

'42-'48 FORD

©Speedway Motors, Inc., October, 2008

1. Remove brake assembly and disassemble front end as required to allow removal of the old kingpin. With kingpin removed, separate the spindle from the axle. Using a suitable drift, remove the old kingpin bushings from spindle. Clean and inspect the spindle and axle bore to assure that they are free of nicks, burrs, or gouges. Using a stone or fine emery cloth, remove any burrs or sharp edges which could damage to the new bearings, being careful not to elongate or oversize the bores.

NOTE: If you are working with all new parts instead of a complete vehicle with conventional kingpins already installed, skip the disassembly step above.
2. **NOTE:** On the 1937-1941 Ford deluxe king pin kit 910-32115, there are two different size bearings in the kit (see illustration). The short bearings go inside (closest to the axle boss) and the long bearings go into the outside of the spindle (directly under the grease caps). On the 1942-1948 Ford deluxe king pin kit 910-32116, the bearings are all the same height.
3. Start by pressing one of the short bearings into the lower spindle boss. Using the supplied installation tool, drive it in until it is flush with the inside edge of the spindle casting. Next, press one of the long bearings into the lower spindle boss until it is flush with the *outside edge* of the spindle casting. Use caution, the alignment of the needle bearings is critical and the bearings can be damaged if installed cocked. With both bearings installed there should be a small gap between them. This gap is necessary so that grease can reach both bearings.
4. Place the thrust bearing onto the lower spindle boss with the lettered side of the bearing facing up.
CAUTION: The lock notch machined into the kingpin is not centered. The longer end of the pin must be installed down so that the notch lines up correctly with the lock pin hole in the axle boss. Apply a thin coat of grease to the kingpin prior to installation.
5. Position the spindle and bearing on the axle boss and carefully insert the long end of the kingpin from the top down through the axle boss, thrust bearing, and into the needle bearings in the lower boss of the spindle.
6. Check spindle for excessive end play. While maintaining upward pressure on the spindle insert a feeler gage between the top of the axle boss and the bottom side of the upper spindle boss. If the clearance exceeds .006", remove kingpin and install one or two of the included shims as required. Carefully reinstall kingpin making sure the shim is properly located and recheck end play.
7. Rotate the kingpin so the lock notch is aligned with the lock pin hole in the axle boss. Insert the threaded end of the lock pin into the front of the axle boss, making sure it engages the lock pin notch in the kingpin. Install the washer and nut on the lock pin on the aft side of the axle, leave finger tight at this time.

8. Support the spindle with a floor jack or blocks of wood and install one of the short bearings into the upper spindle boss using the installation tool. Drive the bearing all the way down until it contacts the top of the axle boss. Next, install one of the long bearings, drive it in until the top of the bearing is flush with the top of the spindle boss.
9. Move the spindle back and forth to make sure that it rotates freely and no excessive play is noted. Torque the nut on the lock pin to 55-65 ft lbs.
10. The new kingpins will be greased through the end caps, so you can remove the stock grease zerk and install the supplied set screws to seal the holes. The set screws should be installed until flush with the spindle casting, do not over tighten or the set screw will bottom out on the bearing and deform it. Use a drop of lockite on the threads to make sure they do not back out.

NOTE: Due to the wide variety of stock and aftermarket spindles on the market this kit includes two different styles of end caps. Four large diameter and two smaller diameter. A large diameter end cap and felt seal washer will always go on top of both kingpins, the correct lower cap will depend on which type of spindle is used.

11. Select one of the large end caps and position it on the top end of the kingpin with the lip of the end cap facing down toward the spindle; using the grease zerk to hold it in place. Tighten the zerk slowly. If the end cap contacts the top of the spindle boss before the zerk gets tight, unscrew zerk and remove cap. Install one of the small 1/4" I.D. shims on top of the kingpin and re-install the cap. Again, tighten slowly and check for proper clearance between the end cap and the top of the spindle, there should be a minimum of .010". If clearance is insufficient, remove cap and install a second shim. Recheck clearance. When clearance is correct, remove end cap and shims, install one of the felt seal washers in the recessed lip of the cap, and reinstall the cap and shims. Secure with the grease zerk.

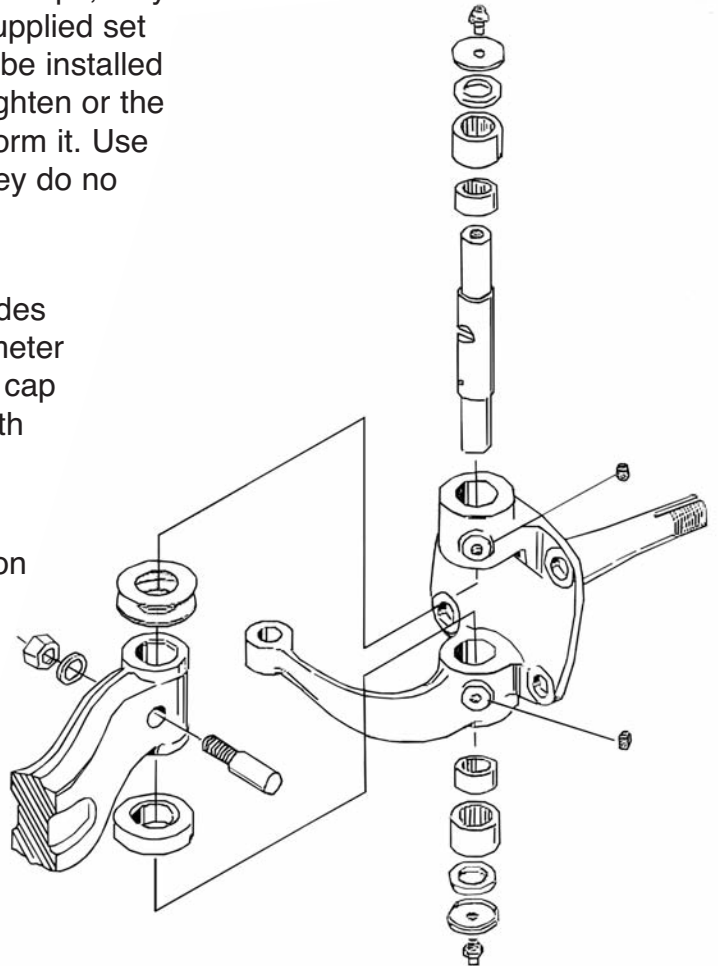

12. To install the lower end caps and seals, first identify the type of spindle that you are using. If you have the type of spindle in which the upper surface of the top spindle boss and the lower surface of the bottom spindle boss are machined parallel to each other, follow step 11 above to install one of the large-diameter end caps and felt seal washers. If you are using OEM spindles with integral steering arms or one of the aftermarket spindles with a rounded lower boss, you must use the small-diameter cap and O-ring. Install the O-ring over the end of kingpin. Install small diameter cap with lip facing up into the lower boss of the spindle, secure with grease zerk. Again, tighten zerk slowly. If cap bottoms out or binds up before the zerk is tight, remove and install one of the small shims. Reinstall lower cap and secure with grease zerk.
13. Use grease gun and grease each end of the kingpin. Reassemble front suspension, and double check steering for smooth operation.

IMPORTANT

DISCLAIMER In an effort to offer our customers the low prices, quick service and great value, Speedway Motors reserves the right to change suppliers, specifications, colors, prices, materials. Each of the previous items is subject to change without notice. Speedway is not responsible for any typographical errors or misinterpretations. Quantities are limited on some items.

WARRANTY DISCLAIMER The purchaser understands and recognizes that racing parts, specialized street rod equipment, and all parts and services sold by Speedway Motors, Inc. are exposed to many and varied conditions due to the manner in which they are installed and used. Speedway Motors, Inc. makes no warranties, either express or implied, including any warranty of merchantability or fitness for a particular purpose other than those contained in its current catalog with respect to the goods identified on the face of the invoice. There is no warranty expressed or implied as to whether the goods sold hereby will protect purchaser or ultimate user of such goods from injury or death. Speedway Motors assumes no liability after this period.

DAMAGE CLAIMS Always inspect your package upon delivery. Inspect all packages in the presence of the delivery driver. The driver must note any damage. Ask the driver the Carrier's procedures for handling damage claims. You must hold the original box, packing material and damaged merchandise for inspection or the carrier will not honor the claim. Notify Speedway Motors customer service department for instructions on returning damaged goods. Speedway is not responsible if no notification is given within 5 days of receipt.

SHORTAGES Always check the contents of your delivery to insure all the parts that you ordered were received. Please read the invoice. Double check all packing materials, small items may be wrapped inside with these products. Shortages may occur from damage to the box, so save all packing materials. Inspect the box for holes that would allow parts to fall out. If you are missing any item(s) be sure to check your invoice for back orders or canceled items before calling the customer service department. If Speedway has to split a shipment into multiple boxes, packages may be delivered on different days. You need to contact the customer service department within 5 days of delivery to assure the prompt replacement. Speedway Motors assumes no liability after this period.

REFUSALS All refused COD customers will be billed a 15% restocking charge plus freight to and from the destination! If you have questions please contact Speedway's customer service department.

WARRANTY CLAIMS If an item has a manufacturer's warranty as being free from defects we will exchange only. If the item has been used and you are requesting warranty work, this may take up to 30 days as warranty work is done by the manufacturer NOT Speedway Motors. If you have any questions please contact customer service.

RETURNS Speedway wants you to be satisfied with your purchase. If within 30 days after you receive your shipment you are not satisfied, you may return the item for refund or exchange. All exchanged or returned merchandise must be in original factory condition with no modifications or alterations. Returned merchandise must include all packaging materials, warranty cards, manuals, and accessories. If the items being returned need to be repackaged there will be a re-packing charge. Re-pack the item in a sturdy box and include a copy of your invoice and complete the form on the back of the invoice. You must ship orders back **PRE-PAID. WE DO NOT ACCEPT COD SHIPMENTS.** All exchanges need to have reshipping charges included. Items that are returned after 30 days are subject to 15% restocking charges. All fiberglass returned will have 15% restocking charge. No returns on electrical parts, video tapes, and books. Absolutely no returns on special order or close out merchandise.

FREE CATALOGS Speedway Motors offers FREE catalogs for Race, Street, Sprint and Midget, Sport Compact and Pedal Car restoration.

**Some items are not legal for sale or use in California on pollution controlled motor vehicles. These items are legal in California for racing vehicles only which may never be used upon a highway.

Speedway Motors Inc,
P.O. Box 81906 Lincoln, NE 68501
(402) 323-3200
www.speedwaymotors.com



©Speedway Motors, Inc. 2007