

INSTRUCTIONS

910-31916

©Speedway Motors, Inc. Dec, 2011

5 LUG DISC BRAKE KIT FOR 1947-59 CHEVY TRUCKS

PARTS LIST

NOTES: Before beginning installation, make sure your wheels fit on the disc rotor. Also, this kit works only with 15" and larger wheel, due to the 11" rotors.

NOTE: On some applications it may be necessary to drill the lower spindle holes from 7/16" to 1/2".

INSTRUCTIONS:

1. Remove the drum and backing plate assemblies so all that remains are the stock spindles. Inspect the bearing surfaces on the spindle. If the spindle is grooved, a piece of 180-grit emery cloth can be used to clean it up.
2. Install the bearing adapter onto the spindle. The adapter will need to be heated so it can expand for easier installation. This can be achieved by placing it in boiling water or setting it on a night bulb for about 5 minutes.
3. Install the caliper mounting bracket on the spindle. The bracket should be installed on the outboard side of the spindle mount ears (closest to the rotor). It may be necessary to install spacers (included) between the spindle mount ears and the caliper mounting bracket for proper alignment.
4. Slide the caliper onto the bracket with the bleeder valve. The caliper may not slide into place due to a bump in the casting next to the piston bore. In some cases, it will be necessary to grind this bump flush using a bench grinder. Reinstall the caliper and turn the spindle full lock left and right to check for any interference. The caliper bracket should clear the kingpin lock nut. If not, reverse the nut so the nut is on the front of the axle. Remove caliper from bracket.
5. Take the inner bearing and slide it onto the bearing adapter. If the bearing will not go on, use a piece of 180-grit emery cloth to take down adapter.
6. Remove stock inner bearing cup from rotor and REPLACE with the TL68110 bearing cup from the included A13 bearing set. Grease the seals and install them along with the seals.
7. Slide rotor onto spindle. Pack and install outer bearing and secure with spindle washer and spindle nut. Adjust bearing preload as normal. Install the cotter pin and dust cap.
8. Install caliper with the bleeder valve. Make sure everything is tight and proceed to bleed the system.

WARNING: Stock drum brake wheels may not work with disc brake conversions. Drum brake wheels were not made with disc brakes in mind so there may be wheel to caliper clearance problems. Before installing this kit, make sure your wheels fit the brake assembly.

For those wanting to keep stock wheels that interfere with the installation, there are companies such as Wheelmite, Stockton Wheel Co. and Wheel Vintiques that can remove the original wheel centers and re-install them into a new disc brake rim.

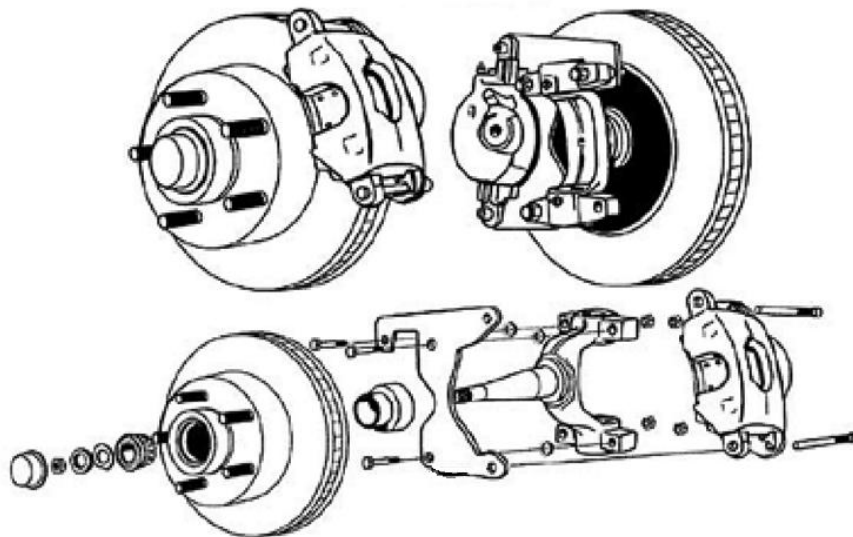

IMPORTANT

DISCLAIMER In an effort to offer our customers the low prices, quick service and great value, Speedway Motors reserves the right to change suppliers, specifications, colors, prices, materials. Each of the previous items is subject to change without notice. Speedway is not responsible for any typographical errors or misinterpretations. Quantities are limited on some items.

WARRANTY DISCLAIMER The purchaser understands and recognizes that racing parts, specialized street rod equipment, and all parts and services sold by Speedway Motors, Inc. are exposed to many and varied conditions due to the manner in which they are installed and used. Speedway Motors, Inc. makes no warranties, either express or implied, including any warranty of merchantability or fitness for a particular purpose other than those contained in its current catalog with respect to the goods identified on the face of the invoice. There is no warranty expressed or implied as to whether the goods sold hereby will protect purchaser or ultimate user of such goods from injury or death. Speedway Motors assumes no liability after this period.

DAMAGE CLAIMS Always inspect your package upon delivery. Inspect all packages in the presence of the delivery driver. The driver must note any damage. Ask the driver the Carrier's procedures for handling damage claims. You must hold the original box, packing material and damaged merchandise for inspection or the carrier will not honor the claim. Notify Speedway Motors customer service department for instructions on returning damaged goods. Speedway is not responsible if no notification is given within 5 days of receipt.

SHORTAGES Always check the contents of your delivery to insure all the parts that you ordered were received. Please read the invoice. Double check all packing materials, small items may be wrapped inside with these products. Shortages may occur from damage to the box, so save all packing materials. Inspect the box for holes that would allow parts to fall out. If you are missing any item(s) be sure to check your invoice for back orders or canceled items before calling the customer service department. If Speedway has to split a shipment into multiple boxes, packages may be delivered on different days. You need to contact the customer service department within 5 days of delivery to assure the prompt replacement. Speedway Motors assumes no liability after this period.

REFUSALS All refused COD customers will be billed a 15% restocking charge plus freight to and from the destination! If you have questions please contact Speedway's customer service department.

WARRANTY CLAIMS If an item has a manufacturer's warranty as being free from defects we will exchange only. If the item has been used and you are requesting warranty work, this may take up to 30 days as warranty work is done by the manufacturer NOT Speedway Motors. If you have any questions please contact customer service.

RETURNS Speedway wants you to be satisfied with your purchase. If within 30 days after you receive your shipment you are not satisfied, you may return the item for refund or exchange. All exchanged or returned merchandise must be in original factory condition with no modifications or alterations. Returned merchandise must include all packaging materials, warranty cards, manuals, and accessories. If the items being returned need to be repackaged there will be a re-packing charge. Re-pack the item in a sturdy box and include a copy of your invoice and complete the form on the back of the invoice. You must ship orders back **PRE-PAID. WE DO NOT ACCEPT COD SHIPMENTS.** All exchanges need to have reshipping charges included. Items that are returned after 30 days are subject to 15% restocking charges. All fiberglass returned will have 15% restocking charge. No returns on electrical parts, video tapes, and books. Absolutely no returns on special order or close out merchandise.

FREE CATALOGS Speedway Motors offers FREE catalogs for Race, Street, Sprint and Midget, Sport Compact and Pedal Car restoration.

**Some items are not legal for sale or use in California on pollution controlled motor vehicles. These items are legal in California for racing vehicles only which may never be used upon a highway.



Speedway Motors Inc., P.O. Box 81906
Lincoln, NE 68501 (402) 323-3200
www.speedwaymotors.com