



INSTALLATION INSTRUCTIONS TRANSMISSION COOLING PAN PART # 14208

Please read these instructions completely before beginning installation

KIT CONTENTS

QTY.	DESCRIPTION	QTY.	DESCRIPTION
1	Transmission Pan	2	10/32" Phillips Head Screws (pre-installed)
1	Magnetic Drain Plug	2	#10 Star Washers (pre-installed)
1	Rubber/Steel Washer	1	Filter Support (pre-installed)
1	1/8" NPT Plug		

TOOLS NEEDED

Ratchet
Long Extension
9/16" Socket
1/2" Socket
7/16" Socket
Phillips Screwdriver
Teflon Tape

IMPORTANT

Pre-installed in the transmission pan is a zinc plated Filter Support. The Filter Support must be used on all 4R100 & 5R110 transmissions. The Filter Support MUST be removed for all 5R110W applications. See Diagrams 1, 2 & 3 for details.

DETERMINING FILTER SUPPORT REQUIREMENTS

The Derales 14208 Transmission Cooling Pan is designed to work for Ford 4R100, 5R110, and 5R110W transmissions. All three transmissions utilize different filters which sit at different height locations within the pan. To accommodate this variance, pre-installed in the pan is a Filter Support. This Filter Support is designed to work for both 4R100 (1990 & Newer 4 Speed) and 5R110 transmissions (2003-2007 5 Speed) See Diagrams below. To utilize this pan on a 5R110W (2008 & Newer 5 Speed) the Filter Support MUST be removed.

REMOVING STOCK PAN

1. Drain the transmission fluid.
2. Remove all of the bolts mounting the pan to the transmission flange.
3. Remove the stock transmission pan
Note: If the stock pan utilized a 'reusable' rubber gasket, it can be used in place of the Derales gasket if desired. Be careful not to damage the rubber during pan removal.
4. Clean the mounting surface on the transmission. Remove any old gasket material with a gasket scraper being careful not to gouge the aluminum.

INSTALLING DERALES COOLING PAN

1. Install the drain plug and rubber/steel washer onto the bottom of the pan making sure it's sealed tight.
2. Install the 1/8" NPT plug or temperature sending unit (not supplied) using Teflon tape or other suitable sealant.
3. If using the Derales gasket, apply a thin coat of Gasegacinch or other suitable gasket sealer to the side of the gasket that will apply to the pan. Sealant should not be required on the transmission side.
4. Apply the gasket to the mounting surface of the pan.
5. Raise the pan up against the transmission and thread the mounting bolts in by hand starting with the opposing corners until all are installed.
6. Using a ratchet, extension, and 1/2" socket tighten the bolts to the factory torque specs working in an opposing pattern until all are secure. **Note:** Be sure not to over tighten bolts as the transmission is aluminum and can be easily stripped out if excessive force is applied.
7. Refill the transmission fluid by first adding 8-9 qts of fluid followed by starting the vehicle and shifting the transmission into the Neutral position.
8. Quickly check for any leaks around the mounting surface or plug holes.
9. While the vehicle is running add additional quarts until the fluid level is in the correct position on the dipstick.
10. Drive the vehicle for a short distance, making sure the transmission is warm and recheck fluid level. Add additional quarts as needed.

Diagram #1

4R100
(1990 & Newer 4-Speed)

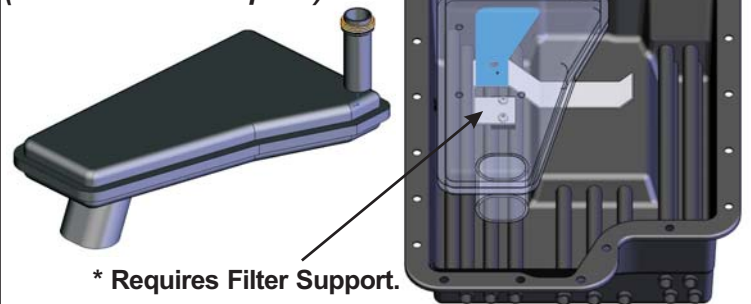

Diagram #2

5R110
(2003 - 2007 5-Speed)

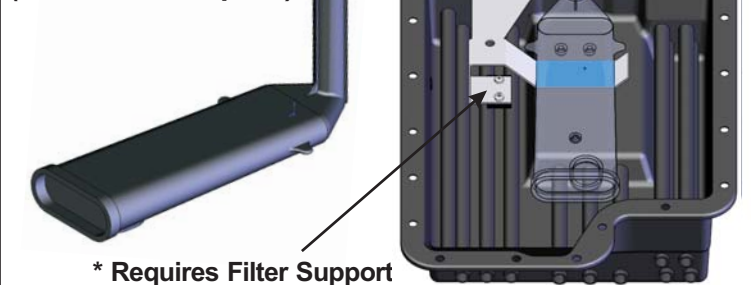

Diagram #3

5R110W
(2008 & Newer 5-Speed)

