

# INSTRUCTIONS

835-140150-INST



©Speedway Motors, Inc. January 2010

## Wilwood Brake Kit for '49-'54 Chevy Spindles

**Note: NOTE:** Disc brakes operate in a harsh environment. To prevent bolts from working loose, every threaded fastener should be secured by at least 1 redundant retaining method (safety lock wire, self locking nut, or red # 271 Loctite).

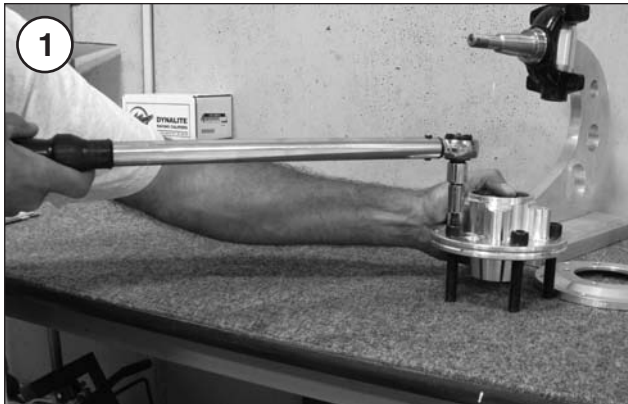

1) The hubs are drilled for 2 different bolt circle patterns, 5x 4.5" and 5x 4.75". Select the bolt circle that matches your vehicles wheels. Apply Loctite to the base of the threads of the wheel studs and install them into the appropriate holes. Torque to 77 ft lbs.

2) Install rotor adapter plate on hub (dished side of adapter plate should face hub). Install bolts and torque to 22 ft lbs, secure with lockwire.



3) Install rotor onto adapter plate (verify that beveled ID of rotor lugs face toward the adapter plate and that rotor is seated squarely on adapter). Install bolts and torque to 15 ft lbs, secure with lockwire.

Speedway Motors Inc.,  
P.O. Box 81906 Lincoln, NE 68501  
402-323-3200 [www.SpeedwayMotors.com](http://www.SpeedwayMotors.com)



4) Pack wheel bearings with quality high temp disc brake grease, insert large bearing into aft side of hub. Install grease seal until it seats flush with edge of hub.



5) Install hub assembly onto spindle, insert outer wheel bearing, retaining washer, and spindle nut. Snug spindle nut to 50 inch lbs, then back off to first available key slot and insert cotter pin. Install dust cap, checking closely for interference to cotter pin or washer.

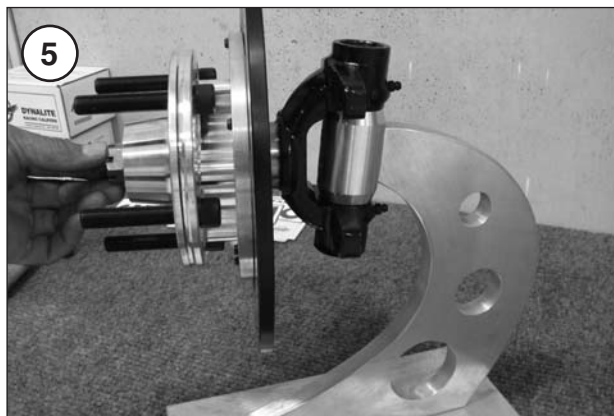

6) Install caliper on caliper bracket as shown. Use Loctite on bolt threads, torque to 30 ft lbs.

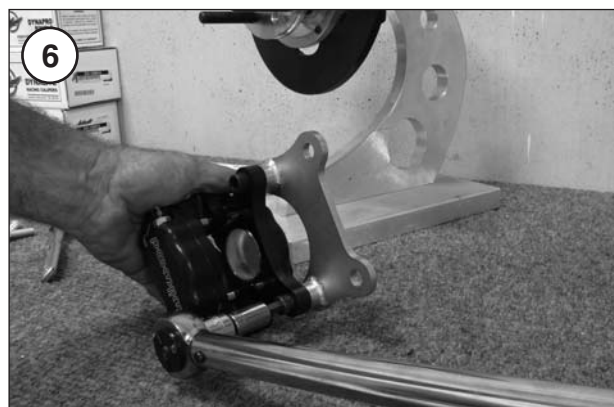

7) Install caliper and caliper bracket on spindle. Use supplied washers (as required) as shims to center the caliper on the rotor. Torque bolts to 50 ft lbs



8) Verify that hub and rotor spin freely with no interference or contact with caliper (refer to step 7 and re-shim if required). Insert brake pads into caliper and secure with pin.

## Important Notice - Read This First

Before any tear-down or disassembly begins, review the following information:

- Check wheel clearance to verify that there is adequate clearance with the wheels you will be using with the installation.
- Front brake kits do not include flex lines. OEM brake lines will not adapt to Wilwood calipers. Check the assembly instructions, or associated components section for brake line recommendations before assembly. In addition, Wilwood offers an extensive listing of brake lines and fittings on the web: [www.wilwood.com](http://www.wilwood.com).
- Due to OEM production differences and other variations from vehicle to vehicle, the fastener hardware and other components in this kit may not be suitable for a specific application or vehicle.
- It is the responsibility of the purchaser and installer of this kit to verify suitability/fitment of all components and ensure all fasteners and hardware achieve complete and proper engagement. Improper or inadequate engagement can lead to component failure.

## Exploded Assembly Diagram

WARNING INSTALLATION OF THIS KIT SHOULD ONLY BE PERFORMED BY PERSONS EXPERIENCED IN THE INSTALLATION AND PROPER OPERATION OF DISC BRAKE SYSTEMS. SPECIFIC PARTS MAY VARY FROM DIAGRAM

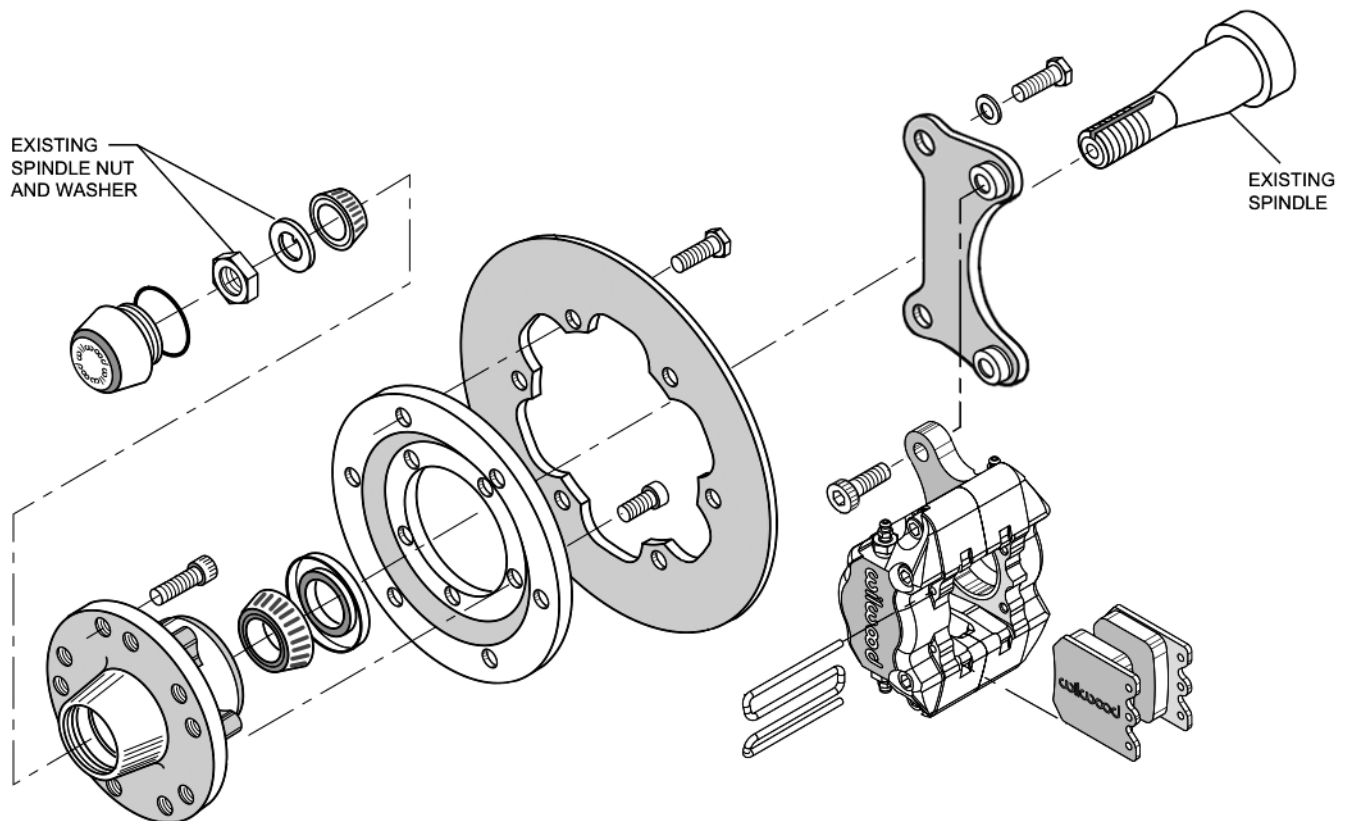

Speedway Motors Inc.,  
P.O. Box 81906 Lincoln, NE 68501  
402-323-3200 [www.SpeedwayMotors.com](http://www.SpeedwayMotors.com)



## Brake Testing and Pad Bedding

### **WARNING - DO NOT DRIVE ON UNTESTED BRAKES BRAKES MUST BE TESTED AFTER INSTALLATION OR MAINTENANCE MINIMUM TEST PROCEDURE**

- Make sure pedal is firm. Hold firm pressure on pedal for several minutes. It should remain in position without sinking. If pedal sinks toward floor, check system for fluid leaks. DO NOT drive vehicle if pedal does not stay firm or can be pushed to the floor with normal pressure.
- At very low speed (2 -5 mph) apply brakes hard several times while turning steering wheel from full left to full right. Repeat several times. Remove the wheels and check that components are not touching, rubbing or leaking.
- Carefully examine all brake components, brake lines and fittings for leaks and interference.
- Make sure there is no interference with wheels or suspension components.
- Drive vehicle at low speed (15-20 mph) making moderate and hard stops. Brakes should feel normal and positive. Again check for leaks and interference.
- Always test vehicle in a safe place where there is no danger to (or from) other people or vehicles.
- Always wear seat belts and make use of all safety equipment.

## Pad Bedding Procedure

- Pump brakes at low speed to assure proper operation. On the race track, or other safe location, make a series of hard stops until some brake fade is experienced. Allow brakes to cool while driving at moderate speed to avoid use of the brakes. This process will properly burnish the brake pads, offering maximum performance.

## Associated Components

| PART #   | DESCRIPTION  |
|----------|--|
| 260-1874 | Wilwood Residual Pressure Valve (2lb for disc brakes)      |
| 260-1876 | Wilwood Residual Pressure Valve (10lb for drum brakes)     |
| 260-8419 | Wilwood Proportioning Valve                                |
| 260-0632 | Wilwood Racing Brake Fluid (Hi-Temp 570°(12oz)             |
| 260-6209 | Wilwood Racing Brake Fluid (EXP 600 Plus (16.9 oz.)        |
| 340-1285 | Wilwood Floor Mount Brake Pedal (with balance bar)         |
| 340-1287 | Wilwood Swing Mount Brake Pedal (with balance bar)         |
| 260-6764 | Wilwood 3/4 inch High Volume Aluminum Master Cylinder      |
| 260-6765 | Wilwood 7/8 inch High Volume Aluminum Master Cylinder      |
| 260-6766 | Wilwood 1 inch High Volume Aluminum Master Cylinder        |
| 260-4893 | 1-1/16 inch Tandem Master Cylinder (Aluminum Housing)      |
| 260-2406 | Mounting Bracket Kit (Tandem Master Cylinder)              |
| 260-8555 | Wilwood 1 inch Aluminum Tandem Chamber Master Cylinder     |
| 260-8556 | Wilwood 1-1/8 inch Aluminum Tandem Chamber Master Cylinder |
| 350-2038 | 1971-1973 Pinto Rack and Pinion (new, not rebuilt)         |
| 260-2016 | Quick Release Steering Hub (3/4 inch shaft)                |
| 260-2017 | Quick Release Steering Hub (5/8 inch shaft)                |
| 220-7056 | Flexline Kit, Universal, 14 inch, Domestic                 |
| 220-7699 | Flexline Kit, Universal, 16 inch, Domestic                 |
| 220-8307 | Flexline Kit, Universal, 18 inch, Domestic                 |

# IMPORTANT

## **DISCLAIMER**

In an effort to offer our customers the low prices, quick service and great value, Speedway Motors reserves the right to change suppliers, specifications, colors, prices, materials. Each of the previous items is subject to change without notice. Speedway is not responsible for any typographical errors or misinterpretations. Quantities are limited on some items.

## **WARRANTY DISCLAIMER**

The purchaser understands and recognizes that racing parts, specialized street rod equipment, and all parts and services sold by Speedway Motors, Inc. are exposed to many and varied conditions due to the manner in which they are installed and used. Speedway Motors, Inc. makes no warranties, either express or implied, including any warranty of merchantability or fitness for a particular purpose other than those contained in its current catalog with respect to the goods identified on the face of the invoice. There is no warranty expressed or implied as to whether the goods sold hereby will protect purchaser or ultimate user of such goods from injury or death. Speedway Motors assumes no liability after this period.

## **BRAKE INSTALLATION ALERT**

**The selection and installation of brake components should only be done by personnel experienced in the proper installation and operation of braking systems. The installer must use his/her own discretion to determine the suitability of all brake components and brake kits for every particular application. Speedway Motors, Inc. makes no warranties either expressed or implied including any warranty of merchantability or fitness for a particular purpose, other than those contained in its current catalog or website with respect to the goods identified on the face of the invoice, There is no warranty expressed or implied as to whether the goods sold hereby will protect the purchaser or ultimate user of such goods from injury of death.**

## **DAMAGE CLAIMS**

Always inspect your package upon delivery. Inspect all packages in the presence of the delivery driver. The driver must note any damage. Ask the driver the Carrier's procedures for handling damage claims. You must hold the original box, packing material and damaged merchandise for inspection or the carrier will not honor the claim. Notify Speedway Motors customer service department for instructions on returning damaged goods. Speedway is not responsible if no notification is given within 5 days of receipt.

## **SHORTAGES**

Always check the contents of your delivery to insure all the parts that you ordered were received. Please read the invoice. Double check all packing materials, small items may be wrapped inside with these products. Shortages may occur from damage to the box, so save all packing materials. Inspect the box for holes that would allow parts to fall out. If you are missing any item(s) be sure to check your invoice for back orders or canceled items before calling the customer service department. If Speedway has to split a shipment into multiple boxes, packages may be delivered on different days. You need to contact the customer service department within 5 days of delivery to assure the prompt replacement. Speedway Motors assumes no liability after this period.

## **REFUSALS**

All refused COD customers will be billed a 15% restocking charge plus freight to and from the destination! If you have questions please contact Speedway's customer service department.

## **WARRANTY CLAIMS**

If an item has a manufacturer's warranty as being free from defects we will exchange only. If the item has been used and you are requesting warranty work, this may take up to 30 days as warranty work is done by the manufacturer NOT Speedway Motors. If you have any questions please contact customer service.

## **RETURNS**

Speedway wants you to be satisfied with your purchase. If within 30 days after you receive your shipment you are not satisfied, you may return the item for refund or exchange. All exchanged or returned merchandise must be in original factory condition with no modifications or alterations. Returned merchandise must include all packaging materials, warranty cards, manuals, and accessories. If the items being returned need to be repackaged there will be a re-packing charge. Re-pack the item in a sturdy box and include a copy of your invoice and complete the form on the back of the invoice. You must ship orders back **PRE-PAID. WE DO NOT ACCEPT COD SHIPMENTS.** All exchanges need to have reshipping charges included. Items that are returned after 30 days are subject to 15% restocking charges. All fiberglass returned will have 15% restocking charge. No returns on electrical parts, video tapes, and books. Absolutely no returns on special order or close out merchandise.

## **FREE CATALOGS**

Speedway Motors offers FREE catalogs for Race, Street, Sprint and Midget, Sport Compact and Pedal Car Restoration.

Some items are not legal for sale or use in California on pollution controlled motor vehicles. These items are legal in California for racing vehicles only which may never be used upon a highway.

**Speedway Motors Inc.,  
P.O. Box 81906 Lincoln, NE 68501  
402-323-3200 [www.SpeedwayMotors.com](http://www.SpeedwayMotors.com)**

