



Genuine Parts

**PRECAUTIONS:**

- ❑ Read ALL instructions before installing instrument.
- ❑ Follow ALL safety precautions when working on vehicle-wear safety glasses!
- ❑ ALWAYS disconnect (-) negative battery cable before making electrical connections.

**HELP?:**

- ❑ If after reading these instructions you don't fully understand how to install your instrument(s), contact your local Stewart Warner distributor, or contact our Technical Support Team toll free at **1-800-676-1837**
- ❑ Additional applications information may be found at [www.stewartwarner.com](http://www.stewartwarner.com).

**GENERAL APPLICATION:**

- ❑ 12-volt DC negative (-) ground electrical systems (11-20 VDC operating voltage range for the speedometer, 11-16 VDC for the Light bulb).

**Installation Instructions**  
*Tachometer 3-3/8"*

1

2

**TACHOMETER MOUNTING (Figure 1):**

- ❑ Recommended panel cut-out (hole size) for 3-3/8" tachometer is 3-3/8".
- ❑ Secure the tachometer in the hole using the supplied bracket and nuts. Be sure to wire the tachometer before mounting.

Figure 1

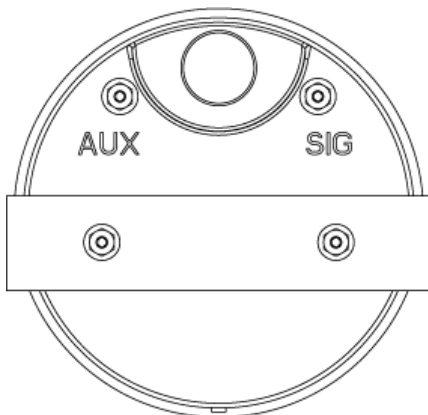

**TACHOMETER WIRING (Figure 2):**

1. Disconnect negative (-) battery cable.
2. Using 18-ga. wire, connect the **(NEG)** terminal to a clean (rust/paint-free) ground, preferably battery negative terminal.
3. Using 18-ga. wire, connect the **(POS)** terminal to a switched +12V source, like the ignition wire.
4. Using 18-ga. wire, connect the **(SIG)** terminal to the coil negative or the tachometer terminal of the ignition module.
5. There are two (2) wires for the lighting; Connect the **(WHITE)** lighting wire to the dash lighting circuit or to a +12V switched circuit. Connect the **(BLACK)** lighting wire to a chassis ground.
6. Calibrate the pulses per revolution (PPR). Refer to the calibration set-up section.
7. Reconnect the negative (-) battery cable & test instrument to ensure that it is working.
8. Never connect the **(SIG)** terminal to the coil when using an MSD or similar high output capacitive style ignition system.

3

4

Figure 2

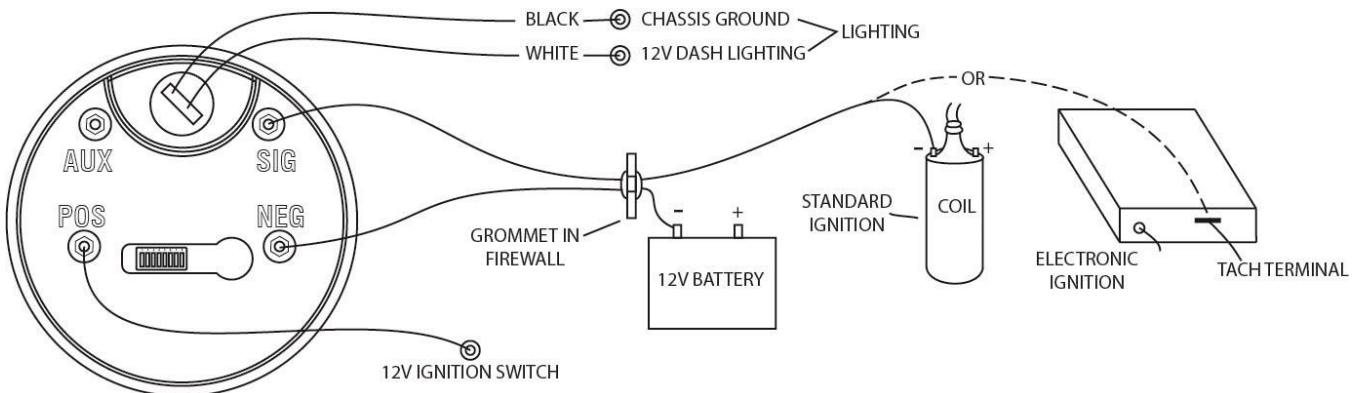

5

6

**CALIBRATION (PPR/Number of Cylinders):**

Until recently, tachometers were calibrated based on the number of cylinders in the engine. Now, there are all types of engine control modules (ECMs – on-board computers) and distributor less ignitions and the old standard rule – “half the number of cylinders equals the pulses per revolution (PPR)” – no longer applies. “Pulses per revolution” relates to how many times the ignition fires per crankshaft revolution. The tachometer outputs from ECMs can range from 1-PPR to 4-PPR for a V-8 engine. So, the new standard is to refer to PPR instead of the number of cylinders.

7

**CALIBRATION SET-UP (Figure 3):**

**NOTE:** Stewart Warner tachometers come pre-set for a standard 8 cylinder (4 PPR) application. See “DIP-switch setting chart” for additional applications.

1. Remove the rubber cover from the window on the back of the tachometer.
2. Refer to the “DIP-switch setting chart” (figure 3) to determine the settings for your application.
3. Make sure power is not applied to tachometer while setting DIP-switches.
4. Set the DIP-switches to the appropriate positions. (see switch setting chart).  
**TIP:** A small screw driver or pick may aide in the switch setting.
5. Replace the rubber cover on the switch window.

9

**TROUBLESHOOTING:**

**Q:** My tachometer does not respond at all, what do I do?

**A:** Check all of the wiring connections and power to the tachometer.

1. If the tachometer needle goes to zero when powered up, but does not respond when the engine is started, there is no signal to the **(SIG)** terminal. Check to ensure that the terminal is wired to the proper location for a valid signal.
2. If the tachometer needle does not go to zero when powered up, the tachometer is not grounded properly or does not have power to the **(POS)** terminal. Check to ensure a good chassis ground, preferably at the battery negative. Verify that the **(POS)** terminal has a 12VDC supply.

**Q:** My tachometer does not read correctly, what do I do?

**A:** First, determine how the reading is incorrect (example: Double, half, quarter, etc.), re-set DIP-switches for correct readings.

1. If the RPM reads double, re-set DIP-switches for 1/2 the PPR of the current setting.
2. If the RPM reads 1/2, re-set the DIP-switches for 2 times the current RPM setting.

11

**SIGNAL INTERFACING:**

Stewart Warner tachometers are designed to work with a wide variety of ignition types, including standard inductive [coil (-) connection] and any ignition system with a clean tachometer output signal. The input level can range from TTL 5V (outputs from newer engine control modules) and 300-400 volt pulses from coil (-) on most induction ignition systems. Stewart Warner tachometers will operate on most traditional capacitive discharge ignitions when connected to the ignition primary circuit. However, for high-output CD's (such as MSD) only connect to the tach output terminal, never the coil primary.

8

**Figure 3**

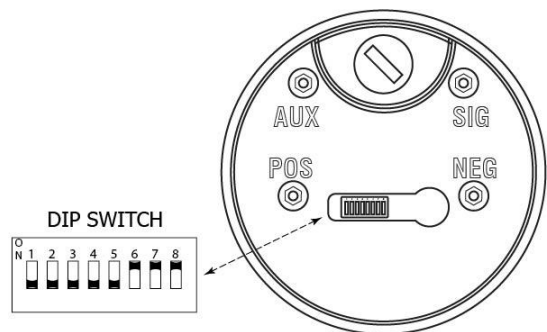

SWITCH SETTINGS		"X" = ON, "-" = OFF							
		1	2	3	4	5	6	7	8
0.5	PPR	-	-	-	-	-	-	-	-
1	PPR	-	-	-	-	-	-	-	X
1.5	PPR	-	-	-	-	-	-	X	-
2	PPR	-	-	-	-	-	-	X	X
2.5	PPR	-	-	-	-	X	-	-	-
3	PPR	-	-	-	-	X	-	X	X
4	PPR	-	-	-	-	X	X	X	X
5	PPR	-	-	-	X	-	-	-	X
6	PPR	-	-	-	X	-	X	X	X

10

**CLEANING DIRECTIONS:**

For proper cleaning of instrumentation/accessories, use a glass cleaner or mild detergent with a spray on and wipe method.

**WARRANTY INFORMATION:**

**TWO (2) YEAR LIMITED WARRANTY.** Stewart Warner products are warranted against defects in workmanship and materials for a period of two (2) years from the date of purchase. Proof-of-purchase is required; otherwise, the warranty period shall default to two (2) years from date-of-manufacture (as indicated by the date code on the product). See detailed Warranty Policy for other Terms & Conditions.

**STEWART WARNER**

1-800-676-1837

www.stewartwarner.com

12