

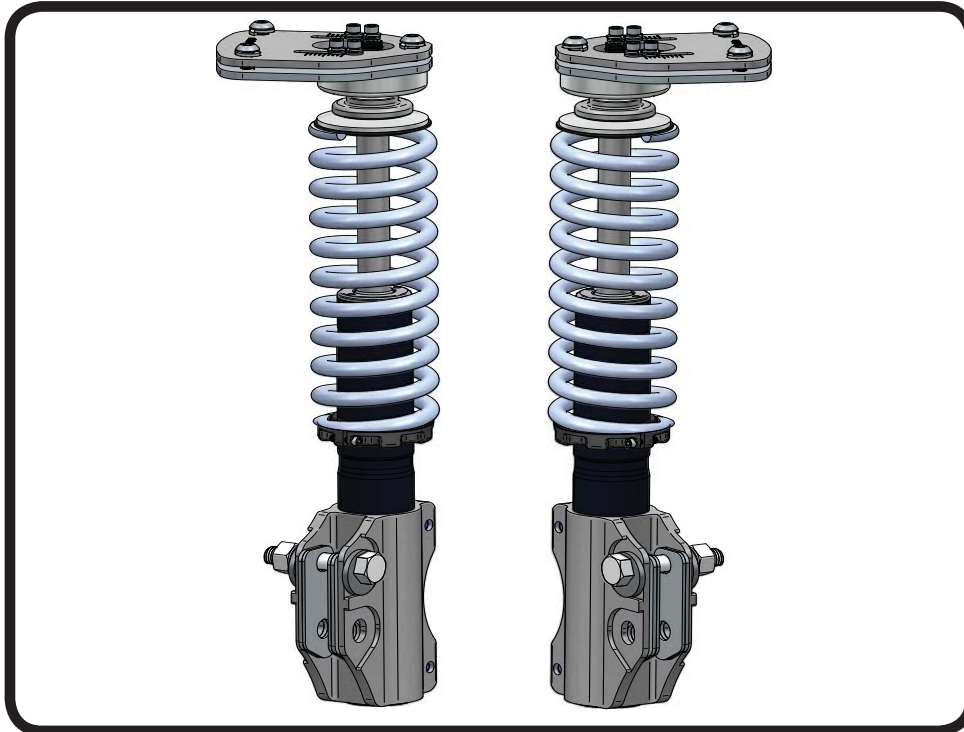

**Part # 12143110 -1994-2004 Mustang**

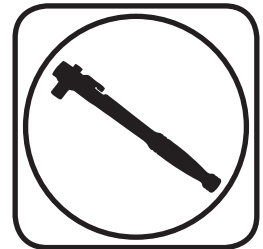

Recommended Tools



## 1994-2004 Mustang Front CoilOver Strut Installation Instructions

### Table of contents

- Page 2..... Included components
- Page 3..... Disassembly and Getting Started
- Page 4..... Upper Mount Assembly
- Page 5..... Final Assembly and Spring Adjustment & Preload
- Page 6..... Spring Adjustment and Strut Adjustment





### Included Components ....In the box

Item #	Part #	Description	QTY
1	27569999	Strut Cartridge	2
2	90002470	Bearing Retaining Mount	2
3	70012100	Upper Caster Plate-Driver(Shown)	1
3	70012101	Upper Caster Plate-Pass	1
4	90002469	Lower Caster Plate	2
5	70011289	Strut Extrusion	2
6	90002368	Thrust Bearing Adapter	2
7	70010987	Thrust Bearing	2
8	70010988	Thrust Bearing Washer	4
9	90001042	Upper Mount Bearing	2
10	90000805	Bearing Snap Ring	2
11	99562003	9/16"-18 Nylok Nut	2
12	90002222	Coil Spring Retaining Kit	2
13	59100200	CoilSpring	2
14	70010828	Delrin Coil Spring Washers	4
15	90000801	Eccentric Bolt	2
16	70010992	Strut Retaining Ring	2
17	99371042	3/8"-16 x 1" SHCS	6
18	70012031	Spindle Spacer-.120" Thick	4
19	70012032	Spindle Spacer-.097" Thick	4
20	99371029	3/8"-16 x 3/4" BHSC	6
21	99373010	3/8" Split Lock Washer	6
22	99251012	1/4"-20 x 1 1/4" SHCS	8
23	99253009	1/4" Flat Washer	8
24	99253007	1/4" Split Lock Washer	8
25	90002365	Coil Spring ro Bearing Adapter	2
	90002263	Tube Red Loctite	1
	90002276	Tube Anti-sieze	1

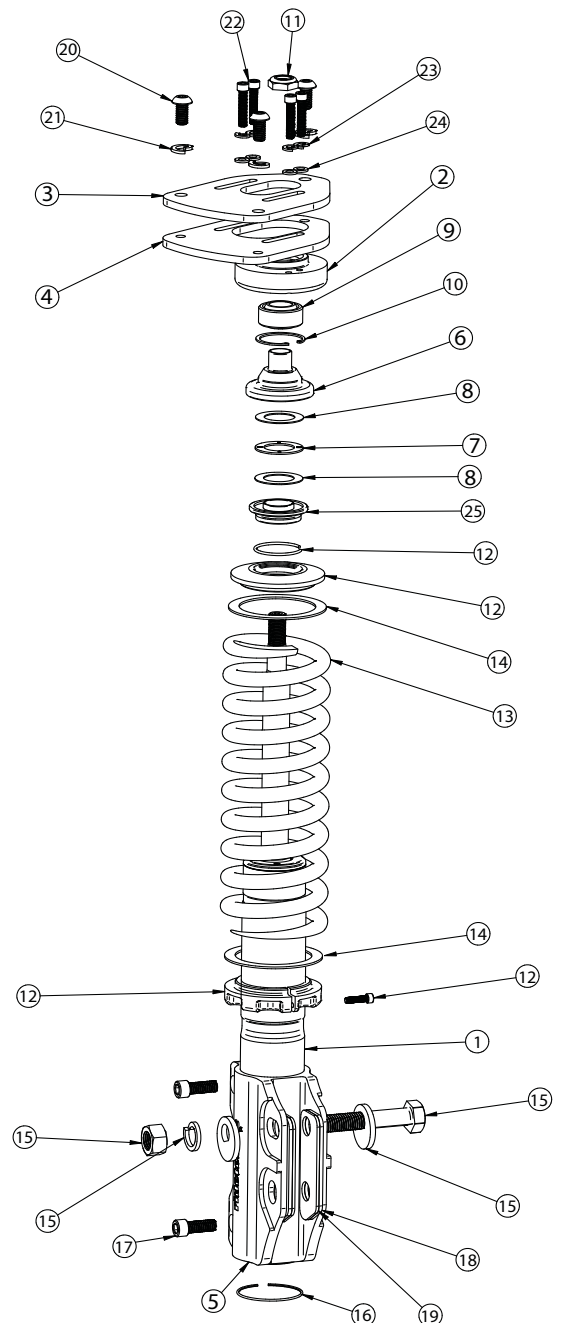



### Disassembly

1. This kit will replace the OEM Strut, Coil Spring, and Upper Strut Mount. These items will need to be removed from the car. It will be necessary to disconnect the Swaybar from the Lower Control Arm and remove the Disc Brake Caliper from the spindle, **DO NOT LET THE CALIPER HANG BY THE BRAKE LINE.** Refer to the factory service manual for disassembly procedure...
2. Support the front hub and control arm assembly and remove the (2) struts bolts(retain hardware) that attach the strut to the spindle.
3. Remove the (3) nuts holding the upper strut mount to the car body. **DO NOT REMOVE THE CENTER NUT.**
4. Remove strut assembly from the car.

### Getting Started

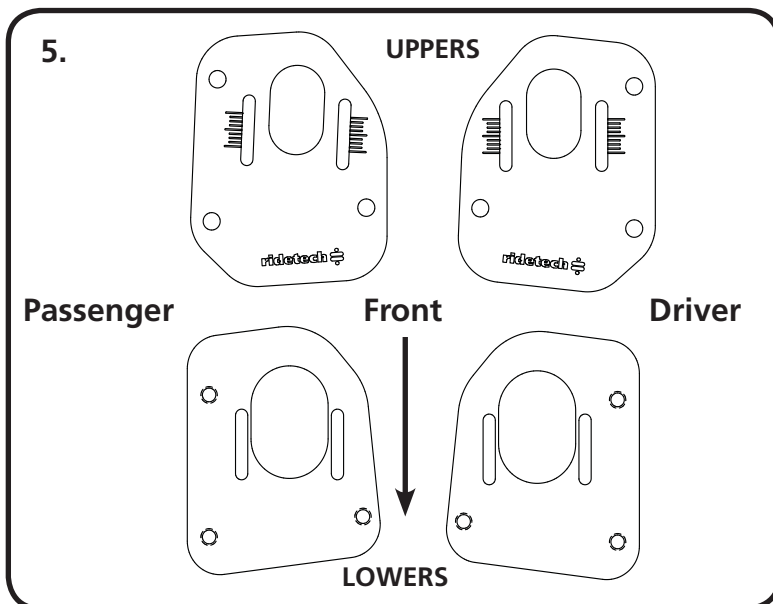

5. The upper strut mount provided in this kit has been designed to provide the ability to get more caster adjustment than the OEM setup. Camber adjustment is done at the spindle mount. The Caster Plate Assembly consists of 2 Plates per side, the Upper Plate is specific to each side. The Lower Steel plate is the same for each side. The Steel Plate is installed on the bottom side of the Strut Tower and the Aluminum Plate is installed on the top of the strut tower. The Aluminum Upper Plate is installed with the Ridetech Logo readable from the front of the car. If the logo is upside down when standing at the front of the car, the plate is installed on the incorrect side.

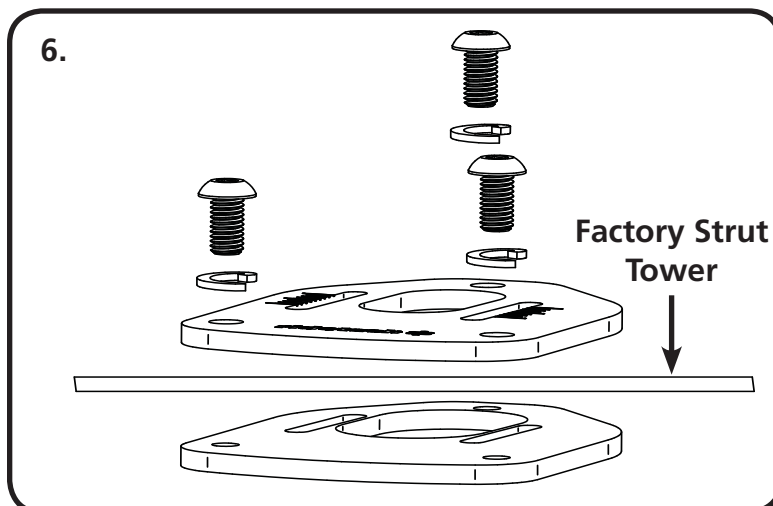

6. Use Illustration 6 to help you determine the correct position and orientation of the Caster Plates. Position the Steel Plate on the bottom side of the Factory Strut Tower. Lay the Aluminum Upper Plate on top of the Strut Tower aligning the 3 holes with the holes in the Tower. Apply Red Loctite to (3) 3/8" x 3/4" Button Head Bolts. Install a 3/8" Lock Washer on each Bolt and thread one in each hole of the Upper & Plate. Tighten all 3 bolts on each side. The slots in the Upper & Lower Plates should line up.



### Upper Mount Assembly

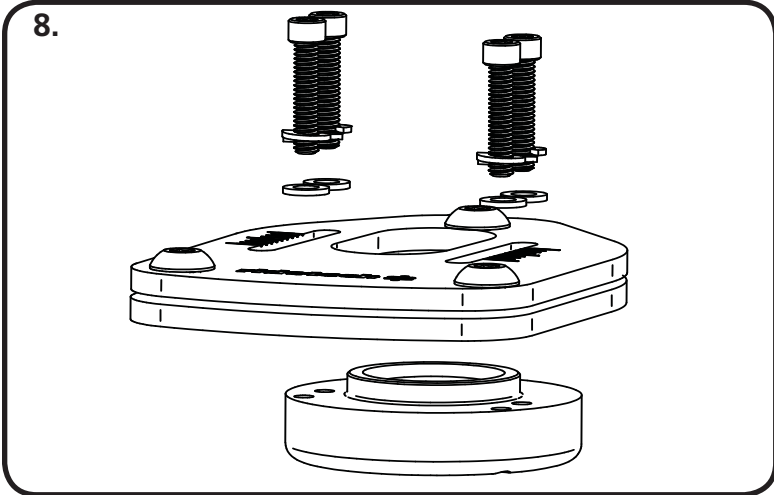

8. Attach the Bearing Housing to the Caster Plate Assembly. The Housing is positioned with the 4 threaded bolt holes to the front of the car lining 2 holes up with each slot. Insert the housing up from the bottom. Apply Antiseize to the threads of each of the (4) 1/4" x 1 1/4" Socket Head Bolts. Install a 1/4" Lock Washer and Flat Washer on each bolt. The bolts will be inserted through the caster plate with 2 bolts in each slot threading into the Bearing Housing.

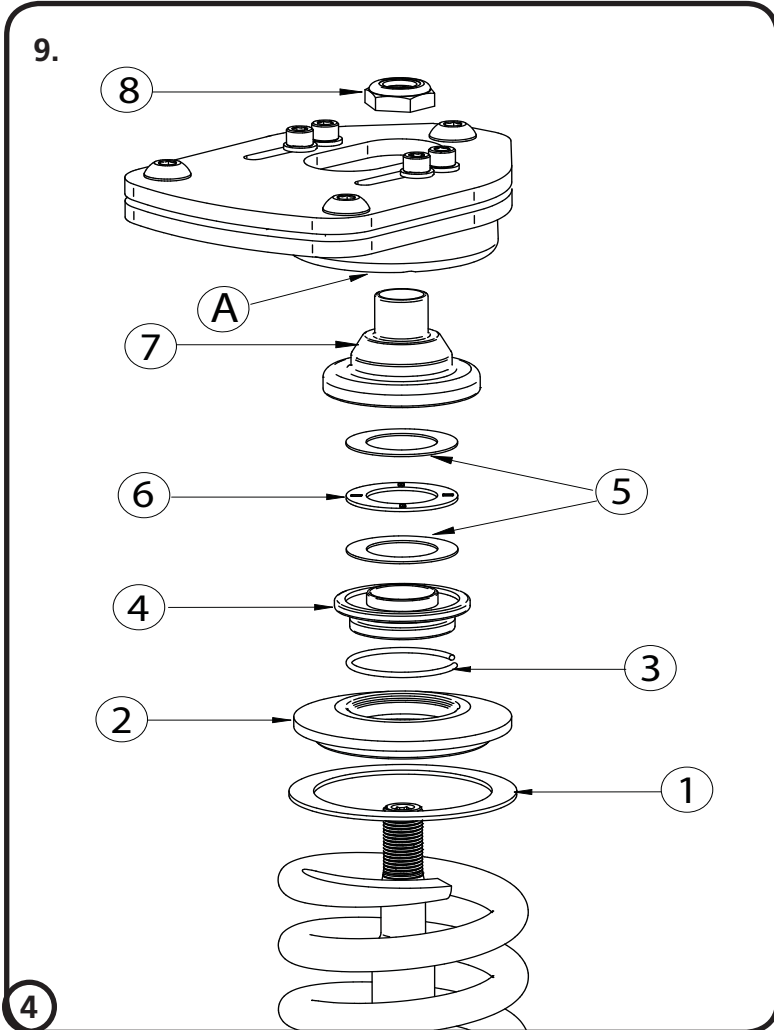

9. Remove the Adjuster Knob from the Strut shaft for assembly. With the CoilSpring installed on the Strut, bolt the strut assembly into the upper mount (A), see diagram 11 for assembly order.

1. Delrin CoilSpring Washer
2. Upper CoilSpring Cap
3. CoilSpring Cap Retaining Ring (Installed On #4 CoilSpring to Bearing Adapter)
4. CoilSpring to Bearing Adapter
5. Torrington Bearing Races
6. Torrington Bearing
7. Bearing Adapter (Small Diameter Up)
8. 9/16" Locknut

Assemble components and install into upper mount tightening upper nut. Reinstall upper adjustment knob.



### Assembly

10.

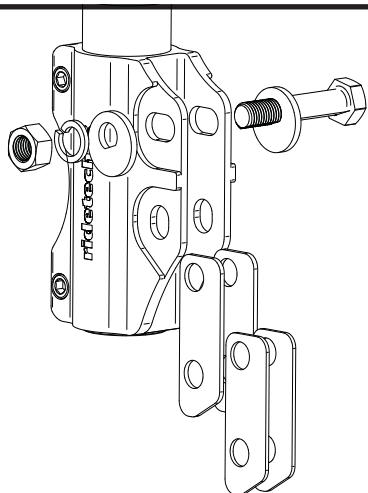

10. Due to various thickness of the spindles, the kit comes with shims for the spindle. It may necessary to run multiple shims of some. If multiple shims are required, install (1) Thick and (1) Thin on each side of the spindle. The lower Strut mounting holes reuses the OEM Bolt. The upper Slotted holes use the 16mm Eccentric Bolt provided in the kit. This Eccentric Bolt is used for camber adjustment.

**NOTE:** Torque Strut Mounting Bolts to 135 ftlbs

11. Repeat previous steps on Passenger side.
12. After both sides are installed, reattached the Sway Bar Linkage and Reinstall the Brake Caliper.
13. It will be necessary to have the car aligned after installing the Ridetech Strut Setup.

### Spring Adjustment and Preload

#### Ride Height

We have designed most cars to have a ride height of about 2" lower than factory. To achieve the best ride quality & handling, the shock absorber needs to be at 40-60% overall travel when the car is at ride height. This will ensure that the shock will not bottom out or top out over even the largest bumps. Measuring the shock can be difficult, especially on some front suspensions. Measuring overall wheel travel is just as effective and can be much easier. Most cars will have 4-6" of overall wheel travel. One easy way to determine where you are at in wheel travel is to take a measurement from the fender lip (center of the wheel) to the ground. Then lift the car by the frame until the wheel is just touching the ground, re-measure. This will indicate how far you are from full extension of the shock. A minimum of 1.5" of extension travel (at the wheel) is needed to ensure that the shock does not top out. If you are more than 3" from full extension of the shock then you are in danger of bottoming out the shock absorber.



### Spring Adjustment and Preload continued.....

#### Adjusting Spring Height

When assembling the CoilOver, screw the spring retainer tight up to the spring (0 preload). After entire weight of car is on the wheels, jounce the suspension and roll the car forward and backward to alleviate suspension bind.

- If the car is too high w/ 0 preload then a smaller rate spring is required. Although threading the spring retainer down would lower the car, this could allow the spring to fall out of its seat when lifting the car by the frame.
- If the car is too low w/ 0 preload, then preload can then be added by threading the spring retainer up to achieve ride height. On 2.6" - 4" stroke shocks, up to 1.5" of preload is acceptable. On 5-7" stroke shocks, up to 2.5" of preload is acceptable. If more preload is needed to achieve ride height a stiffer spring rate is required. Too much preload may lead to coil bind, causing ride quality to suffer.

### Strut Adjustment

#### Strut Adjustment 101- Single Adjustable

##### Rebound Adjustment:

How to adjust your new struts.

The rebound adjustment knob is located on the top of the Strut protruding through the upper mount.

You must first begin at the ZERO setting, then set the shock to a soft setting of 20.



-Begin with the Strut adjusted to the ZERO rebound position (full stiff). Do this by rotating the rebound adjuster knob clockwise until it stops.

-Now turn the rebound adjuster knob counter clock wise 20 clicks. This sets the shock at 20. (settings 21-24 are typically too soft for street use).

##### Take the vehicle for a test drive.



-If you are satisfied with the ride quality, do not do anything, you are set!

-If the ride quality is too soft increase the damping effect by rotating the rebound knob clock wise 3 clicks.

##### Take the vehicle for another test drive.



-If the vehicle is too soft increase the damping effect by rotating the rebound knob clock wise 3 additional clicks.

-If the vehicle is too stiff rotate the rebound adjustment knob counter clock wise 2 clicks and you are set!

Take the vehicle for another test drive and repeat the above steps until the ride quality is satisfactory.

##### Note:

**One end of the vehicle will likely reach the desired setting before the other end. If this happens stop adjusting the satisfied end and keep adjusting the unsatisfied end until the overall ride quality is satisfactory.**