

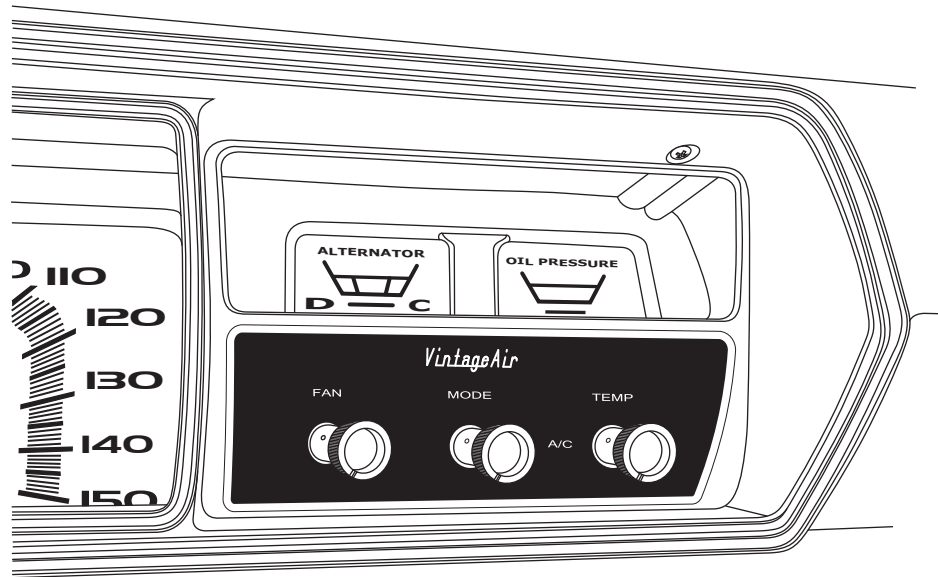

an ISO 9001:2008 Registered Company

# 1966-67 Plymouth Belvedere, Satellite, GTX

Control Panel Kit  
474153



18865 Goll St. San Antonio, TX 78266  
Phone: 210-654-7171  
Fax: 210-654-3113  
[www.vintageair.com](http://www.vintageair.com)



www.vintageair.com

# Table of Contents

---

Cover.....	1
Table of Contents.....	2
Packing List/Parts Disclaimer.....	3
Removing OEM Control Panel.....	4
Control Panel Installation.....	5
Wiring Diagram.....	6
Operation of Controls.....	7
Packing List.....	8



www.vintageair.com

# Packing List: Control Panel Kit (474153) 1966-67 Plymouth Belvedere, Satellite, GTX

No.	Qty.	Part No.	Description
1.	1	473051	Control Panel Assembly
2.	1	232007-VUR	Control Harness, Gen IV Universal
3.	1	21301-VUP	Tie Wrap, 4"

**\*\* Before beginning installation, open all packages and check contents of shipment. Please report any shortages directly to Vintage Air within 15 days. After 15 days, Vintage Air will not be responsible for missing or damaged items.**

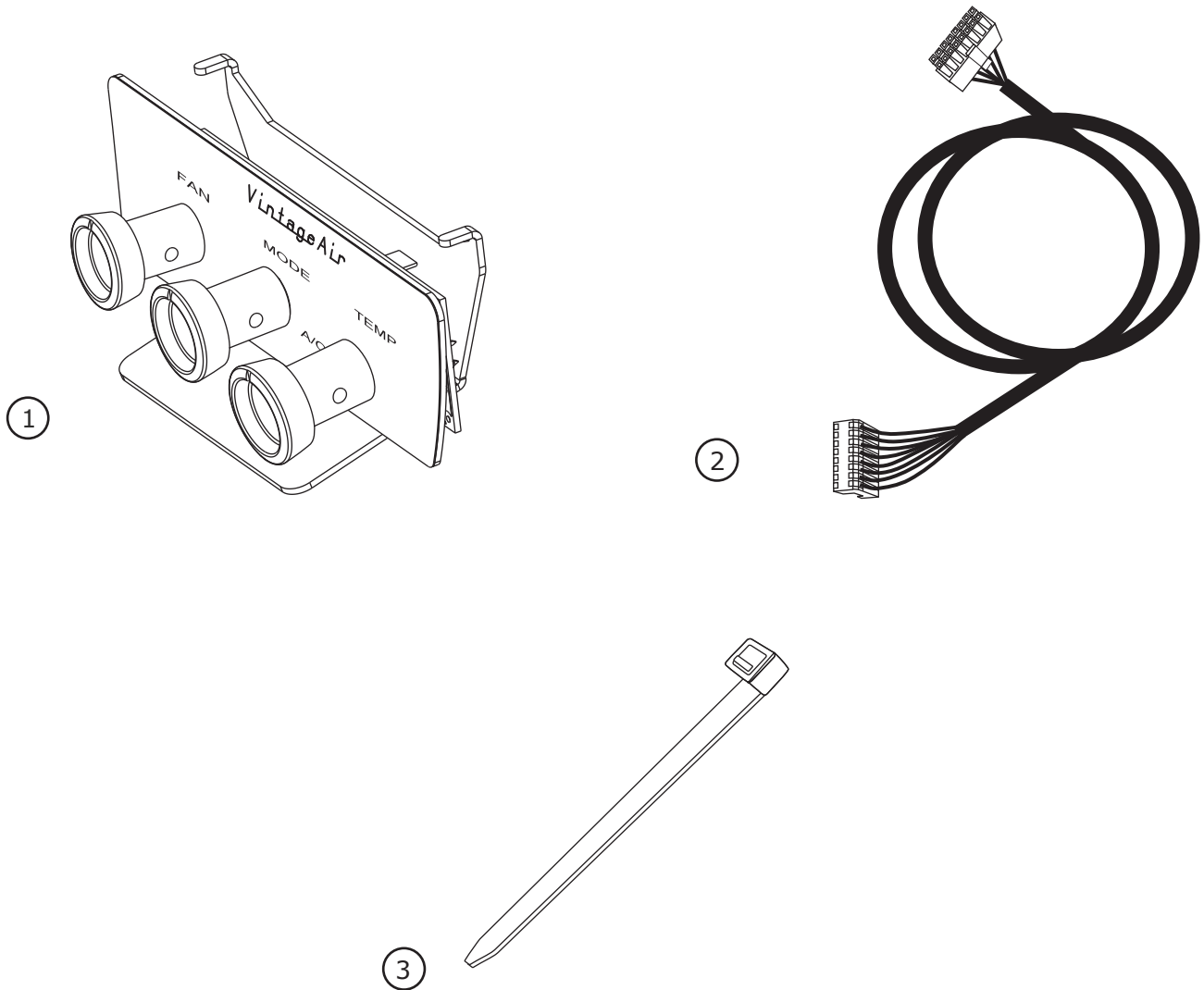

**NOTE: Images may not depict actual parts and quantities.  
Refer to packing list for actual parts and quantities.**



www.vintageair.com

## Removing OEM Control Panel (with Factory Air)

### Perform the Following:

1. Disconnect cables and wires from the back side of the OEM controls (discard).
2. Remove (2) OEM screws from the control panel (discard).
3. Remove the OEM control panel (discard).

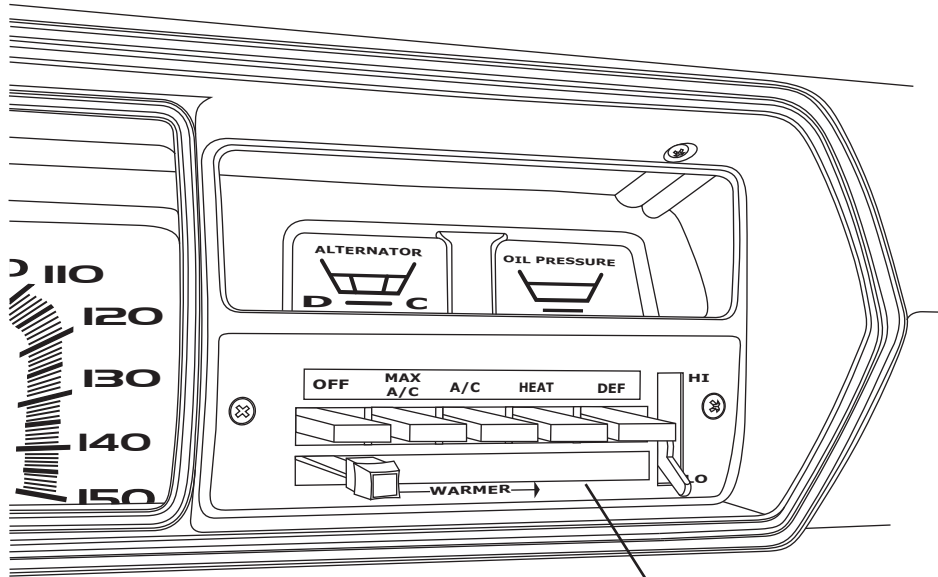

**Figure 1**

Remove OEM  
Control Panel

## Removing OEM Control Panel (without Factory Air)

### Perform the Following:

1. Disconnect cables and wires from the back side of the OEM controls (discard).
2. Remove (2) OEM screws from the control panel (discard).
3. Remove the OEM control panel (discard).

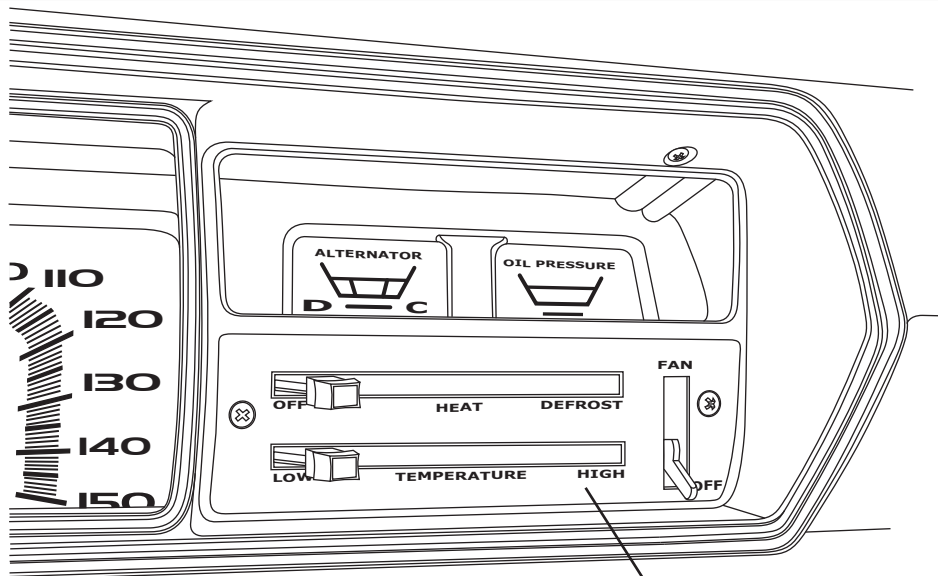

**Figure 2**

Remove OEM  
Control Panel



www.vintageair.com

## Control Panel Installation

1. Tie wrap the control panel harness to the control panel rear bracket, keeping the control panel connector 12" from the tie wrap (See Figure 3, below).
2. Locate the (2) vacant threaded holes in the dash casting, set back along the top edge of the control panel opening. Place the control panel rear bracket behind the dash, and insert the fingers of the rear bracket into the threaded dash holes. Holding the bracket in this position, feed the control panel connector out through the control panel opening in the dash, and plug the connector into the PC board on the back side of the control panel as shown in Figure 3, below.
3. Feed the control panel harness slack back through the dash opening. With a 5/32" Allen wrench driver bit, hand tighten the supplied bolt and washer to secure the rear bracket to the control panel (See Figures 3 & 4, below).
4. Plug the opposite end of the control panel harness into the ECU as shown in Figure 3, below.

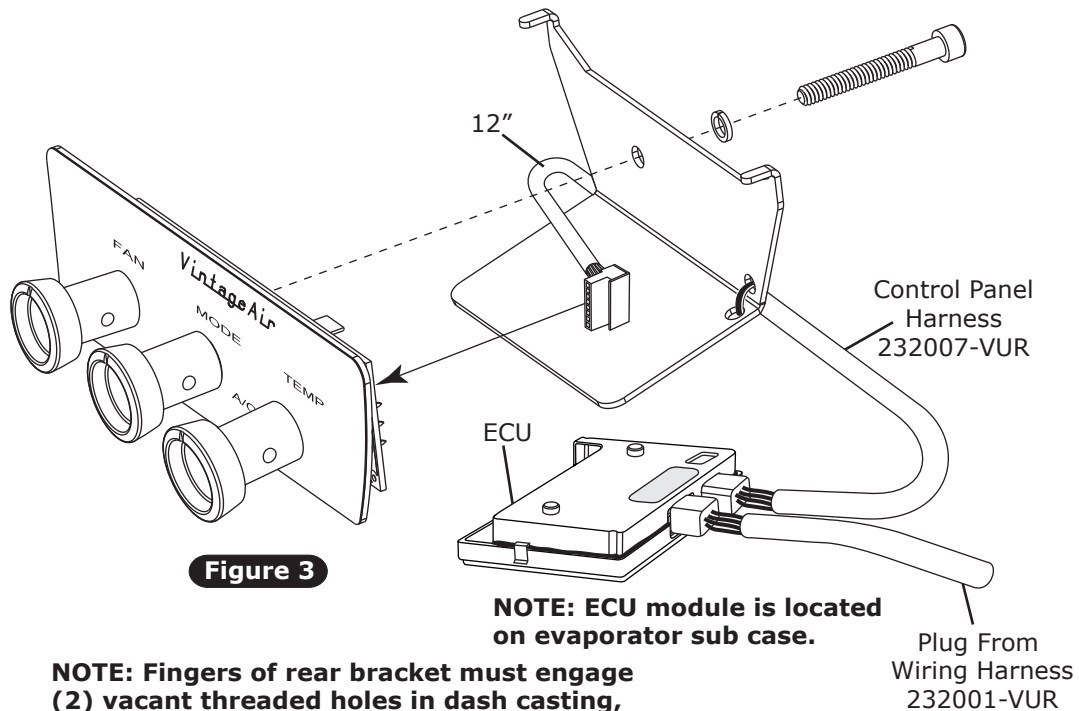

**NOTE: Fingers of rear bracket must engage (2) vacant threaded holes in dash casting, set back along the top edge of the control panel opening in the dash.**

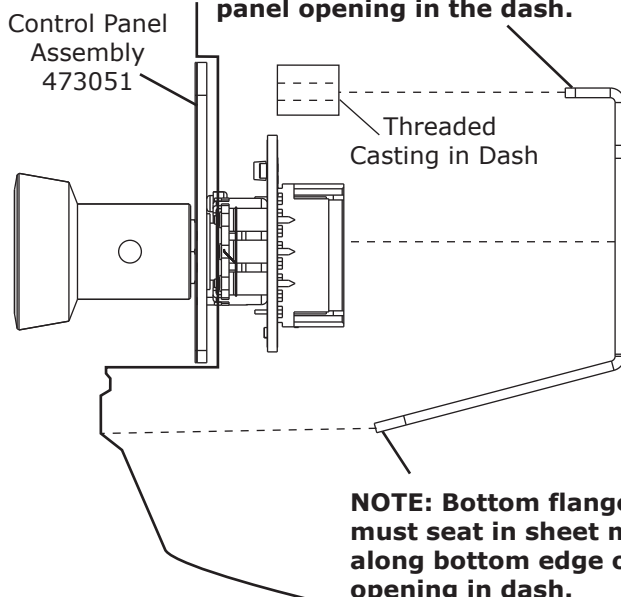

**Figure 4**



www.vintageair.com

# Wiring Diagram

232007-VUR

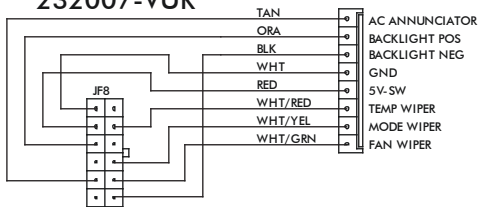

VIEWED FROM WIRE SIDE

232002-VUA

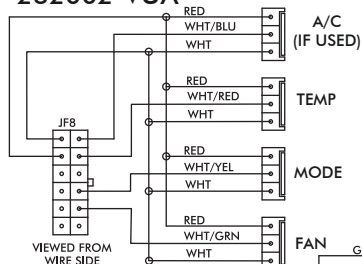

VIEWED FROM WIRE SIDE

GEN IV ECU

GEN IV WIRING DIAGRAM  
REV D, 5/6/2014

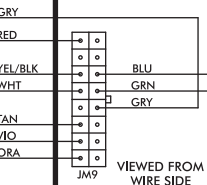

VIEWED FROM WIRE SIDE

PRE-WIRED

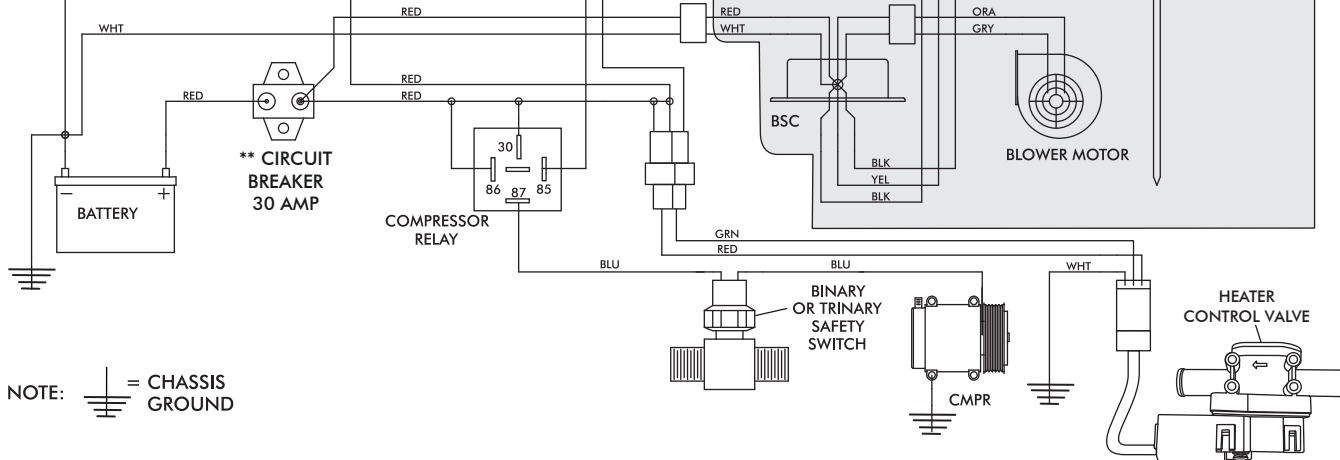
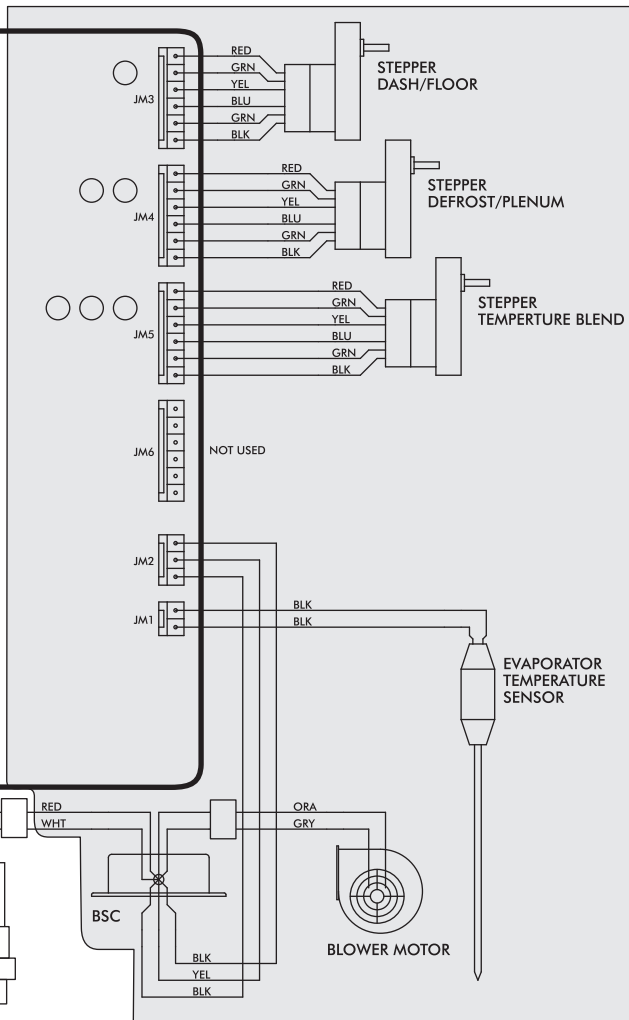

NOTE: = CHASSIS GROUND

- Dash Lamp Is Used Only With Type 232007-VUR Harness.
- **Warning:** Always Mount Circuit Breaker As Close to the Battery As Possible. (NOTE: Wire Between Battery and Circuit Breaker Is Unprotected and Should Be Carefully Routed to Avoid a Short Circuit).
- Wide Open Throttle Switch Contacts Close Only at Full Throttle, Which Disables A/C Compressor.



www.vintageair.com

## Operation of Controls

On Gen IV systems with three lever/knob controls, the temperature control toggles between heat and A/C operations. To activate A/C, move the temperature lever/knob all the way to cold and then back it off to the desired vent temperature. For heat operation, move the temperature lever/knob all the way to hot and then adjust to the desired vent temperature. The blower will momentarily change speed, each time you toggle between operations, to indicate the change.

### Blower Speed

This lever/knob controls blower speed, from OFF to HI.

### Mode Control

This lever/knob controls the mode positions, from DASH to FLOOR to DEFROST, with a blend in between.

### Temperature Control

This lever/knob controls the temperature, from HOT to COLD.

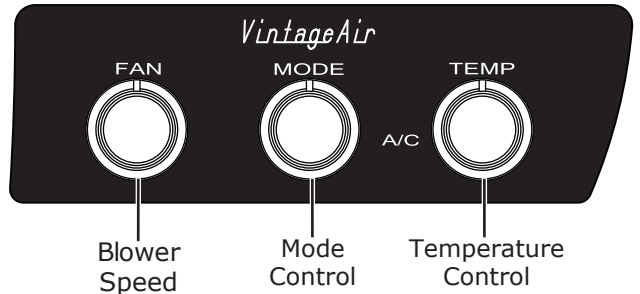

## A/C Operation

### Blower Speed

Adjust to desired speed.

### Mode Control

Adjust to desired mode position (DASH position recommended).

### Temperature Control

For A/C operation, adjust to coldest position to engage compressor (Adjust between HOT and COLD to reach desired temperature).



## Heat Operation

### Blower Speed

Adjust to desired speed.

### Mode Control

Adjust to desired mode position (FLOOR position recommended).

### Temperature Control

For maximum heating, adjust to hottest position (Adjust between HOT and COLD to reach desired temperature).



## Defrost/De-fog Operation

### Blower Speed

Adjust to desired speed.

### Temperature Control

Adjust to desired temperature.

### Mode Control

Adjust to DEFROST position for maximum defrost, or between FLOOR and DEFROST positions for a bi-level blend (Compressor is automatically engaged).





www.vintageair.com

# Packing List: Control Panel Kit (474153) 1966-67 Plymouth Belvedere, Satellite, GTX

No.	Qty.	Part No.	Description
1.	1	473051	Control Panel Assembly
2.	1	232007-VUR	Control Harness, Gen IV Universal
3.	1	21301-VUP	Tie Wrap, 4"

Checked By: \_\_\_\_\_  
Packed By: \_\_\_\_\_  
Date: \_\_\_\_\_

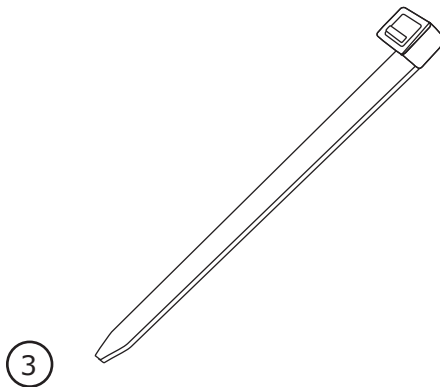
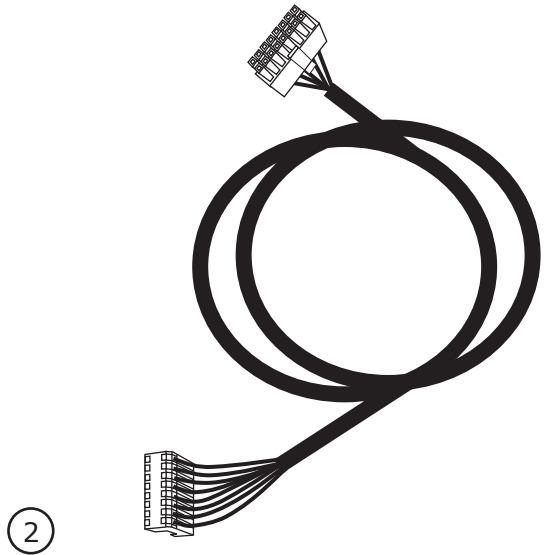
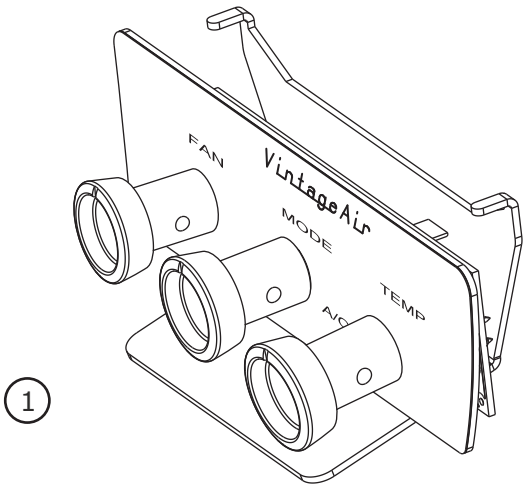

**NOTE: Images may not depict actual parts and quantities.  
Refer to packing list for actual parts and quantities.**