



an ISO 9001:2000 Registered Company

1967-68 MUSTANG

CONDENSER WITH DRIER

011068

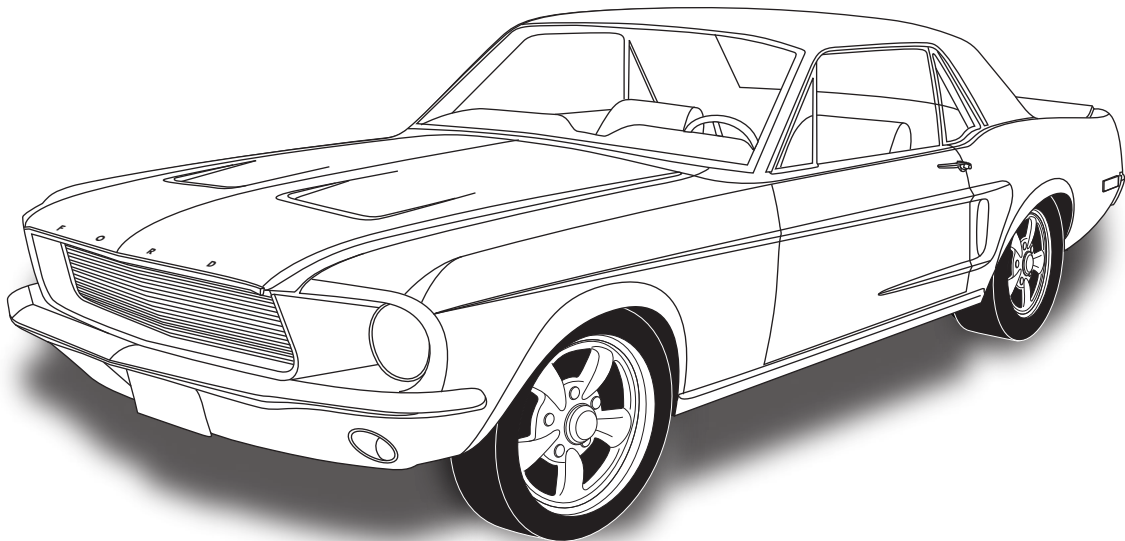

18865 GOLL ST. - SAN ANTONIO, TX. - 78266 ph.210-654-7171 - fax 210-654-3113



TABLE OF CONTENTS

PAGES

1. COVER
2. TABLE OF CONTENTS
3. PACKING LIST/PARTS DISCLAIMER
4. INFORMATION PAGE
5. CONDENSER BRACKET INSTALLATION
6. DRIER AND MOUNTING BRACKET INSTALLATION
FIGURES 1 & 2
7. DRIER INSTALLATION & HARDLINE INSTALLATION
FIGURES 3 & 4
8. RADIATOR REMOVAL & CORE SUPPORT MODIFICATION
FIGURES 5 & 6b
9. CONDENSER ASSEMBLY & FAN SHROUD INSTALLATION
FIGURES 7 & 8
10. HARDLINE & BINARY SWITCH INSTALLATION
FIGURES 9 & 9a
11. HORN BRACKET MODIFICATION
FIGURE 10
12. CORE SUPPORT MODIFICATION TEMPLATE
13. PACKING LIST



1967-68 MUSTANG CONDENSER WITH DRIER

CONDENSER KIT
011068

No.	QTY.	PART NO.	DESCRIPTION
1.	1	03765-VUC	SUPER FLOW CONDENSER 14 X 20
2.	1	07321-VUC	DRIER
3.	2	07113-VUB	DRIER CLAMP
4.	1	65998-VUB	UNIVERSAL DRIER BRKT 14 3/4
5.	1	642073	67-70 MUSTANG RAD CORE HARDLINE SUPPORT BRKT
6.	1	642070	67-70 MUSTANG DS COND BRKT
7.	1	642069	67-70 MUSTANG PS COND BRKT
8.	1	081095	#6 DR/CORE HARDLINE
9.	1	08164-PFL	#6 DRIER/COND HARDLINE
10.	1	081068	#8 COND HARDLINE
11.	12	18260-VUB	10/24 NUT WITH STAR WASHER
12.	12	18249-VUB	10/24 X 3/8 PAN HEAD SCREW
13.	3	33857-VUF	#6 O-RING
14.	1	33858-VUF	#8 O-RING
15.	3	18247-VUB	#10 X 1/2 SHEETMETAL SCREW
16.	1	11079-VUS	MALE BINARY SWITCH
17.	1	23135-VUW	COMPRESSOR LEAD
18.	1	33134-VUI	GROMMET
19.	1	31600-VUD	#2 ADEL CLAMP
20.	1	18287-VUB	1/4-20 X 1/2 HEX BOLT
21.	5	18125-VUB	1/4 FLAT WASHER
22.	1	18152-VUB	1/4-20 NUT WITH STAR WASHER
23.	4	18290-VUB	1/4-20 X 1 HEX BOLT
24.	4	18978-VUB	1/4 U-NUT

**** BEFORE BEGINNING INSTALLATION OPEN ALL PACKAGES AND CHECK CONTENTS OF SHIPMENT. PLEASE REPORT ANY SHORTAGES DIRECTLY TO VINTAGE AIR WITHIN 15 DAYS. AFTER 15 DAYS, VINTAGE AIR WILL NOT BE RESPONSIBLE FOR MISSING OR DAMAGED ITEMS.**

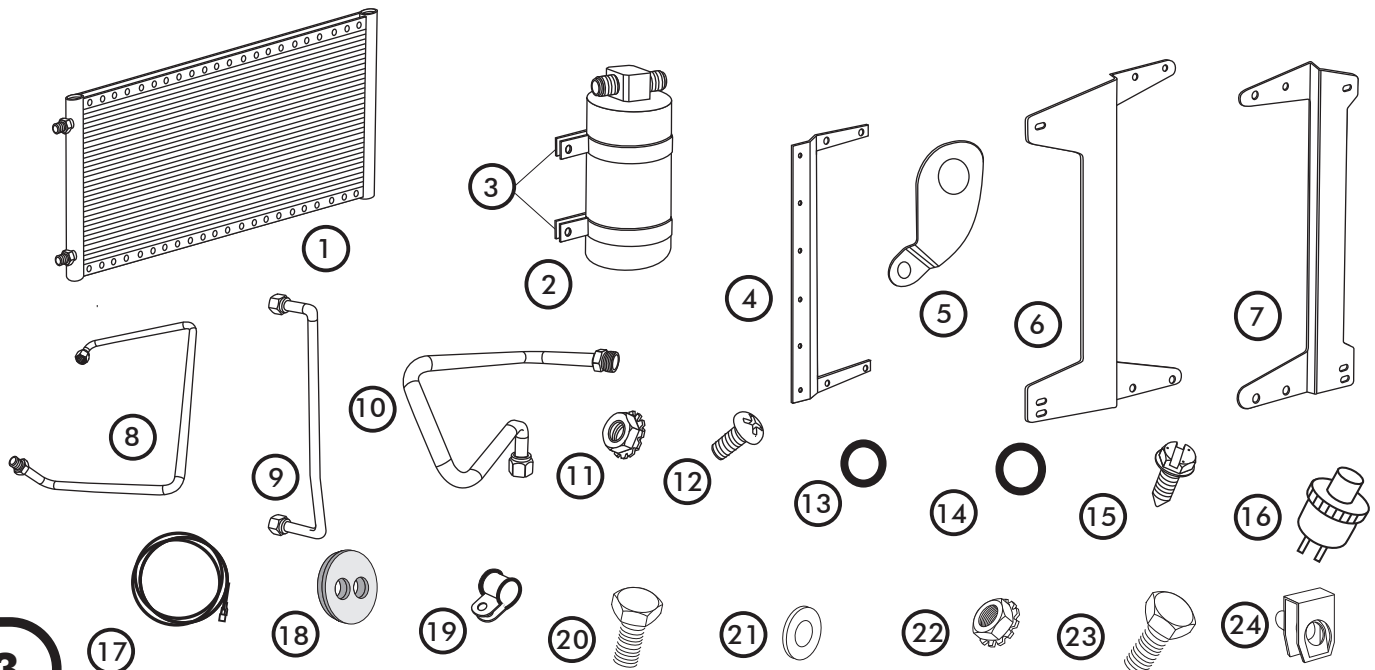



1967-68 MUSTANG

IMPORTANT NOTICE-PLEASE READ

THIS KIT WAS DEVELOPED BASED ON THE MEASUREMENTS BELOW, WHICH WERE TAKEN FROM A 1968 MUSTANG WITH FACTORY AIR CORE SUPPORT.

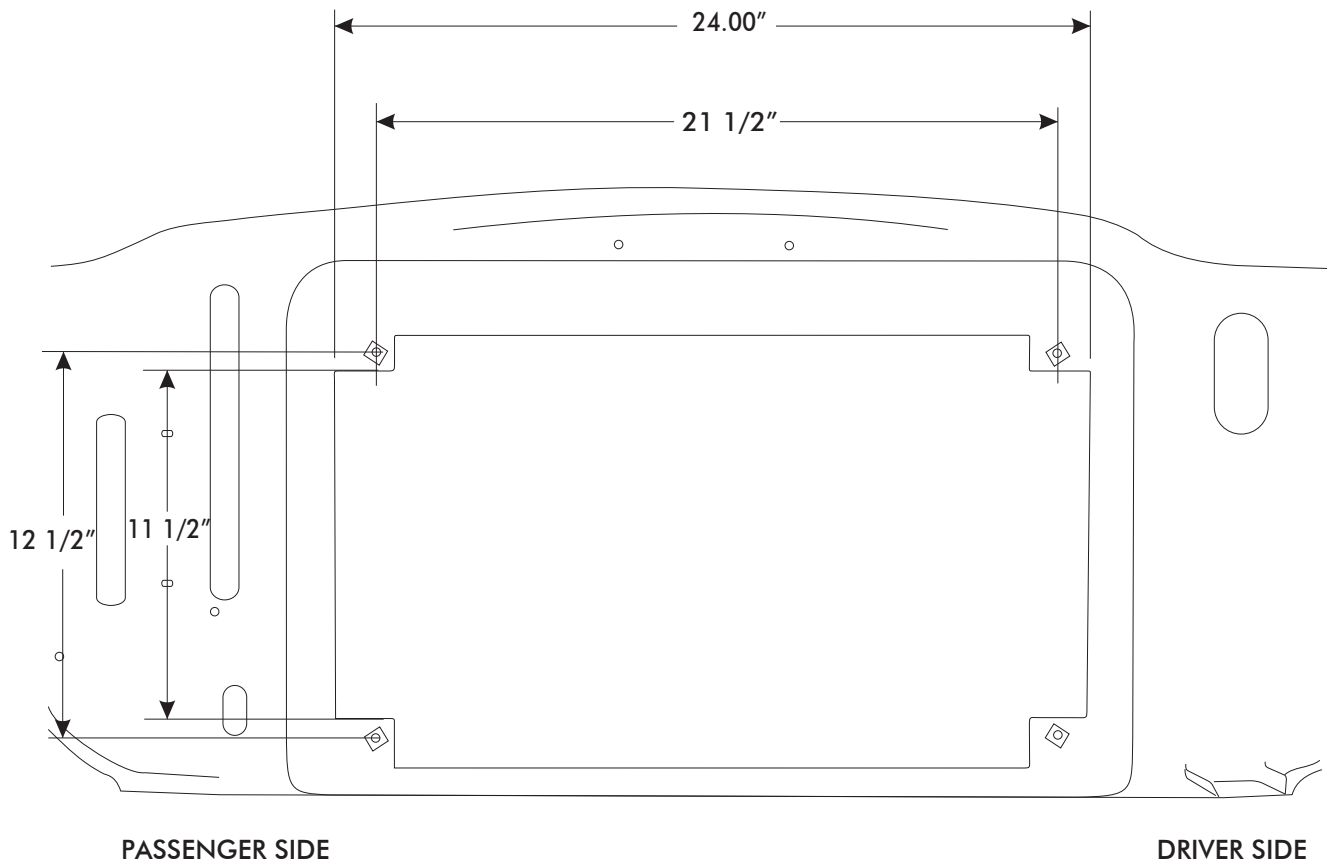



CONDENSER BRACKET INSTALLATION

642069
PS COND
BRKT

1ST & 3RD HOLES

642070
DS COND
BRKT

FRONT VIEW

08164-PFL
#6 COND/DRIER
HARDLINE

07113-VUB
DRIER CLAMP

07321-VUC
2-WAY DRIER

65998-VUB
DRIER BRKT

1ST & 3RD HOLES

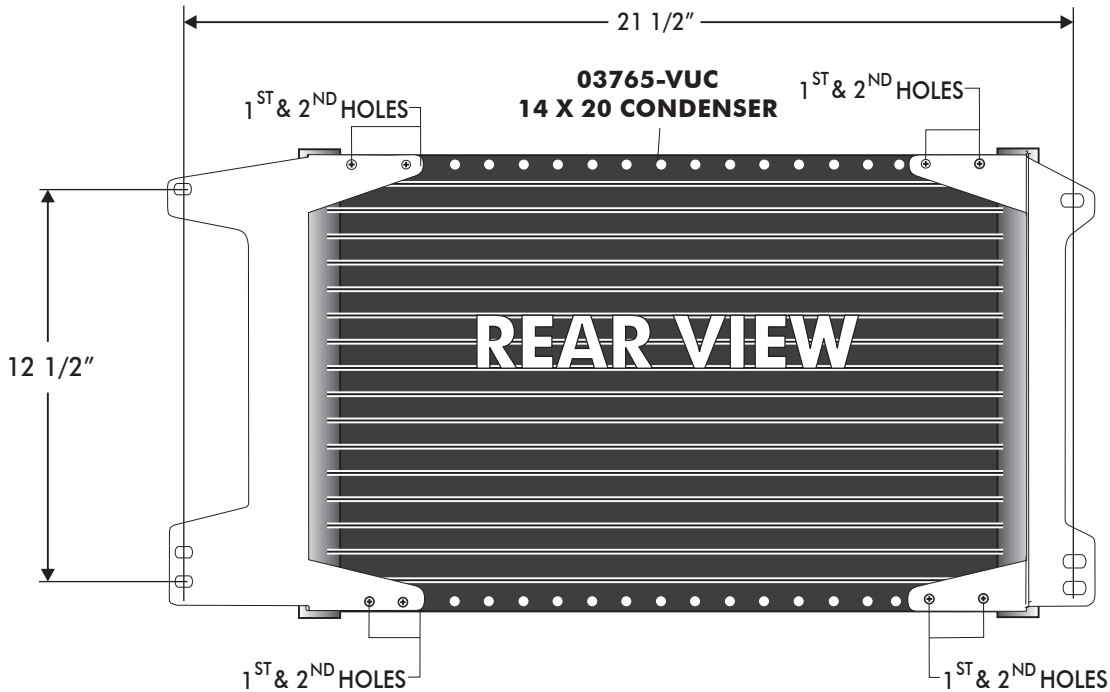



DRIER BRACKET INSTALLATION

ON A WORK BENCH ASSEMBLE CONDENSER AS FOLLOWS:

- INSTALL DRIER MOUNTING BRACKET ON TO CONDENSER USING (4) 10-24 X 3/8 PAN HEAD SCREWS AND (4) 10-24 NUTS WITH STAR WASHERS. SEE FIGURE 1 BELOW. **NOTE: BRACKETS MOUNT THROUGH THE FIRST AND THIRD HOLE IN THE CONDENSER.**

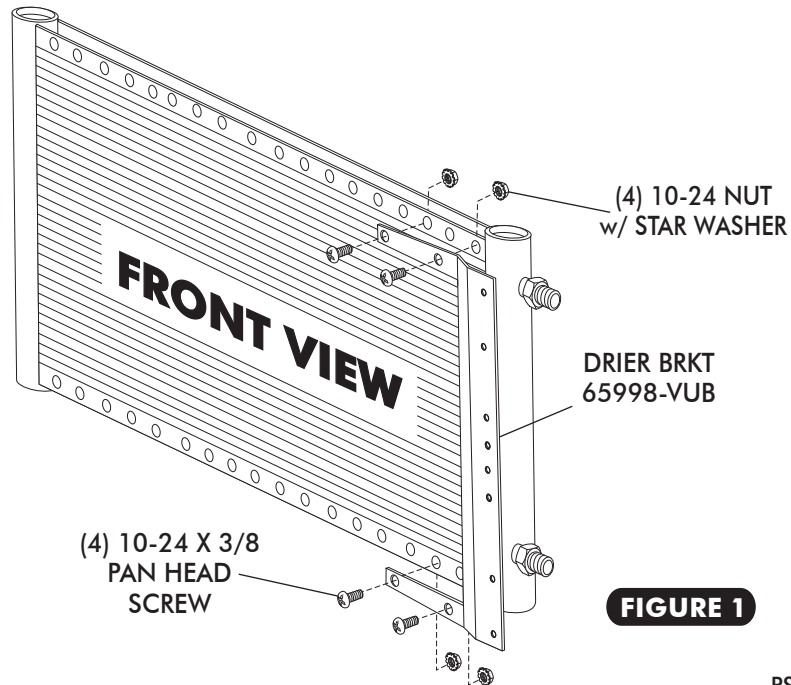

FIGURE 1

MOUNTING BRACKET INSTALLATION

- INSTALL CONDENSER MOUNTING BRACKET ONTO CONDENSER USING (8) 10/24 X 3/8 PAN HEAD SCREWS AND (8) 10/24 NUTS WITH STAR WASHERS. SEE FIGURE 2 BELOW. **NOTE: BRACKETS MOUNT THROUGH THE FIRST AND SECOND HOLE OF THE CONDENSER.**

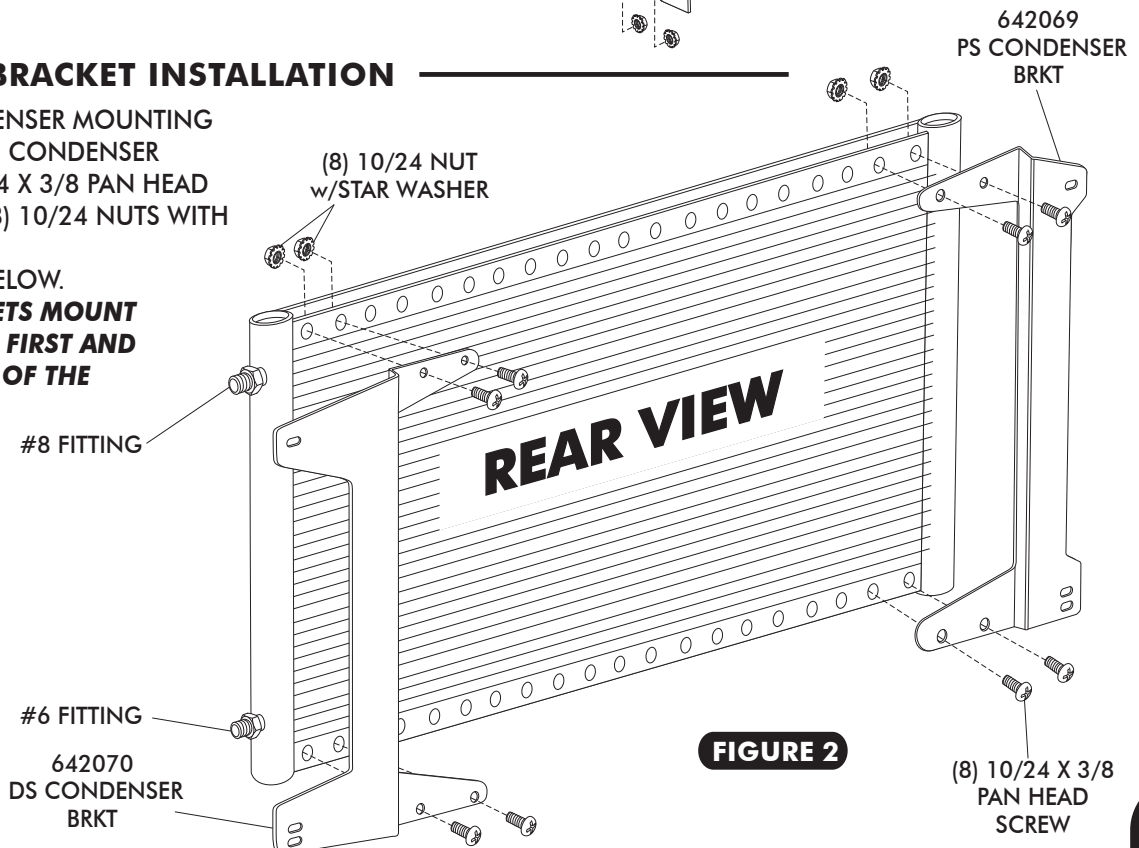

FIGURE 2



DRIER INSTALLATION

- INSTALL DRIER CLAMPS ON DRIER AS SHOWN IN FIGURE 3.
- USING (2) #10 X 1/2 SHEETMETAL SCREWS, INSTALL DRIER ON BRACKET IN THE 6TH AND 7TH HOLES FROM THE BOTTOM OF BRACKET AS SHOWN IN FIGURE 3.

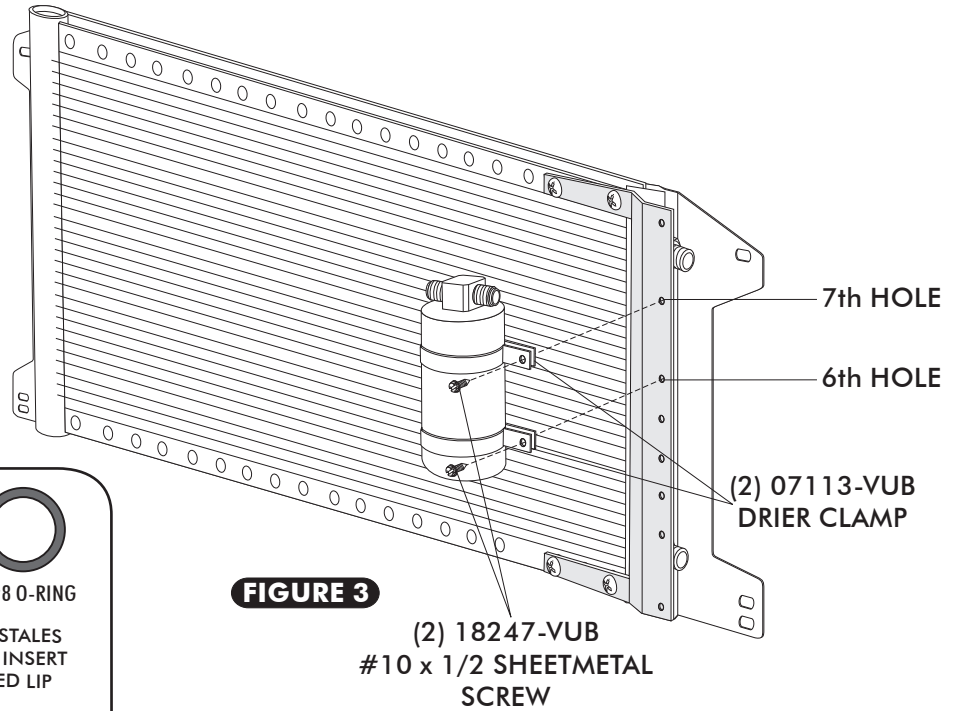

FIGURE 3

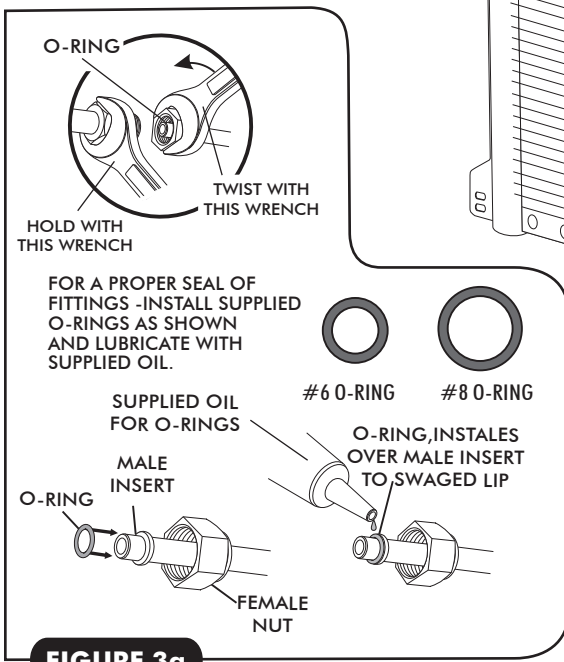

FIGURE 3a

HARDLINE INSTALLATION

- LUBRICATE (2) #6 O-RINGS SEE FIGURE 3a ABOVE, AND INSTALL THE #6 DRIER/COND HARDLINE AS SHOWN IN FIGURE 4. TIGHTEN FITTINGS AS SHOWN IN FIGURE 3a ABOVE.

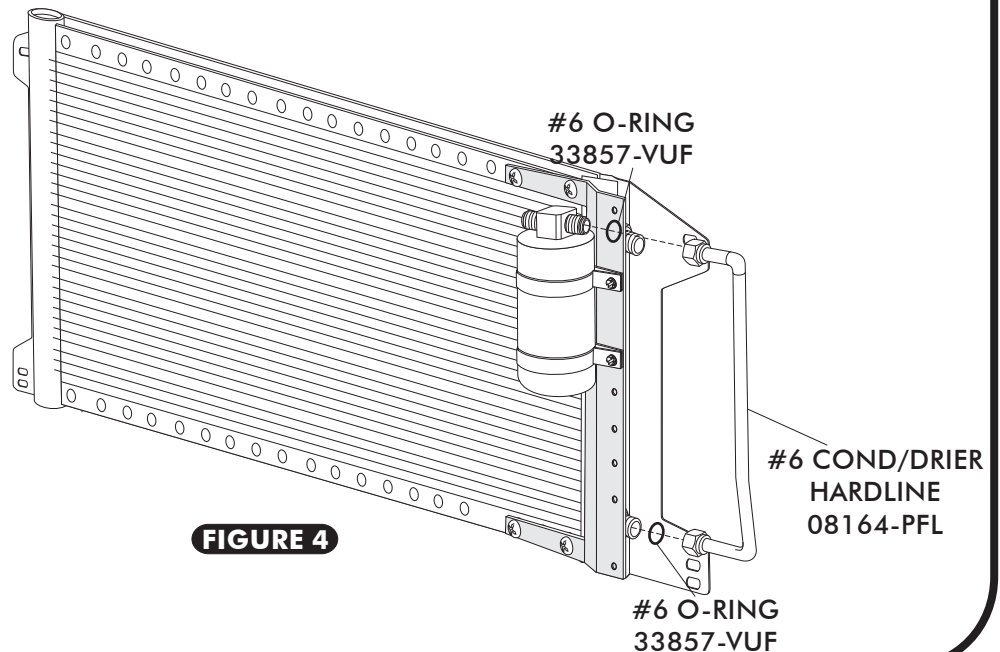

FIGURE 4



RADIATOR REMOVAL

- DRAIN RADIATOR. REMOVE UPPER AND LOWER RADIATOR HOSES. REMOVE RADIATOR.

CORE SUPPORT MODIFICATION

w/AC

- USING TEMPLATE PROVIDED ON PAGE 11, DRILL 1/4" HOLE. SEE FIGURE 5a.
- INSTALL BRACKET ON THE BACK SIDE OF CORE SUPPORT USING 1/4-20 X 1/2 BOLT WITH FLAT WASHERS AND NUT WITH STAR WASHER.
- INSTALL GROMMET ON BRACKET AS SHOWN IN FIGURE 5b.

w/o AC

OPTION 1:

- USING TEMPLATE PROVIDED ON PAGE 11, WELD KNOCK OUT PLATE TO CORE SUPPORT AS SHOWN IN FIGURE 6a.
- DRILL HOLE IN CORE SUPPORT USING A 1 1/4 HOLE SAW.
- INSTALL GROMMET IN HOLE AS SHOWN IN FIGURE 6b.

OPTION 2:

- KNOCK OUT THE PLATE ON THE CORE SUPPORT. USING TEMPLATE PROVIDED ON PAGE 11, DRILL 1/4" HOLE. INSTALL BRACKET ON THE BACK SIDE OF CORE SUPPORT USING 1/4-20 X 1/2 BOLT WITH FLAT WASHERS AND NUT WITH STAR WASHER.
- INSTALL GROMMET ON BRACKET AS SHOWN IN FIGURE 5b.

w/AC

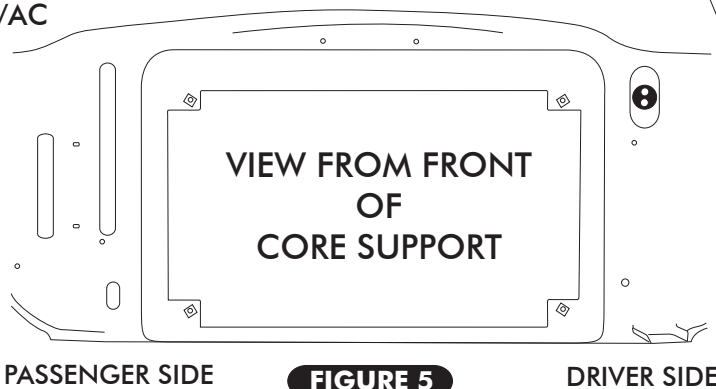

FIGURE 5

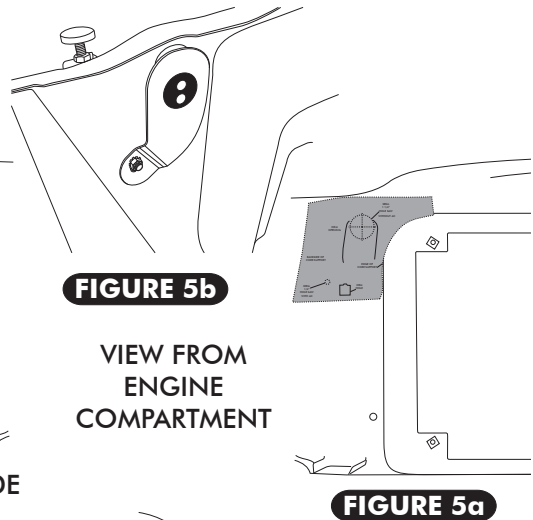

FIGURE 5b

VIEW FROM ENGINE COMPARTMENT

FIGURE 5a

w/o AC

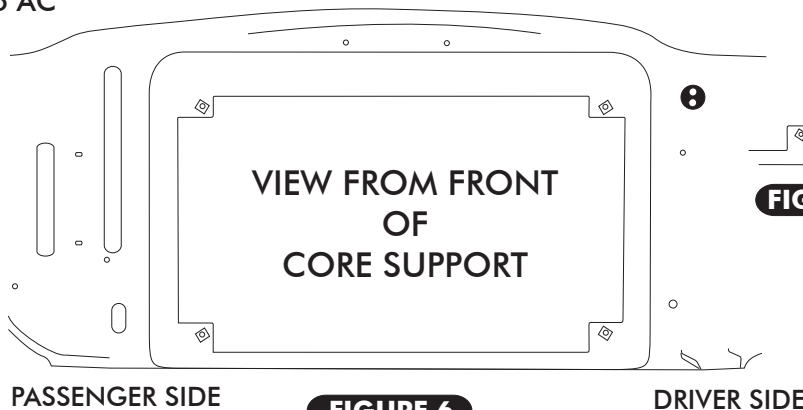

FIGURE 6

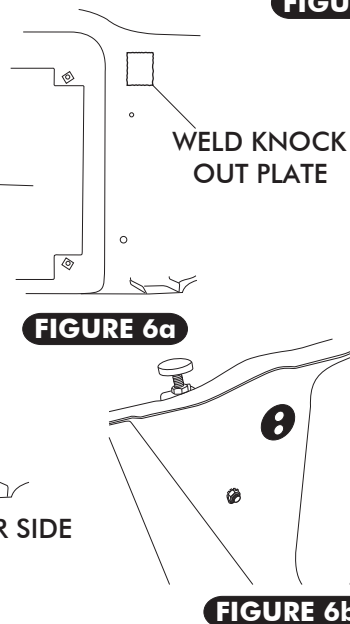

FIGURE 6a

FIGURE 6b



CONDENSER ASSEMBLY AND FAN SHROUD INSTALLATION

- INSTALL (4) 1/4 U-NUTS ON CORE SUPPORT AS SHOWN IN FIGURE 7.
- INSTALL CONDENSER ASSEMBLY BETWEEN THE RADIATOR AND THE CORE SUPPORT AS SHOWN IN FIGURE 7.

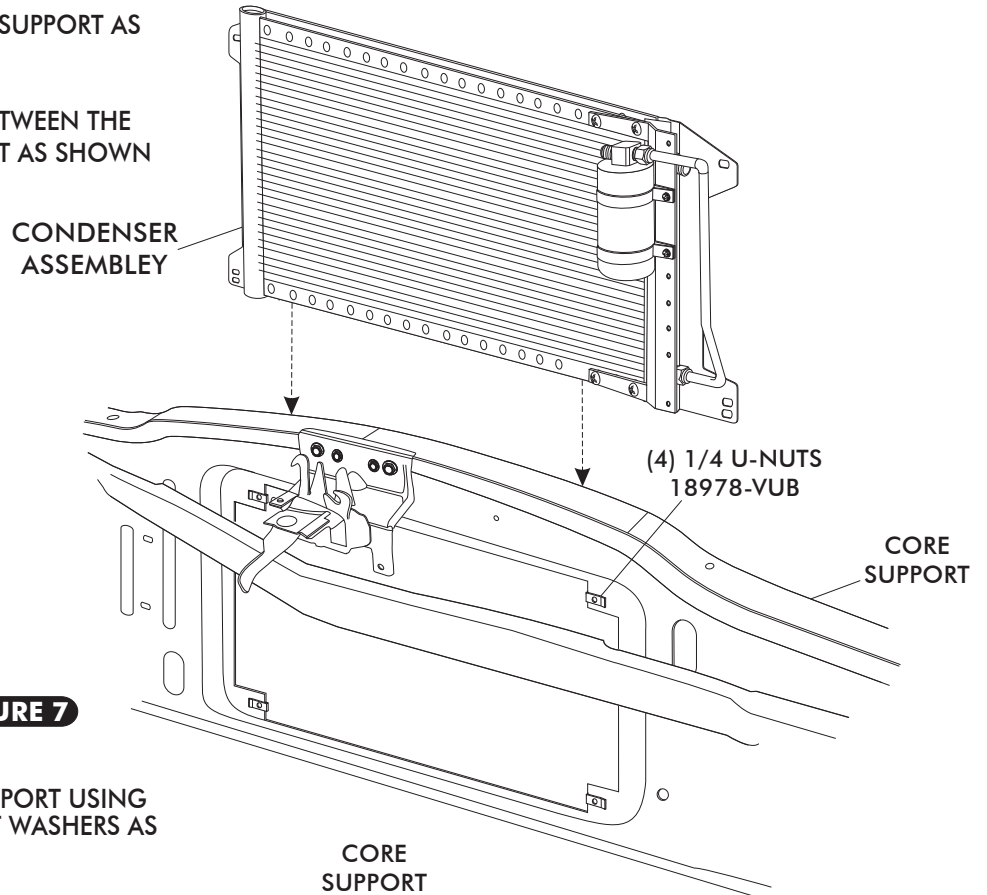

FIGURE 7

- SECURE CONDENSER TO CORE SUPPORT USING (4) 1/4-20 X 1 HEX BOLTS AND FLAT WASHERS AS SHOWN IN FIGURE 8.
- REINSTALL FAN SHROUD AND RADIATOR USING OEM HARDWARE AS SHOWN IN FIGURE 8.

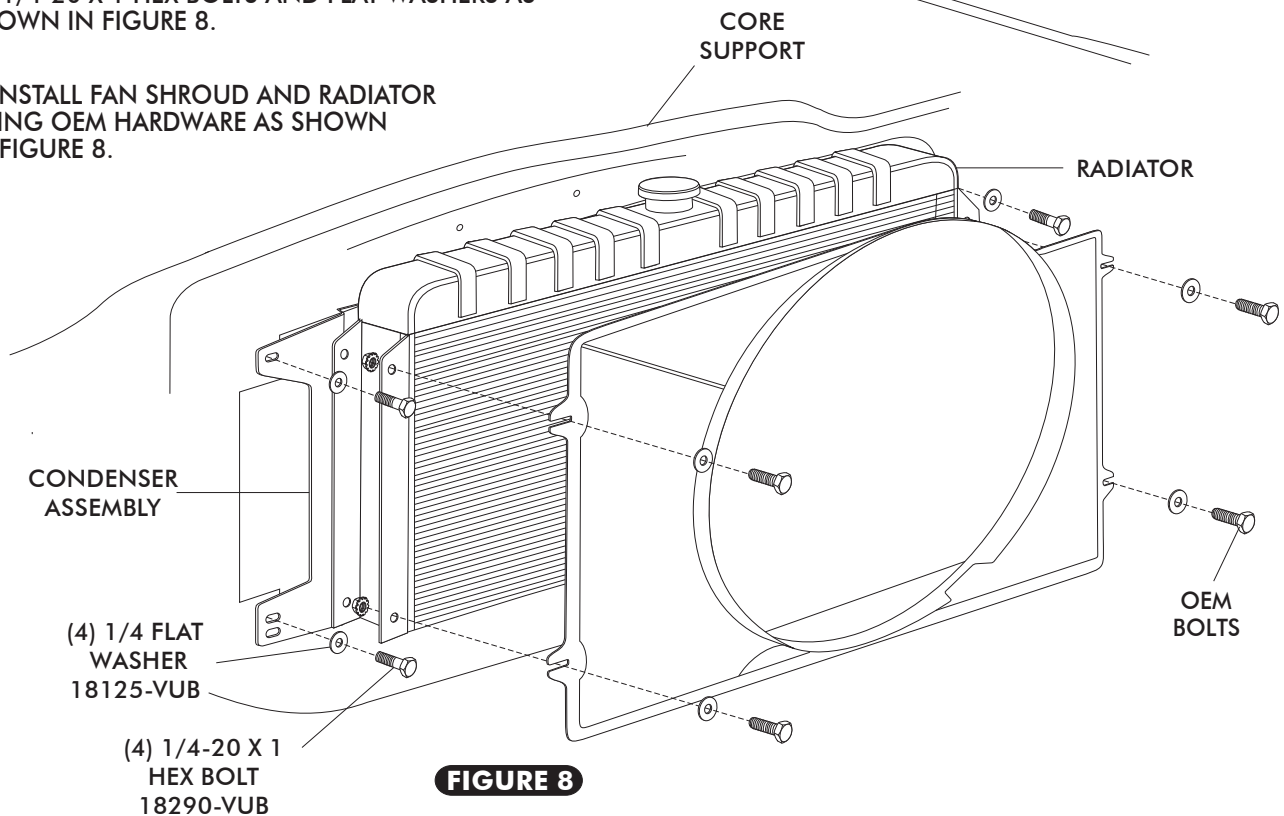
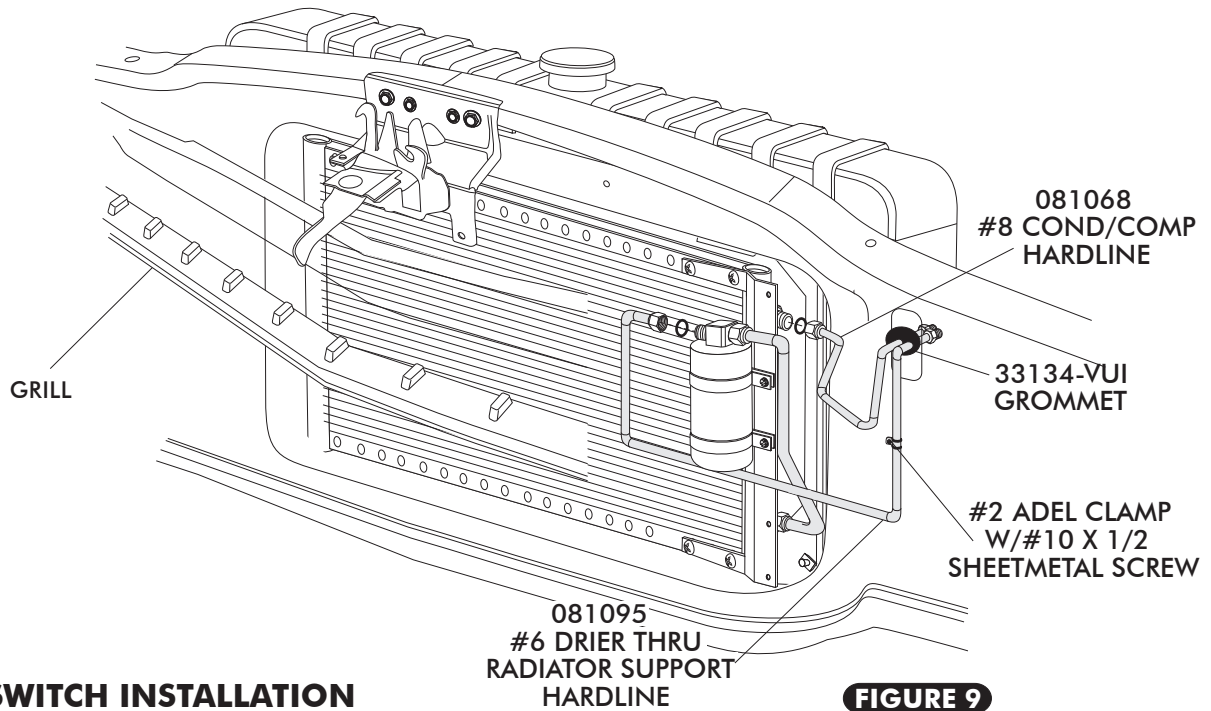

FIGURE 8



HARDLINE INSTALLATION

- LUBRICATE A #6 AND #8 O-RING AS SHOWN IN FIGURE 3a ON PAGE 7. INSTALL THE #6 DRIER HARDLINE AND THE #8 CONDENSER HARDLINE AS SHOWN IN FIGURE 9 BELOW. TIGHTEN FITTINGS AS SHOWN IN FIGURE 3a ON PAGE 7.
SECURE #6 DR/CORE HARDLINE TO RADIATOR CORE SUPPORT W/#2 ADEL CLAMP USING #10 X 1/2 SHEETMETAL SCREW SEE FIGURE 9 BELOW.



BINARY SWITCH INSTALLATION

- INSTALL BINARY SWITCH ON DRIER AS SHOWN IN FIGURE 9a

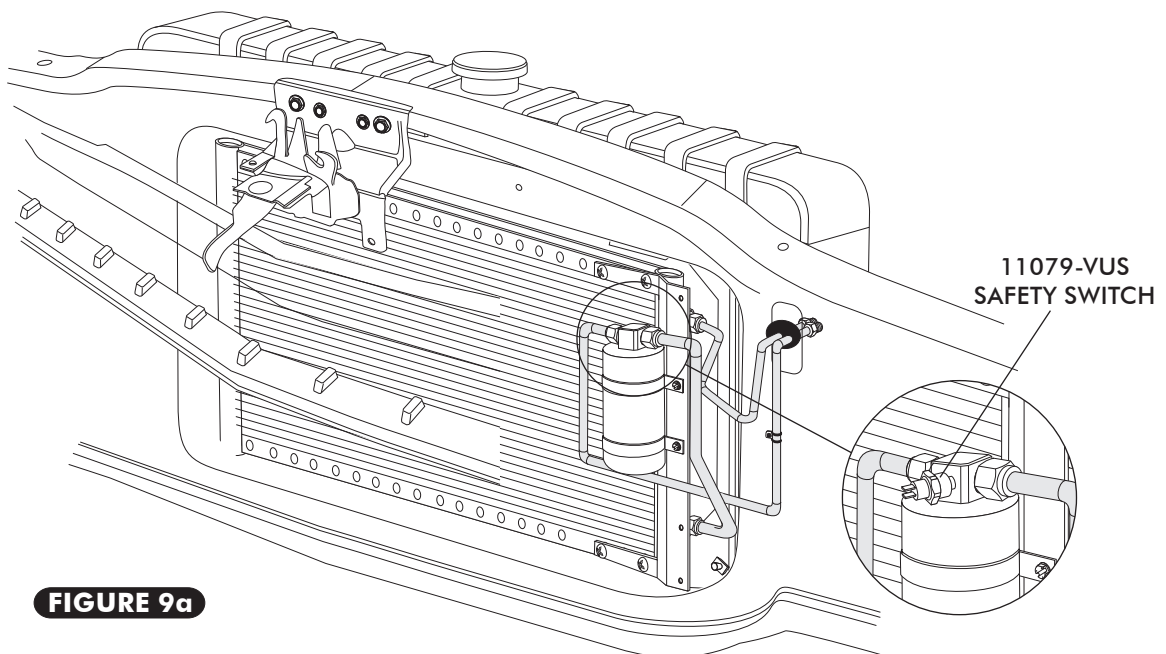



HORN BRACKET MODIFICATION

- CUT OR GRIND HORN BRACKET TAB FOR PROPER LINE CLEARANCE AS SHOWN BELOW IN FIGURE 10.

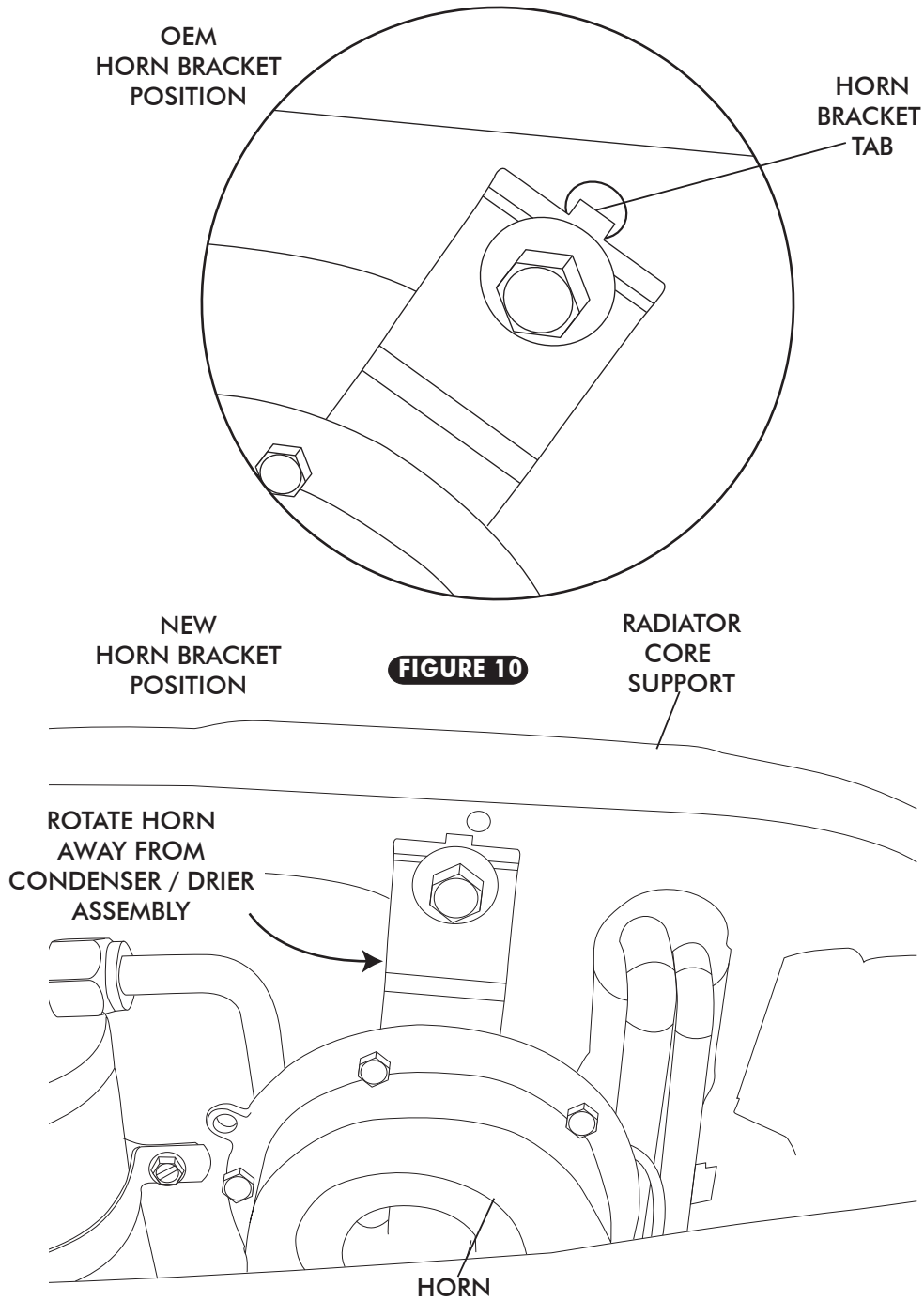



CORE SUPPORT MODIFICATION TEMPLATE

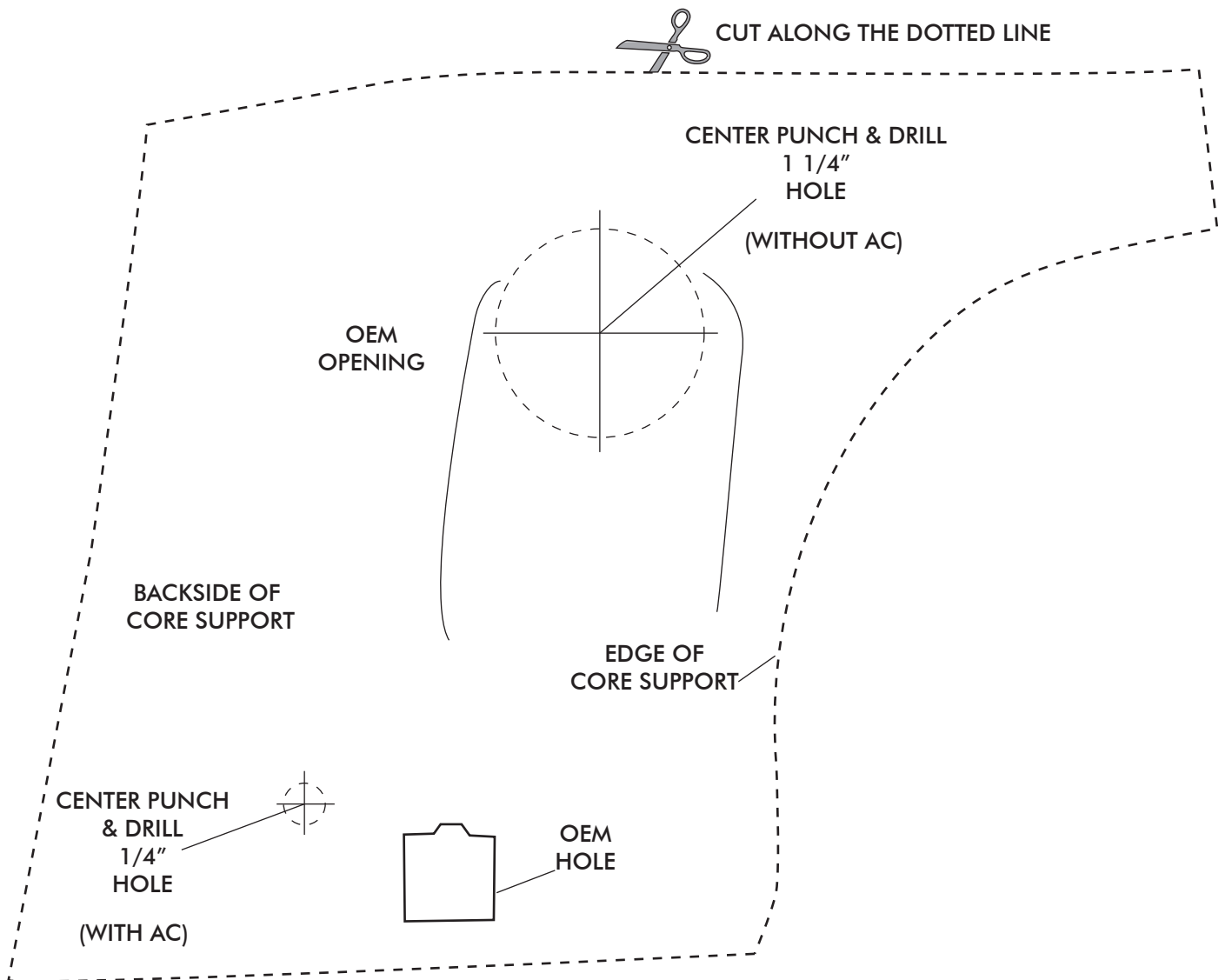



1967-68 MUSTANG CONDENSER WITH DRIER

CONDENSER KIT
011068

No.	QTY.	PART NO.	DESCRIPTION
1.	1	03765-VUC	SUPER FLOW CONDENSER 14 X 20
2.	1	07321-VUC	DRIER
3.	2	07113-VUB	DRIER CLAMP
4.	1	65998-VUB	UNIVERSAL DRIER BRKT 14 3/4
5.	1	642073	67-70 MUSTANG RAD CORE HARDLINE SUPPORT BRKT
6.	1	642070	67-70 MUSTANG DS COND BRKT
7.	1	642069	67-70 MUSTANG PS COND BRKT
8.	1	081095	#6 DR/CORE HARDLINE
9.	1	08164-PFL	#6 DRIER/COND HARDLINE
10.	1	081068	#8 COND HARDLINE
11.	12	18260-VUB	10/24 NUT WITH STAR WASHER
12.	12	18249-VUB	10/24 X 3/8 PAN HEAD SCREW
13.	3	33857-VUF	#6 O-RING
14.	1	33858-VUF	#8 O-RING
15.	3	18247-VUB	#10 X 1/2 SHEETMETAL SCREW
16.	1	11079-VUS	MALE BINARY SWITCH
17.	1	23135-VUW	COMPRESSOR LEAD
18.	1	33134-VUI	GROMMET
19.	1	31600-VUD	#2 ADEL CLAMP
20.	1	18287-VUB	1/4-20 X 1/2 HEX BOLT
21.	5	18125-VUB	1/4 FLAT WASHER
22.	1	18152-VUB	1/4-20 NUT WITH STAR WASHER
23.	4	18290-VUB	1/4-20 X 1 HEX BOLT
24.	4	18978-VUB	1/4 U-NUT

CHECKED BY: _____
 PACKED BY: _____
 DATE: _____

