



Technical Support Line: (952) 985-5675 Email: Info@QA1.net

21730 Hanover Ave.  
Lakeville, MN 55044  
www.QA1.net

**INSTALLATION INSTRUCTIONS**

*QA1 P/N MT100K & MT102K*

*Shock Mount Bracket Kit*

READ ALL INSTRUCTIONS CAREFULLY AND THOROUGHLY PRIOR TO STARTING INSTALLATION. PRODUCTS THAT HAVE BEEN INSTALLED ARE NOT ELIGIBLE FOR RETURN. USE THE PROPER JACKING LOCATIONS. DEATH OR SERIOUS INJURY CAN RESULT IF INSTRUCTIONS ARE NOT CORRECTLY FOLLOWED. A GOOD CHASSIS MANUAL, AVAILABLE AT YOUR LOCAL PARTS STORE, MAY ALSO AID IN YOUR INSTALLATION.

• **DISCLAIMER / WARRANTY** •

QA1 WARRANTS THAT THE PRODUCTS WILL BE FREE FROM DEFECTS IN MATERIAL AND WORKMANSHIP FOR ONE YEAR FROM DATE OF SALE TO THE ORIGINAL PURCHASER. QA1 MAKES NO OTHER WARRANTY OF ANY KIND, EXPRESS OR IMPLIED. QA1 SHALL HAVE NO OBLIGATION UNDER THE FOREGOING WARRANTY WHERE THE DEFECT IS THE RESULT OF IMPROPER OR ABNORMAL USE, YOUR NEGLIGENCE, VEHICLE ACCIDENT, IMPROPER OR INCORRECT INSTALLATION OR MAINTENANCE, NOR WHEN THE PRODUCT HAS BEEN REPAIRED OR ALTERED IN ANY WAY. QA1'S LIABILITY IN THE CASE OF DEFECTIVE PRODUCTS SUBJECT TO THE FOREGOING WARRANTY SHALL BE LIMITED TO THE REPAIR OR REPLACEMENT, AT QA1'S OPTION, OF THE DEFECTIVE PRODUCTS.

THE USER UNDERSTANDS AND RECOGNIZES THAT RACING PARTS, SPECIALIZED STREET ROD EQUIPMENT, AND ALL PARTS AND SERVICES SOLD BY QA1 ARE EXPOSED TO MANY AND VARIED CONDITIONS DUE TO THE MANNER IN WHICH THEY ARE INSTALLED AND USED. QA1 SHALL BEAR NO LIABILITY FOR ANY LOSS, DAMAGE OR INJURY, EITHER TO A PERSON OR TO PROPERTY, RESULTING FROM THE INSTALLATION, DIRECT OR INDIRECT USE OF ANY QA1 PRODUCTS OR INABILITY BY THE BUYER TO DETERMINE PROPER USE OR APPLICATION OF QA1 PRODUCTS. WITH THE EXCEPTION OF THE LIMITED LIABILITY WARRANTY SET FORTH ABOVE, QA1 SHALL NOT BE LIABLE FOR ANY CLAIMS, DEMANDS, INJURIES, DAMAGES, ACTIONS, OR CAUSES OF ACTION WHATSOEVER TO BUYER ARISING OUT OF OR CONNECTED WITH THE USE OF ANY QA1 PRODUCTS. MOTORSPORTS ARE DANGEROUS; AS SUCH, NO WARRANTY OR REPRESENTATION IS MADE AS TO THE PRODUCT'S ABILITY TO PROTECT THE USER FROM INJURY OR DEATH. THE USER ASSUMES THAT RISK!

**Parts Included**

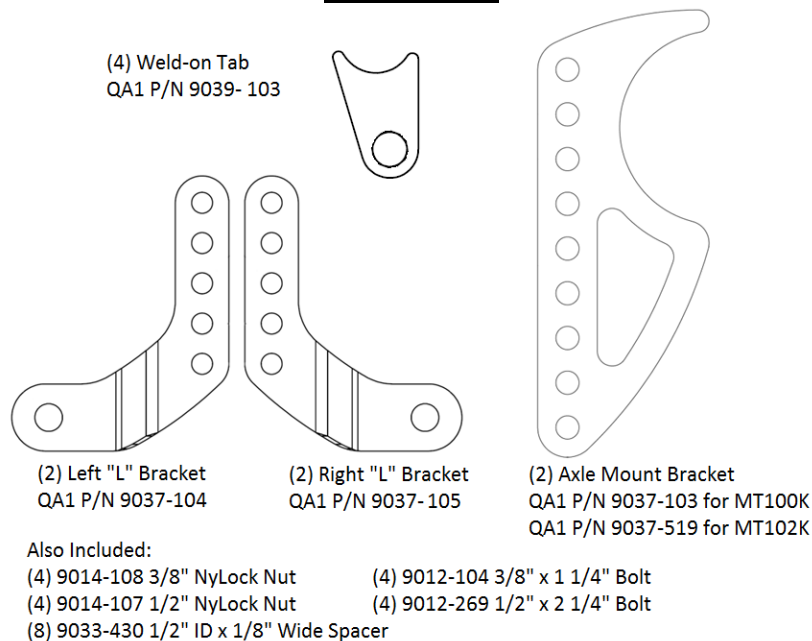

**Warning: This kit does not contain all necessary components to convert from a leaf spring suspension to a link suspension. This kit contains shock mounts only.**

## Installation Instructions

1. With the car sitting at ride height on level ground, measure the chassis ride height at the center of the wheel opening or at the rocker panel and record this measurement for both sides of the car.
2. Remove the coil springs. If the car is equipped with leaf springs, leave them in place to locate the axle. They locate the rear from side to side and front to rear. Use a floor jack to lift the rear of the car back to the chassis ride height measurement that was taken earlier. It is recommended to tack weld a piece of scrap metal to the rear end housing and frame rail. This jigs the rear end housing into the proper chassis ride height.
3. If the vehicle has factory frame rails, it is recommended that the frame rails be double plated in the area the cross member is to be welded. Keep in mind that the upper points should be as parallel to each other as possible (See **Figure 1**). Measure the distance from frame rail to frame rail and cut the cross member tubing to length (if applicable). Tack the tubing into place. Double check all measurements.
4. Assemble both sets of upper mounts (two tabs, one  $\frac{1}{2}$ " ID x  $1\frac{1}{4}$ " in. wide sleeve or a 1" wide bearing (from shock), one  $\frac{1}{2}$ " x  $2\frac{1}{2}$ " bolt and one  $\frac{1}{2}$ " nut). Assemble both of the adjustable mounts (one left L-bracket, one Right L-bracket, one housing bracket, two  $\frac{3}{8}$ " x  $1\frac{1}{4}$ " bolts, two  $\frac{3}{8}$ " nuts). When assembling the adjustable shock mount brackets, the housing bracket is sandwiched between the two L-brackets. Align the L-brackets so the shock mount hole is approximately halfway down the housing bracket (**Figure 1**). This allows plenty of ride height adjustment, both up and down. It is suggested that for the installation process you substitute the lock nuts with standard nuts for ease of use.
5. Now with the cross member located, you will need to locate the positions of the upper shock mounting tabs and the housing brackets. An easy way of accomplishing this is to use a plumb bob (a nut tied to a string will also work). Wrap string around the center of the sleeve between the two tabs, from that point let the end of the plumb bob extend to 14" to  $14\frac{1}{2}$ ". Hold the upper shock mount assembly against the upper cross member and move it from side to side to find the best location for it and the adjustable shock mount on the rear axle housing. Once the best left and right position for both is found, rotate the upper mount up and down until the plumb bob pointer lines up with the shock bolt in the adjustable mount. This will provide the proper shock ride height distance. Once the location is found, tack weld the upper mount to the cross member. Tack the adjustable mount into place on the axle housing. Repeat the procedure on the other side. Make sure that both housing brackets are set in from the frame rail or housing ends as close to the same distance as possible. Make sure to double check all measurements to ensure everything is square.
6. Grind or break the tack welds on the cross member at the frame rails and remove it from the car for finish welding. It is only necessary to weld on the outsides of the tabs. Welding both sides of the tabs may cause weakness in the weld joint from embrittlement. Tie the plumb bobs back onto the upper shock sleeves as before. Put the cross member back in place under the car and realign your plumb bobs over the lower shock mounts. Weld all the way around both ends of the upper cross member. Remove the L-brackets from the housing brackets. Make sure the housing brackets are straight and square with the housing. Finish weld the brackets to the housing.
7. If converting from leaf springs, additional components are required to locate the axle front to rear and side to side such as ladder bars or a four link which are available from many quality companies. If a custom system is being designed, QA1 does offer rod ends, jam nuts and threaded tube adaptors.
8. Remove the nuts, bolts and sleeves from the upper mounts. Put the L-brackets back onto the housing brackets in the original position. If not already installed, push all four sleeves into the bushings at the ends of each shock by hand or with a vice. Next install the springs on the shocks according to the instructions included with your shock. Place the floor jack under the rear end housing, just touching it. Remove the scrap piece being used as your ride height jig at this time. Lower the housing to install the shocks in the mounts.
9. Reinstall; the fuel tank, fuel and brake lines. Check for any interference.
10. It will be necessary to adjust the spring seat to achieve the proper shock ride height. The shock ride height is measured from the center of the upper shock eye to the center of the lower shock eye with the car sitting on the ground at ride height. (**Figure 1**). The shock ride height should be 14" to  $14\frac{1}{2}$ " if you have purchased a QA1 Pro-Rear System. If the chassis ride height is off some, do not be concerned at this point as it can be changed later. If the shock ride height is

not correct, raise the car and place on jack stands. Let the rear axle hang and adjust the spring seats as needed. Lower the car back to the ground and recheck the shock ride height. If that measures OK, then check your chassis ride height. If the chassis ride height is off, then jack the car back up and put it back on the jack stands. Larger ride height adjustments can be made by moving the brackets up or down on the axle mounts.

11. Reinstall all nuts and bolts and tighten properly. Be sure to use lock nuts upon your final adjustment. Put the car back on the ground and recheck the chassis ride height.

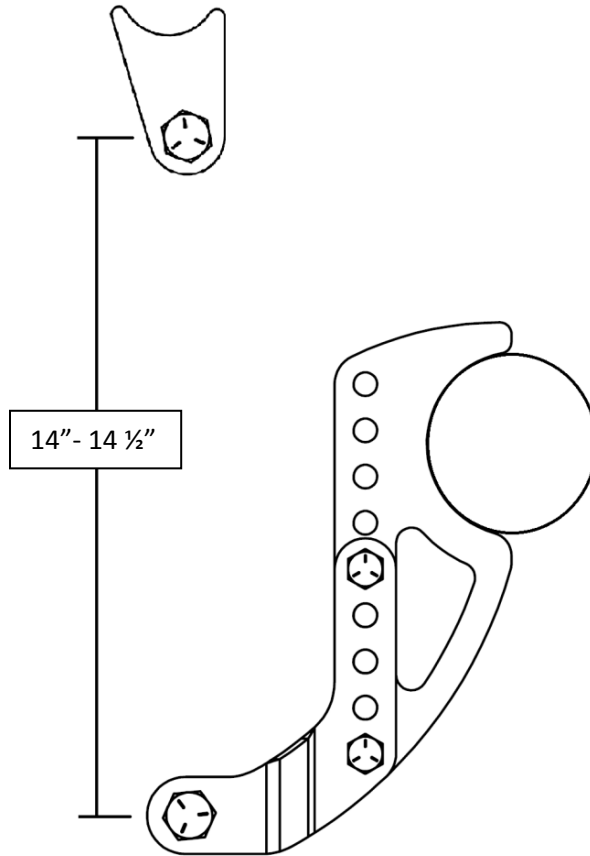

Figure 1

### Dedicated Technical Support Team

QA1 is dedicated to providing quality support and instructions. We employ passionate racers and car enthusiasts that know our products and the industry to better serve you.

Give our tech support line a call at **1.800.721.7761**

Visit online at [www.QA1.net/tech](http://www.QA1.net/tech) or [www.YouTube.com/QA1Tech](http://www.YouTube.com/QA1Tech) for:

- Frequently Asked Questions
- Quick Tips
- Install Information
- Tuning and Repair Guides
- Other Technical Information

Our technical support and order lines are open **Monday – Friday, 8 am to 5 pm CST.**

