

INSTALLATION INSTRUCTIONS

MSD Pro-Power HVC Coil PN 8251

ONLINE PRODUCT REGISTRATION: Register your MSD product online and you'll be entered in our monthly 8.5mm Super Conductor Spark Plug Wire give-away! Registering your product will help if there is ever a warranty issue with your product and helps the MSD R&D team create new products that you ask for! Go to www.msperformance.com/registration.

Parts Included

1 - Pro-Power HVC Coil	2 - Rings Lug Terminals
4 - Vibration Mounts	2 - Nuts & Washers
1 - 2-Pin Weathertight Connector and Harness	2 - 45° Blade Terminals
1 - 2-Pin Weathertight Connector Assembly	2 - Spade Terminals
1 - 4" Black Wire	2- Star Washers

WARNING: Disconnect the battery during installation. When disconnecting the battery, always remove the negative cable first and install it last.

WARNING: Very high voltages are present at the coil when the engine is running. Never connect any test equipment or touch the coil while the engine is running.

The Pro-Power HVC Coil is designed to be used with an MSD 7, 8 or 10 Series Ignition Control only.

INSTALLATION

1. The Coil can be mounted in any position, but should be away from direct heat sources. Use the Coil as a template and mark the location of the mounting holes. Use an 1/8" bit to drill the holes.
2. Install the supplied vibration mounts to the coil and install the coil. Also install one end of the 4" Black wire between a vibration mount and the bracket. Connect the other end to ground.

Note: The supplied star washers must be used on both sides of the ground wire ring lug terminal. This ensures proper grounding through the anodized brackets.

3. The MSD Orange wire connects to coil positive(+). Black connects to coil negative (-). There are two options when connecting the coil:
 - Use the supplied 45° Blade terminals to connect the MSD Ignition wiring.
 - OR
 - Install the supplied 2-pin harness and connect the matching 2-pin connector to the ignition's wiring.
4. Connect the coil secondary wire to the coil and distributor cap.

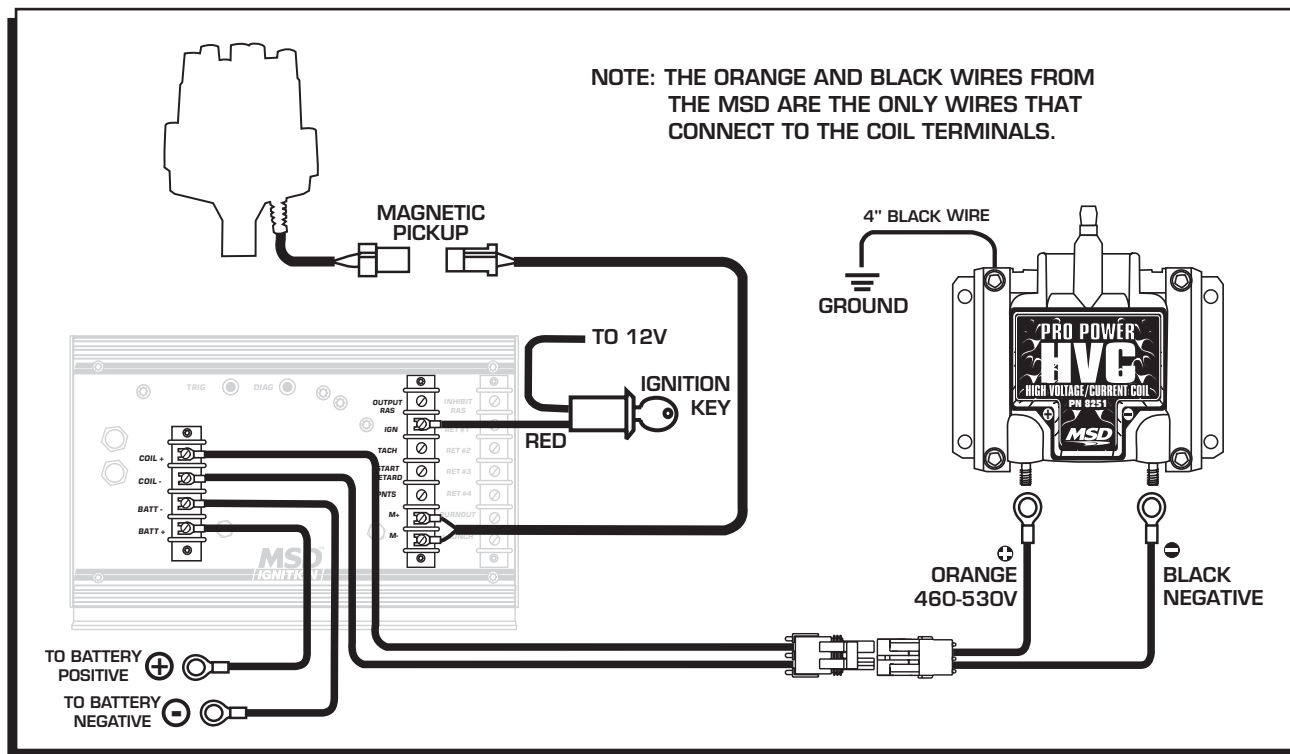

Wiring to an MSD 7AL-3

Service

In case of malfunction, this MSD component will be repaired free of charge according to the terms of the warranty. When returning MSD components for warranty service, **Proof of Purchase** must be supplied for verification. After the warranty period has expired, repair service is based on a minimum and maximum fee.

All returns must have a Return Material Authorization (RMA) number issued to them before being returned. To obtain an RMA number please contact MSD Customer Service at 1 (888) MSD-7859 or visit our website at www.msdpower.com/rma to automatically obtain a number and shipping information.

When returning the unit for repair, leave all wires at the length in which you have them installed. Be sure to include a detailed account of any problems experienced, and what components and accessories are installed on the vehicle. The repaired unit will be returned as soon as possible using Ground shipping methods (ground shipping is covered by warranty). For more information, call MSD at (915) 855-7123. MSD technicians are available from 7:00 a.m. to 5:00 p.m. Monday - Friday (mountain time).

Limited Warranty

MSD warrants this product to be free from defects in material and workmanship under its intended normal use*, when properly installed and purchased from an authorized MSD dealer, for a period of one year from the date of the original purchase. This warranty is void for any products purchased through auction websites. If found to be defective as mentioned above, it will be repaired or replaced at the option of MSD. Any item that is covered under this warranty will be returned free of charge using Ground shipping methods.

This shall constitute the sole remedy of the purchaser and the sole liability of MSD. To the extent permitted by law, the foregoing is exclusive and in lieu of all other warranties or representation whether expressed or implied, including any implied warranty of merchantability or fitness. In no event shall MSD or its suppliers be liable for special or consequential damages.

*Intended normal use means that this item is being used as was originally intended and for the original application as sold by MSD. Any modifications to this item or if it is used on an application other than what MSD markets the product, the warranty will be void. It is the sole responsibility of the customer to determine that this item will work for the application they are intending. MSD will accept no liability for custom applications.