



QUALITY... PLAIN & SIMPLE®

Throttle Pedal Assembly Installation Instructions

For 1955-57 Chevy, 1967-69 Camaro/Firebird, 1964-67 Chevelle, and 1968-72 Nova

General Installation Notes:

Please read instructions completely before beginning installation. If you have any questions please call.

Before starting installation, scotch vehicle tires to avoid accidental movement of the vehicle. Do not attempt to install this product while the engine is running. Disconnect negative battery cable before beginning installation.

Make sure the engine, transmission, body and frame are properly grounded. We recommend applying anti-seize lubricant to all aluminum threads before final assembly.

IMPORTANT APPLICATION INFORMATION: This throttle pedal is designed to replace rod style throttle linkage only. It will not fit a vehicle that originally came with cable style throttle linkage from the factory.

The Lokar pedal assembly is designed for use with Lokar Throttle Cables. Stock style cables will not work. If your vehicle has an automatic transmission, installation of a Lokar Kickdown Kit (if applicable) is strongly recommended. Lokar throttle cables and kickdown kits are application-specific according to the type of induction system and the transmission model.

1955-1957 Chevrolet with big block OR small block with tall valve covers: Lokar has throttle pedals available with a longer billet upper arm (6-7/16" overall length) to prevent interference between the engine and the throttle cable.

Refer to Fig. 1 for the component names.

Step 1: Remove any existing throttle pedal assembly and linkage components.

Step 2: Disassemble the Lokar Throttle Pedal Assembly by removing the 1/4"-20 x 1/2" flat head bolt (Fig. 2, #1) from the end of the mounting shaft (Fig. 2, #14) and sliding the billet lower and upper arms off of the mounting shaft.

Step 3: Install the mounting shaft into the firewall from the engine compartment side using the stock hole where the original throttle linkage was mounted. Use the original bolts to attach it to the firewall. Fig. 3

Step 4: Reassemble the Lokar throttle pedal with the billet lower arm (Fig. 2, #5) pointing down and the billet upper arm (Fig. 2, #6) pointing up. The billet upper and lower arms can be switched left to right if needed for clearance purposes.

Step 5: Push the billet upper arm forward so that it is parallel to the firewall. Mark the firewall in line with the 3/16" hole on the end of the billet upper arm. Drill a 5/16" diameter hole through the firewall for the Lokar throttle cable fitting to mount into. **Note:** On 1955-57 Chevys, the two offset firewall washers (Fig. 2, #15) will have to be installed on the firewall (one inside and one outside) and rotated to allow the throttle cable to go straight through the firewall.

Throttle Pedal Assembly Installation Instructions

For 1955-57 Chevy, 1967-69 Camaro/Firebird, 1964-67 Chevelle, and 1968-72 Nova

Building American Quality... With A Lifetime Warranty!®

10924 Murdock Dr. • Knoxville, TN 37932

TOLL FREE 1-877-469-7440 • (865) 966-2269 • FAX (865) 671-1999 • tech@lokar.com • www.lokar.com

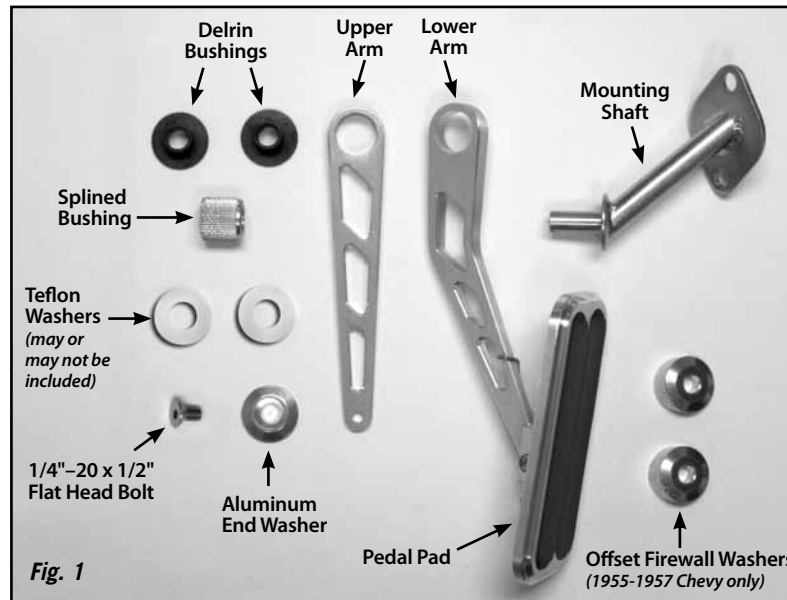
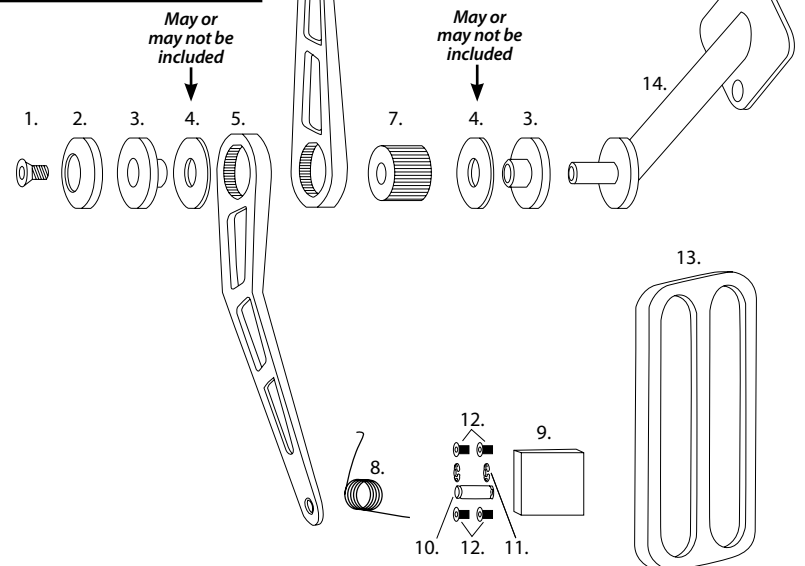

Fig. 1

1. 1/4"-20 x 1/2" Flat Head Bolt
2. Aluminum End Washer
3. Delrin Bushing
4. Teflon Washer (May or may not be included)
5. Billet Lower Arm
6. Billet Upper Arm
7. Splined Bushing
8. Stainless Pedal Pad Spring
9. Gas Pedal Back
10. Stainless Pedal Pad Pin
11. 3/16" Stainless E-Clips
12. #8-32 x 3/16" Button Head Bolt
13. Pedal Pad
14. Mounting Shaft
15. Offset Firewall Washers (55-57 Chevy only)

Fig. 2



Step 6: Install the Lokar throttle cable assembly according to instructions supplied with the throttle cable. You may have to reposition the billet upper arm on the throttle pedal assembly in order to get the throttle cable adjusted correctly. Make sure there is no binding in the throttle linkage and that the throttle returns to the closed position when the pedal is released.

See Fig. 4, 5 and 6 for a finished installation.

NOTE: Once the throttle cable is installed, make sure that the throttle pedal is completely floored when the throttle is wide open. If the throttle pedal is not completely floored at wide open throttle, you will need to either change the position of the billet lower arm on the throttle pedal assembly or install a pedal stop.



QUALITY... PLAIN & SIMPLE®

Throttle Pedal Assembly Installation Instructions

For 1955-57 Chevy, 1967-69 Camaro/Firebird, 1964-67 Chevelle,
and 1968-72 Nova

Throttle Pedal Assembly Installation Instructions

For 1955-57 Chevy, 1967-69 Camaro/Firebird, 1964-67 Chevelle, and 1968-72 Nova

Building American Quality... With A Lifetime Warranty!®

10924 Murdock Dr. • Knoxville, TN 37932

TOLL FREE 1-877-469-7440 • (865) 966-2269 • FAX (865) 671-1999 • tech@lokar.com • www.lokar.com

Mounting Shaft Installation

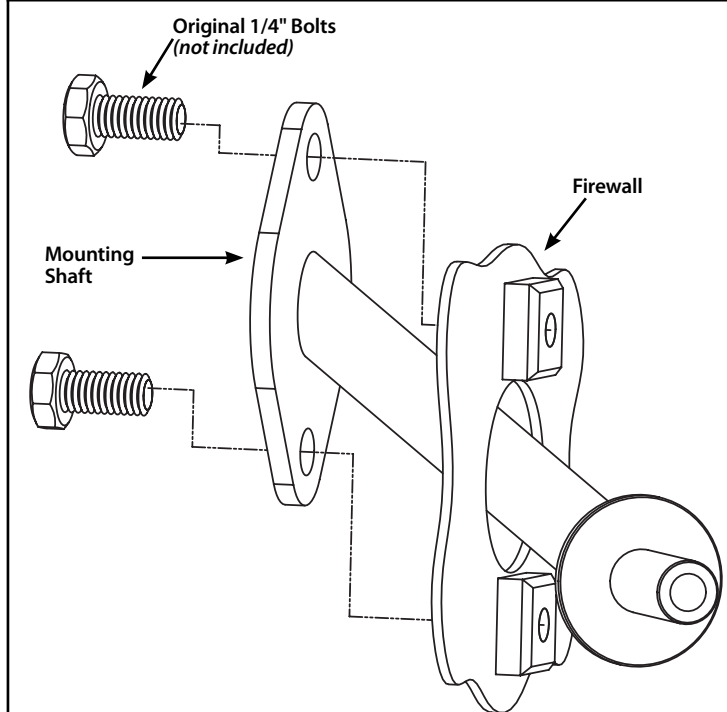

Fig. 3

Inside Passenger Compartment



Engine Side of Firewall



Final Installation

