



# INSTALLATION INSTRUCTIONS

## PART NUMBER: RK-3910-1

**This Assembly Fits:**

SEE CATALOG FOR CURRENT APPLICATIONS

Congratulations, you have purchased the finest custom air cleaner that money can buy. With proper care, this filter will last 1 million miles or more. This custom air cleaner replaces the stock air cleaner assembly. The following procedure **MUST** be followed to ensure a proper fit and seal of the custom air cleaner.

**TOOLS NEEDED:**

- Ratchet
- Extension
- 7/16" Socket
- 5/16" Hex Key Wrench
- 3/32" Hex Key Wrench
- 3/16" Hex Key Wrench
- T27 Torx
- Drill
- 1/2" Drill Bit

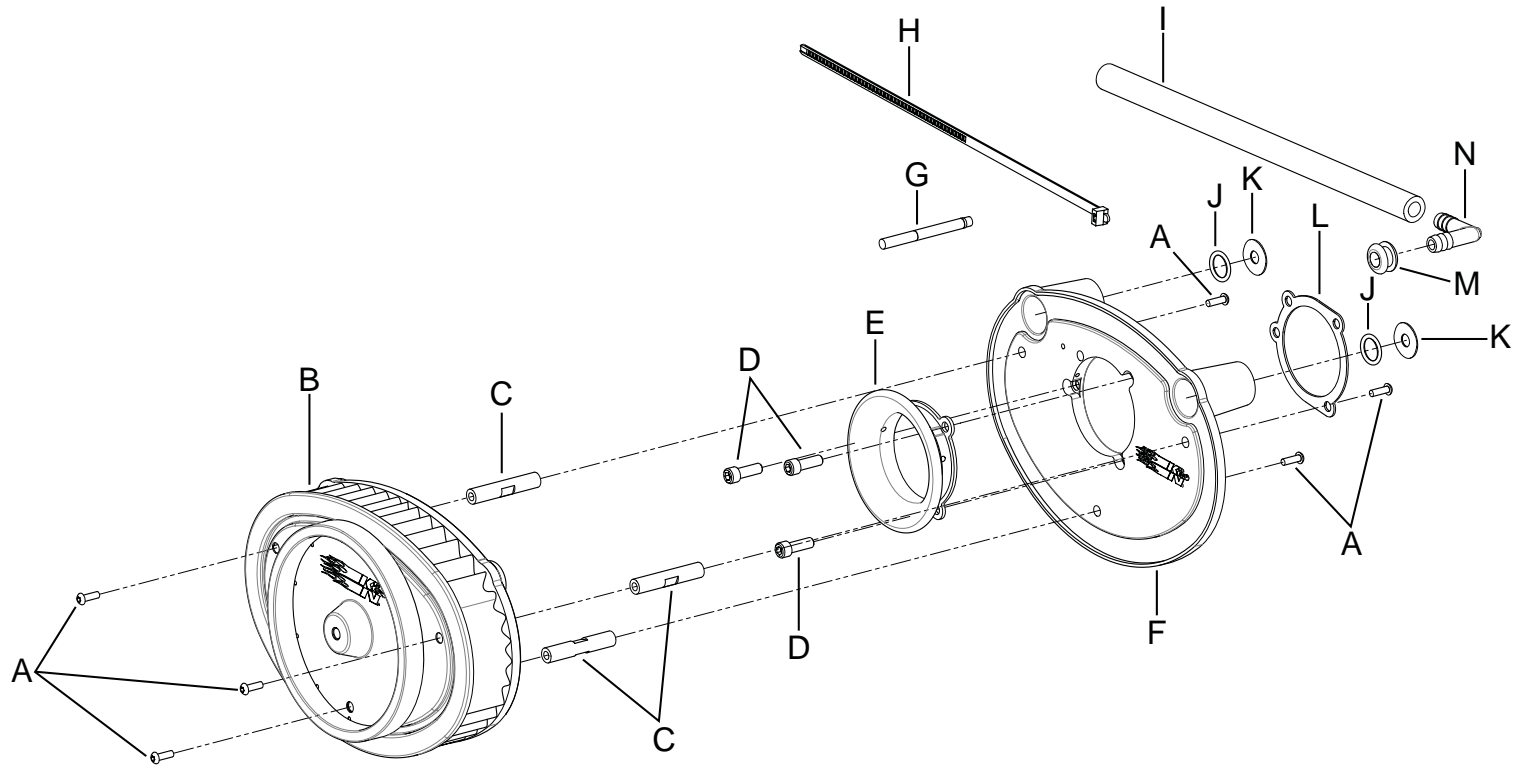

**PARTS LIST:**

| Description                                     | Qty. | Part #  | Description                                      | Qty. | Part # |
|---|------|---------|--|------|--------|
| A Bolt; 1/4-20 X 1/2 Button Sockets, SS         | 6    | 07706   | H Cable Ties; 11" Black                          | 1    | 21590  |
| B Filter Element                                | 1    | E-3980  | I Hose; 3/8" ID X 12"L                           | 1    | 08412  |
| C Spacer, 0.375" OD X 0.25" ID X 2.0" L, 1/4-20 | 3    | 06500-1 | J O-Ring; 9/16" ID, .10 Thick                    | 2    | 07761  |
| D Screw; 1/4-20 X 3/4 SOC. HD. Cap Screw, SS    | 3    | 07731   | K Washer; 3/8" Flat Washer, SS                   | 2    | 08134  |
| E H/D Velocity Stack                            | 1    | 08922-3 | L Gasket; Keihin Carb                            | 1    | 09267  |
| F Back Plate                                    | 1    | 01947   | M Grommet; 7/8" OD, 3/8"ID, 7/16" THK, 3/16" GAP | 1    | 784638 |
| G 2 ML, Medium Strength, Blue                   | 1    | 482     | N Vent; 90Deg, 3/8 X 3/8, Plastic                | 1    | 08121  |

**NOTE: FAILURE TO FOLLOW INSTALLATION INSTRUCTIONS AND NOT USING THE PROVIDED HARDWARE MAY DAMAGE THE THROTTLE BODY AND ENGINE.**

**TO START:**

1. Turn off the ignition and disconnect the negative battery cable.



2. Remove the bolt that secures the bonnet to the filter assembly and remove the bonnet from the vehicle.

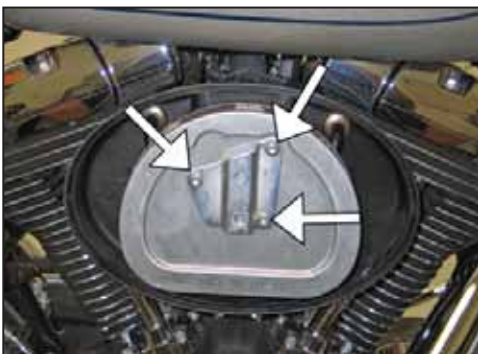

3. Remove the three bolts that secure the air filter to the filter base and remove the air filter along with the crank case breather tubes.



4. Remove the two crank case breather bolts shown.  
**NOTE: These bolts will be reused in a later step.**



5. Remove the air filter base from the throttle body and unhook the wiring pig tail from the filter base.  
**NOTE: K&N Engineering, Inc. recommends that customers do not discard the factory air intake components.**  
**NOTE: Unhook the wiring pigtail from the rear of the filter base. On non-US models, disconnect the intake valve solenoid.**



6. Using the provided tie wrap, secure the wiring pig tail to the throttle body wiring harness.  
**NOTE: On non-US models, a by-pass module (sold separately) will need to be installed onto the pigtail to eliminate an engine management light from turning on. (non-US models only)**



7. On models equipped with an EVAP vent line, cut out the provided template and place it on the filter base plate as shown. Mark the base plate for drilling a 1/2" ID hole.



8. On models equipped with an EVAP vent line, drill a 1/2" id hole in the base plate at the location marked in step #7. Then install the provided grommet and 90° hose mender as shown.



9. Install the venturi and three bolts provided into the filter base plate as shown.

**NOTE: The bolts pass through the base plate and then the venturi on the back side.**



10. Install the three provided spacers onto the base plate as shown.

**NOTE: Place one drop of thread locker onto each bolt.**



11. Install the two provided o-rings onto the base plate as shown.



12. Install the provided gasket onto the base plate as shown.



13. Install the base plate onto the throttle body and then secure with the factory breather bolts and throttle body bolts provided.

**NOTE: Due to manufacturer tolerances, it may be necessary to use one or two of the provided spacers so the base plate seats properly on the throttle body and cylinder heads. Place one drop of thread locker onto each bolts. On models equipped with a EVAP vent line, connect the EVAP line to the 90° hose mender using the provided vent hose, trimming of the vent hose will be necessary.**



14. Install the air filter onto the base plate and secure with the three bolts provided.

**NOTE: Apply one drop of thread locker to each bolt.**



15. Install the filter bonnet onto the air filter and secure with the factory bolt.



16. Reconnect the vehicle's negative battery cable. Double check to make sure everything is tight and properly positioned before starting the vehicle.

17. It will be necessary for all K&N® custom air cleaners to be checked periodically for realignment, clearance and tightening of all connections. Failure to follow the above instructions or proper maintenance may void warranty.

#### ROAD TESTING:

1. Start the engine with the transmission in neutral. Listen for air leaks or odd noises. For air leaks secure hoses and connections. For odd noises, find cause and repair before proceeding. This kit will function identically to the factory system except for being louder and much more responsive.

2. Test ride the vehicle. Listen for odd noises or rattles and fix as necessary.

3. If road test is fine, you can now enjoy the added power and performance from your kit.

4. K&N Engineering, Inc., requires cleaning the intake system's air filter element every 50,000 miles. When used in dusty or off-road environments, our filters will require cleaning more often. We recommend that you visually inspect your filter once every 25,000 miles to determine if the screen is still visible. When the screen is no longer visible some place on the filter element, it is time to clean it. To clean and re-oil, purchase our filter Recharger® service kit, part number 99-5050 or 99-5000 and follow the easy instructions.

Drill Template

