



CAUTION!!! Before installing, please read the following important information....

1. The Ignitor is designed for 12-Volt negative ground systems.
2. Leaving the ignition "ON" with the engine "OFF" for an extended period could result in permanent damage to the Ignitor.
3. **See Chart on back page for coil recommendations.**
4. Four and six cylinder engines require a minimum of 3.0 ohms of primary resistance and eight cylinder engines require a minimum of 1.5 ohms of primary resistance. Do not remove resistors if the coil primary resistance is less than specified.
5. If your Ignition coil has the recommended primary resistance, remove or bypass all external resistors.
6. The Ignitor is compatible as a trigger for most electronic boxes.

DISASSEMBLY

1. **PRIOR TO INSTALLATION TURN IGNITION SWITCH OFF OR DISCONNECT THE BATTERY**
2. Disconnect point wire from negative (-) coil terminal.
3. Remove distributor cap. Do not disconnect spark plug wires from cap. Examine cap for wear or damage. Replace as needed.
4. **REMOVE DISTRIBUTOR FROM ENGINE.** Note position of rotor before removing distributor.
5. Remove rotor. Examine rotor for wear or damage. Replace as needed.
6. Remove point wire from distributor point assembly. Remove points wire from distributor.
7. Remove breaker point assembly and condenser. Retain screws and washers to install Ignitor module.
8. Remove point wire from negative (-) terminal of the coil.
9. The Ignitor does not require any modification to the distributor. Therefore the points, condenser and hardware can be used as backup.
10. Clean all dirt and excess oil from the breaker plate and point cam.

IGNITOR INSTALLATION

11. Install magnet ring by slipping over advance weight assembly and inserting the two threaded 6/32 studs up through the two 10-32 threaded holes where screws that held rotor were removed. (See figures B & C).

IMPORTANT - If you are installing part number 1165, you will find a notch cut in the magnet ring near one of the studs. This stud must be inserted in the hole near the square cutout in the advance weight mechanism.

12. Install rotor (we recommend a new rotor) over the 6/32 studs and secure with 6/32 kep nuts and flat washers. These flat washers are the two thick ones. The thinner spacer washers are furnished for adjusting air gap. Do not tighten these kep nuts at this time.
13. Install Ignitor module in the same holes where the points were. NOTE: Dual point distributors require the module to be mounted in the place of the leading point. Use the screws that held the point assembly to the breaker plate. Screws should be finger tight at this point.

Caution - BE sure that magnet ring is seated against the advance mechanism plate and the module is seated against breaker plate. The shaft must be seated in the lowest position when measuring gap.

14. You will be trying to get an air gap between approximately 0.010" at the low end and no more than 0.060" at the high end. With the distributor shaft pulled down, rotate the shaft and make sure the magnet ring does not rub against the Ignitor module. If it happens to rub against the Ignitor module, carefully bend the Ignitor module bracket down until it does not rub. Bend with pliers at the bracket so as not to loosen the rivets. If there is a gap, rotate the distributor shaft and measure the largest air gap between the face of the magnet ring and the face of the Ignitor module. If you have an Oldsmobile, and the largest gap is more than 0.060", go to step #14. Otherwise, continue with the next step.

15. If the gap is greater than 0.060" record what it is. The gap is adjusted by installing thin washers over the 6/32 studs between the magnet ring and advance mechanism plate. It is necessary to remove module, rotor, and ring to do this. The washers are 0.032" thick. From the gap measurement recorded, Calculate how many washers are needed to bring the lowest part of the magnet ring to approximately 0.010" from the Ignitor module. Install washers on each side. If you have an Oldsmobile, go to step #14. Otherwise, go to the next step.
16. Now push the distributor shaft up and rotate. If the highest point between the Ignitor module and the ring is greater than 0.060", you will need to place shims between the gear and distributor housing to prevent the gap from going over 0.060".
17. Reinstall magnet ring, rotor and module. Secure in position. Double check gap. If readjustment is necessary, follow the above procedure.
18. Instal the rubber grommet from the kits hardware into the large hole on the bottom of the distributor housing.
19. Place both the red and black wires carefully through the grommet.
20. Attach terminals to the ends of both wires. You may cut wires to your desired length if they are too long.
21. Reinstall distributor in vehicle, making sure rotor is in same position as when removed.
22. Place distributor cap on distributor. All spark plugs wires should be seated securely.
23. See Wiring Instructions.

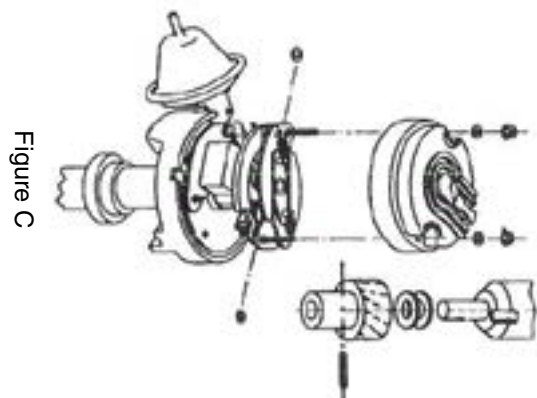
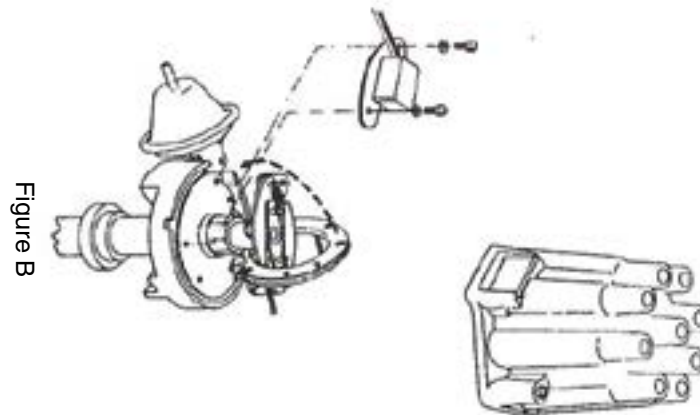
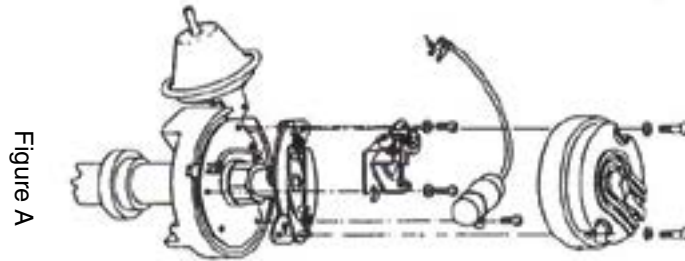

A. Recommended Wiring Installation:

The Ignitor ignition can be used in conjunction with most ignition coils rated at 1.5 ohms of primary resistance on eight cylinder engines and 3.0 ohms on four and six cylinder engines. For optimum performance purchase and install the recommended Flamethrower high performance coil.

Many vehicles came equipped with ballast resistor or resistance wire. To achieve optimum performance from the Ignitor ignition system, we recommend the removal of these components.

- To remove a ballast resistor, (normally white ceramic blocks 3 to 4 inches long), disconnect all wires on both ends of the ballast resistor. Remove the resistor from the vehicle and splice the disconnected wires together at a single point.
 - To remove a resistance wire, trace the coil power wire, which was previously connected to the positive coil terminal, back to the fuse block. Bypass this wire with a 12-gauge copper stranded wire.
1. Attach the black Ignitor wire to the negative coil terminal. (See Figure A)
 2. Attach the red Ignitor wire to the positive coil terminal. (See Figure A)
 3. Check to insure that the polarity is correct, and that all connections are tight.
 4. Re-connect the battery.
 5. Start the engine and allow it to reach normal operating temperature. Check ignition timing, and adjust to the desired setting.

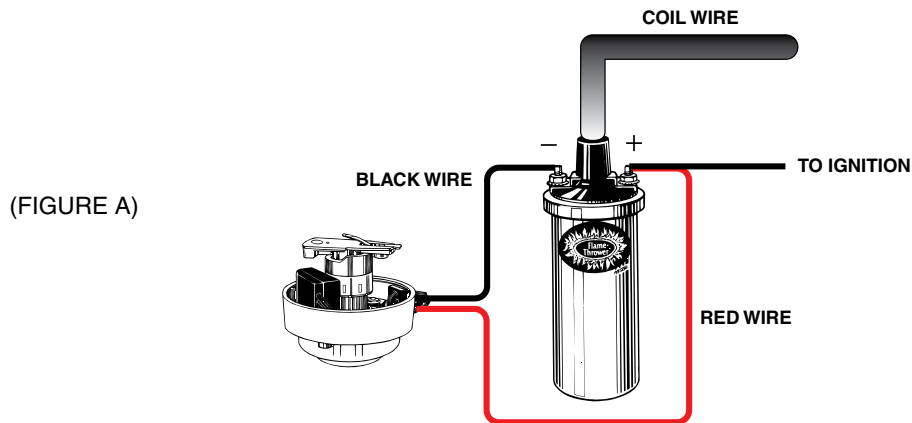

B. Alternative Wiring Installation:

The Ignitor can also be installed in applications retaining the ballast resistor or resistance wire.

1. Attach the Ignitor black wire to the negative coil terminal. (See Figure B)
2. Attach the Ignitor red wire to the ignition side of resistance, or any 12 volt ignition power source. (See Figure B)
3. Check to insure that the polarity is correct, and that all connections are tight.
4. Re-connect the battery.
5. Start the engine and allow it to reach normal operating temperature. Check ignition timing, and adjust to the desired setting.

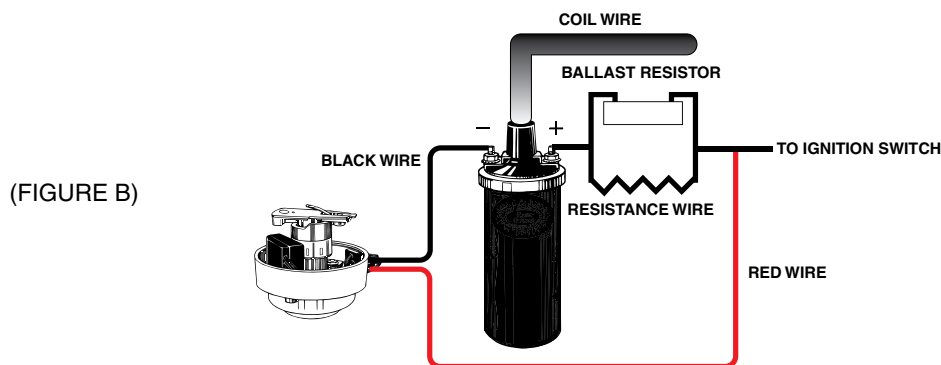

Ignitor COMMON QUESTIONS AND ANSWERS

Q. What is the first thing I should check if the engine would not start?
 A. Make certain all wires are connected securely to the proper terminals.

Q. The engine will not start or runs rough. Are there any tests I can do?
 A. Yes, remove the red ignitor wire from the coil. Connect jumper wire from the positive side of the battery to the red ignitor wire just removed from the coil. If the engine starts, then you have a low voltage problem. Remember this is just a test. Not intended for permanent installation.

Q. How can I fix a low voltage problem?
 A. First, if you have an external ballast resistor or resistance wire, connect the red ignitor wire to the ignition wire prior to the ballast resistor or resistance wire. Second, if you do not have an external resistor you must connect the ignitor red wire to a 12-volt source that is controlled by the ignition switch.

Q. Should I remove the starter bypass wire?
 A. No, the starter bypass wire is needed to provide voltage while starting (cranking).

Q. What type of coil do I need?
 A. The ignitor is compatible only with a "points type" coil. Eight cylinder engines require a minimum of 1.5 Ohms of resistance in the primary circuit. Four & six cylinder engines require a minimum of 3.0 Ohms of resistance (primary).

Q. How do I check my coil for resistance?
 A. First you need an ohmmeter. Remove all the wires from the coil. Attach the ohmmeter to both the positive and negative terminals. The reading should be 1.5

Ohms or greater for eight cylinder engines and 3.0 Ohms or greater for six cylinder engines. (Your local auto parts store can do this for you if you don't have an ohmmeter)

Q. What do I do if my coil does not have enough resistance?
 A. You may purchase and install a ballast resistor from your local auto parts store. You may also choose to purchase a Flamethrower 40,000-volt coil, which provides resistance internally. Note: Many vehicles come with ballast resistor or resistance wire. These applications do not need an additional resistor.

Q. What happens if you leave the ignition switch on when the engine is not running?
 A. This can cause your coil to overheat, which may cause permanent damage to the coil and the ignitor.

Q. May I modify the length of the wires?
 A. Yes, you can cut the wires to any length your application may require. You may also add length of wire if needed (20-gauge wire). Please make sure all wire splice are clean and connections are secure.

Q. Will the shift interrupter on an OMC stern drive boat work with the ignitor?
 A. The ignitor is compatible with all OMC stern drive applications, when equipped with a "diode fix". If you purchased a kit that does not include the "diode fix" diagram, call our tech line.

Q. How can I get additional help?
 A. Call our tech line (909-547-9058) for any further instructions or questions.

POWER & GROUND TESTS

GROUND TESTS

It is imperative that the power and grounds be checked as part of the installation procedure. After installing the Ignitor module and the distributor and with the distributor in the engine, use a digital multi-meter to measure the resistance from the aluminum plate holding the module to battery (-), the net resistance must be less than 0.2 ohms. (Set meter to lowest ohms setting). The net resistance is the meter reading minus the resistance of the meter leads. If the net resistance is greater than 0.2 ohms, the source of the faulty ground must be found and fixed. Usually the source of the bad ground is easily found by holding one probe on an original location and moving the second probe toward the static probe. Where the resistance drops identifies the source.

GROUND TESTS	
Maximum resistance from Ignitor plate to battery negative terminal.	0.2 ohms
EXAMPLE:	
Resistance from Ignitor plate to battery negative (-) terminal.	0.4 ohms
Resistance of meter leads	0.2 ohms
After subtracting meter lead resistance, your net resistance is:	0.2 ohms

VOLTAGE TESTS:

- (Do not disconnect wires from Ignition coil). Place ignition switch in the "off" position.
- Connect a jumper wire from negative (-) terminal of the coil to a good engine ground.
- Connect the voltmeter red lead to the positive (+) terminal of the coil and the black lead to a good engine ground.
- Turn the ignition switch to the "on" position and note voltage reading on the voltmeter. Quickly read the voltage and turn ignition "OFF". Leaving ignition "ON" for an extended period could result in permanent damage to the Ignitor.
- SEE CHART BELOW FOR SPECIFICATIONS.

Note: Low voltage can be caused by poor connections, poor contacts in the ignition switch, ballast resistor, and or a resistance wire in the wiring harness (Factory Installed).

VOLTAGE SPECIFICATIONS	Minimum	Maximum
Ignition Switch "ON"	8.0V	N/A
Cranking	8.0V	N/A
Engine Running	N/A	16.0V

FLAME-THROWER COIL APPLICATIONS						
Use with:	System Voltage	Cylinders	Primary Resistance	Recommended Flamethrower Coils		
				Black	Chrome	Epoxy
Ignitor Only	12V	8	1.5 ohms	40011	40001	40111
Ignitor Only	12V	4 & 6	3.0 ohms	40511	40501	40611
	Agricultural & Industrial					
Ignitor Only	12V	1,2,3,4, & 6	2.8 ohms	28010 or 40511, 40501, 40611		
Ignitor Only	12V	8	1.5 ohms	40011	40001	40111
NOTE: REMOVE OR BYPASS EXTERNAL BALLAST RESISTOR OR RESISTANCE WIRE WHEN INSTALLING THE RECOMMENDED FLAME-THROWER COIL.						

LIMITED WARRANTY

Pertronix, Inc. Warrants to the original Purchaser of its solid-state ignition system (product) that the Ignitor, magnet assembly and wiring (components) shall be free from defects in material and workmanship for a period of (30) months from the date of purchase.

If within the period of the foregoing warranty Pertronix finds, after inspection, that the product or any component thereof is defective, Pertronix will, at its option, repair such products or component or replace them with identical or similar parts PROVIDED that within such period Purchaser:

1. Promptly Notifies Pertronix, in writing, of such defects.
2. Delivers the defective products product or component to Pertronix (ATTN: Warranty) with proof of purchase date; and
3. Has installed and used the product in a normal and Proper manner, consistent with Pertronix printed instructions.

THE FORGOING LIMITED WARRANTY IS EXCLUSIVE AND IN LIEU OF ALL OTHER WARRANTIES, WHETHER EXPRESSED OR IMPLIED, INCLUDING AND IMPLIED WARRANTY OR MERCHANTABILITY OR FITNESS FOR A PURPOSE.

THE FURNISHING OF A REPAIR OR REPLACEMENT COMPONENTS SHALL CONSTITUTE THE SOLE REMEDY OF PURCHASER AND THE SOLE LIABILITY OF PerTronix WHETHER ON WARRANTY, CONTRACT OR FOR NEGLIGENCE, AND IN NO EVENT WILL PerTronix BE LIABLE FOR MONEY DAMAGES WHETHER DIRECT OR CONSEQUENTIAL.

PERTRONIX PERFORMANCE PRODUCTS

440 East Arrow Highway
San Dimas, CA 91773
909-599-5955
www.pertronix.com