



Installation Instructions

Transpak

1980-1992 Ford AOD

Part No. 40227

© 2001, 1994 B&M Racing and Performance Products

IMPORTANT: this **B&M AOD Transpak** will fit all 1980 thru 1992 AOD transmissions, except for electronic versions. If you are installing the kit in a four wheel drive vehicle you will have to purchase a special (four wheel drive) filter screen, Ford p/n E5TZ-7A098-C. We do not recommend using the passenger car filter screen supplied with this kit in four wheel drive vehicle applications. The tool list and parts list are on page 18.

We recommend that you read through the instructions completely before beginning the installation so you can familiarize yourself with the installation procedure and tools required.

Check the tool list at the end of these instructions for the tools required to install your B&M AOD Transpak.

Installation of the **B&M AOD Transpak** can be accomplished by anyone with minimum mechanical experience. It is however, important to closely follow the instructions. Read each step carefully before proceeding, if you do not understand, go back and read the step again.

NOTICE: The **B&M AOD Transpak** is not a cure-all for an ailing transmission. If your transmission is slipping, chatters or is in poor general shape, the installation of this Transpak may

worsen the condition. However on a properly operating transmission in average condition, the **B&M AOD Transpak** will provide the kind of transmission performance you are looking for.

INTRODUCTION

The **B&M AOD Transpak** can be installed in a few hours by carefully following the instructions. Transmission components are precision fit, work slowly and do not force any parts. Burrs and dirt are the number one enemies of an automatic transmission. Cleanliness is very important, so a clean work surface from which oil can easily be removed is necessary.

This kit contains all the parts necessary to obtain two different levels of shift performance, depending on the vehicles intended use. In several of the steps different instructions are given for each level:

1. Heavy Duty; Towing, campers, motor homes and 4-wheel drive vehicles. Heavy duty level produces firm noticeable shifts.
2. Street; Dual purpose performance vehicles, street and strip performance cars. Street level produces the firm, positive shifts.

When installing your **B&M AOD Transpak** there are several other **B&M** products you may wish to con-

sider:

TRANSMISSION OIL COOLER We feel that it is very important that every vehicle used in heavy duty and hi performance applications (racing, towing, RV, etc.) should have an oil cooler. Heat is the major cause of transmission failures, and an oil cooler is an inexpensive safeguard against overheating and transmission failure. **B&M** offers a wide variety of transmission coolers to suit every application. Available at your **B&M** dealer.

TRICK SHIFT PERFORMANCE ATF Trick Shift performance automatic transmission fluid is the industry's only real performance **ATF**. A specially blended oil with foam inhibitors, extreme pressure agents and shift improvers, this fluid assures protection while delivering the fastest possible shifts. You literally "Pour in performance." Available at your **B&M** dealer.

DRAIN PLUG KIT 80250 The AOD transmission is not factory equipped with a drain plug. The **B&M** Drain plug kit is inexpensive and easy to install. It eliminates the mess of pan removal and gasket replacement normally required when changing fluid.

B&M SHIFTERS; **B&M** manufactures a complete line of automatic transmission shifters ideally suited for use with the AOD. These shifters provide you with positive transmission control

Sections of these instructions include copyrighted material from Ford Service Manuals. Reprinted with permission of Ford Motor Company

"S"=(8) Short M6x30mm shoulder bolts

"L"=(17) Long M6x40mm shoulder bolts

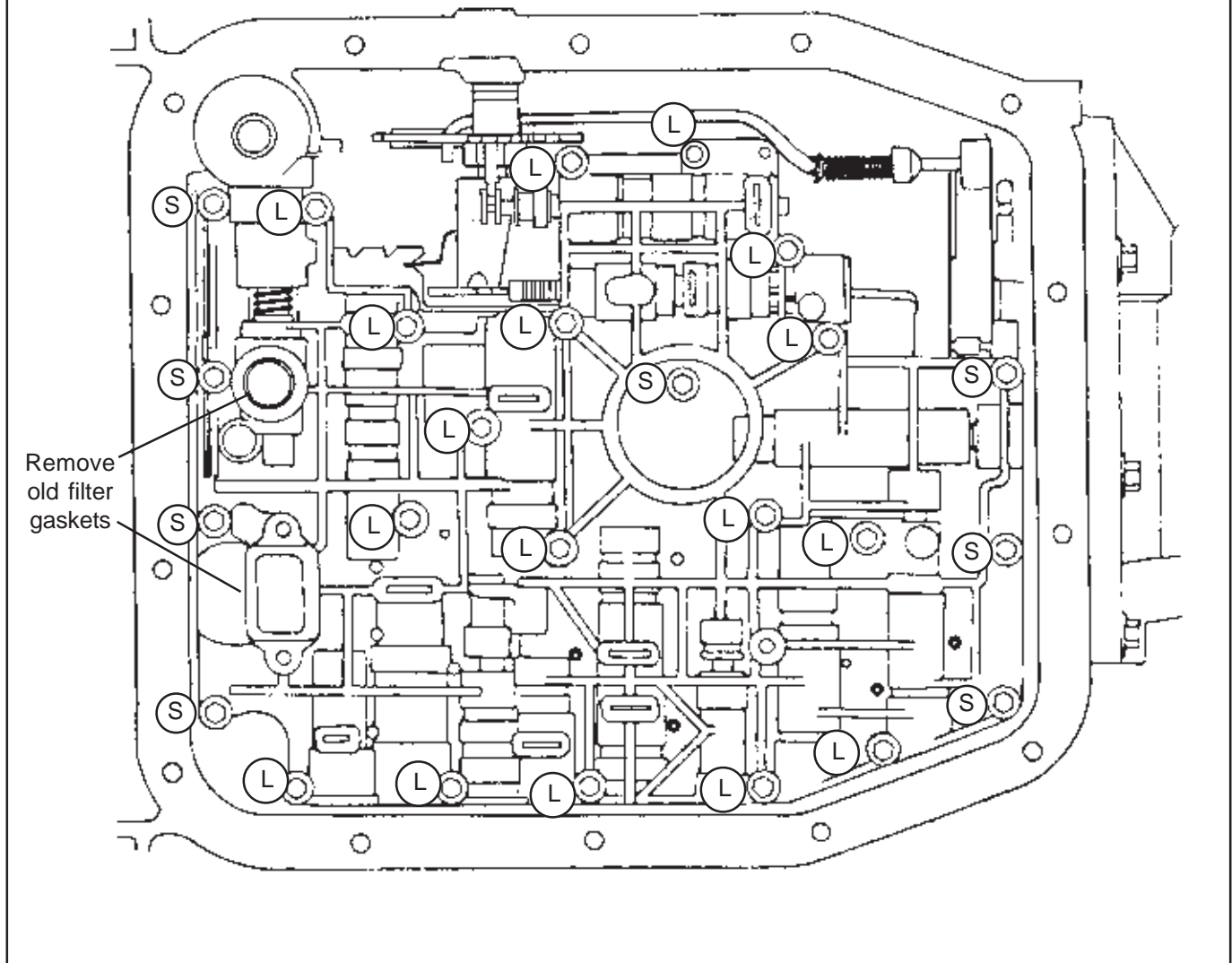

Figure 1

as well as stylish appearance for your vehicles interior. **B&M's** shifters include a model especially designed for the popular 1980-1990 Ford Mustang. Inquire about these shifters at your **B&M** dealer.

TEMPERATURE GAUGE KIT 80212

Most transmission and converter failures can be traced directly to excessive heat. The **B&M** transmission temperature gage can save you a costly repair bill by warning you ahead of time of an overheated transmission. The **B&M** temperature gage is extremely accurate and dependable, it comes with all necessary hardware and is easy to install.

DISASSEMBLY

Automatic transmissions operate

at temperatures between 150 F and 250 F. We recommend that the vehicle be allowed to cool for several hours before attempting disassembly to avoid serious burns from hot oil and parts. The vehicle should be raised so there is at least 2 feet ground clearance for ease of installation and safety.

MAKE SURE THE VEHICLE IS RIGIDLY AND SECURELY SUPPORTED, JACK STANDS, WHEEL RAMP OR A HOIST WORK BEST, DO NOT USE JACKS ALONE.

Have an oil drain pan ready to catch oil and a clean tray on which to put small parts so they won't get lost or dirty.

STEP 1. Since the AOD is not factory equipped with an oil pan drain plug use the following technique to drain

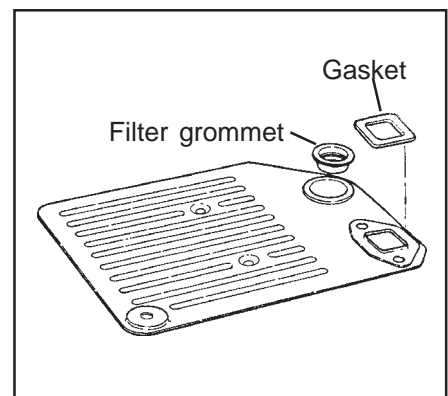

Figure 2

the transmission fluid. Position your drain pan beneath the transmission to catch the oil. Remove all but the two (2) front bolts from the oil pan. Next loosen but do not remove the two front center bolts allowing the rear of

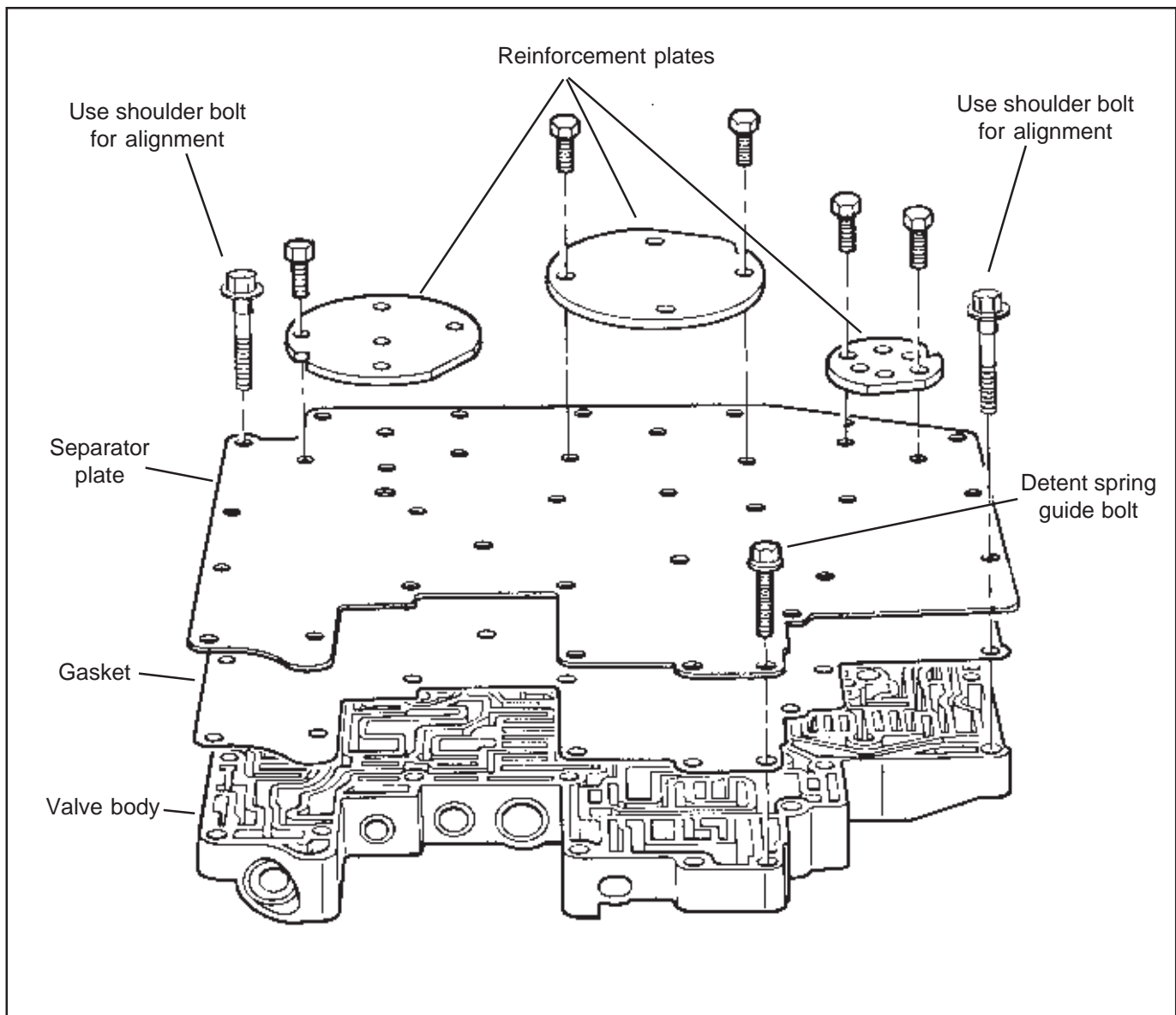

Figure 3

the pan to drop down. If the pan sticks to the gasket, insert a flat screwdriver between the pan and case and pry down gently to break pan loose. Now slowly back the bolts out to permit draining the remaining oil. Remove all old pan gasket material from the pan and case.

STEP 2. Remove three (3) screws holding the oil filter then pull the filter straight down from the valve body. Remove the filter grommet and gasket material from valve body. (See Figs. 1 & 2.)

STEP 3. Remove all of the valve body bolts **except** one near the center (See Fig. 1). Hold valve body up against case and remove the last bolt. When removing valve body watch out for about a pint of oil trapped

above it. Place the valve body on a clean work surface. **WARNING:** Do not place the valve body on the ground or a dirty surface. The valve body consists of precision fit valves and will not tolerate dirt or burrs. Any dirt entering the fluid circuits will jam the shift valves and prevent the transmission from shifting.

VALVE BODY DISASSEMBLY

IMPORTANT: Pay special attention in the following steps where some steps refer to **both** Heavy Duty **and** Street level modifications, while other steps refer **only** to Heavy Duty **or** Street level modifications. If neither performance level is specifically referred to it means **both** Heavy Duty **and** Street levels. It is a good idea to

retain all replaced parts (separator plate, springs, etc.) for reference until after the installation is complete and the vehicle is satisfactorily road tested. **STEP 4.** Remove 12 bolts holding separator plate to valve body (See Fig 3). Remove (3) reinforcement plates and separator plate, (1) large (orange) and (6) small (black) check balls, and (2) relief valves with springs (See Fig. 4). NOTE: Early 1980 valve bodies may have (7) black check balls. Carefully remove any remaining gasket material from reinforcement plates and valve body surfaces. Make sure none of the gasket debris remains in the valve body channels to contaminate the valves. Rinse off valve body with clean solvent to remove any dirt or grit.

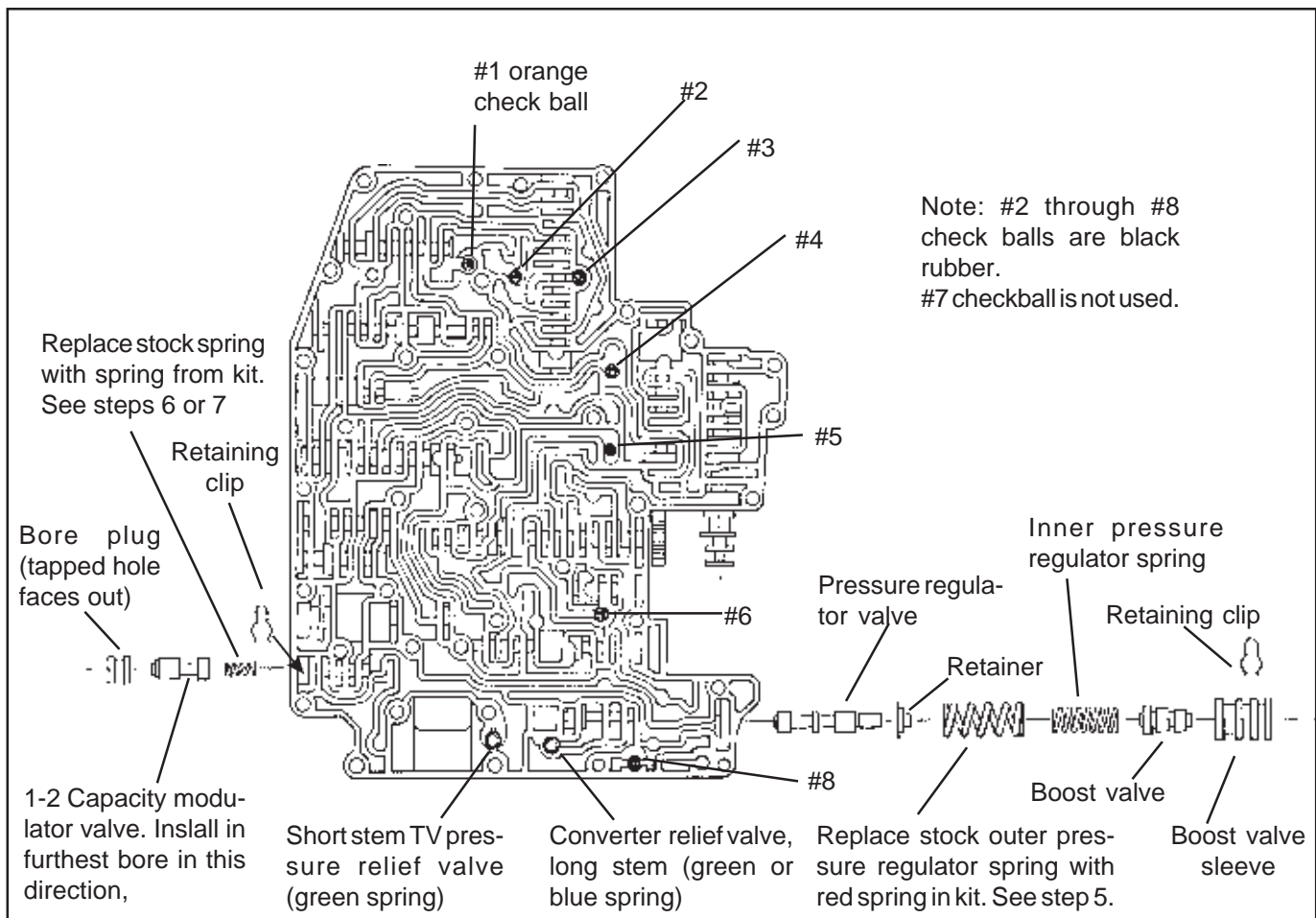

Figure 4

VALVE BODY MODIFICATIONS

IMPORTANT HINT: The spring clips at the end of the valve body bores can fly off during removal. To prevent losing the spring clips place a small rag over the clip when removing it, this will help prevent the clip from flying off and becoming lost. **B&M** does not stock replacement spring clips. If yours are lost or damaged see your local Ford parts supplier or try a transmission shop.

STEP 5. Heavy Duty and Street; Pressure regulator. Remove the retaining clip at the end of the pressure regulator bore (See Fig. 4) Use a screwdriver to hold the pressure regulator assembly in while removing the retaining clip. If the sleeves stick in the bore, lightly punch the sleeve with a small rod and a mallet allowing it to snap back out of the bore. Remove Sleeve with Boost Valve and the outermost pressure regulator spring. Replace the stock outer pressure regulator spring with the **RED** spring supplied in the kit.

Reassemble pressure regulator in reverse order of disassembly.

STEP 6. Heavy Duty Only; 1-2 Capacity Modulator. Remove the spring clip at the end of the 1-2 Capacity Modulator bore (See Fig. 4). Remove the bore plug, 1-2 Capacity Modulator valve and spring from bore. On later model valve bodies use the M4x40 (4mm metric screw supplied in kit) in tapped hole to assist removing bore plug. Early valve bodies do not have a hole in the bore plug so you will have to pry the plug out with a small screw driver. Replace the stock spring with the **YELLOW** spring supplied in kit. Reassemble spring, valve and bore plug (tapped hole facing out) and install spring clip.

STEP 7. Street Only; 1-2 Capacity Modulator. Remove the spring clip at the end of the 1-2 Capacity Modulator bore (See Fig. 4). Remove the bore plug, 1-2 Capacity Modulator valve and spring from bore. On later model valve bodies screw the M4x10

Note: #2 through #8 check balls are black rubber. #7 checkball is not used.

(4mm metric screw supplied in kit) in tapped hole to assist removing bore plug. Early valve bodies do not have a hole in the bore plug so you will have to pry the plug out with a small flat screw driver. Replace the stock spring with the **GREEN** spring supplied in kit. Reassemble spring, valve and bore plug (tapped hole facing out) and install spring clip.

SEPARATOR PLATE MODIFICATIONS

IMPORTANT: The **B&M** AOD separator plate was designed to work with any of the three versions of AOD valve bodies produced between 1980 and 1990. The following steps explain how to set up the **B&M** AOD separator plate for your particular model valve body.

STEP 8. Place the stock separator plate on top of the **B&M** plate with the valve body side of the plates facing up. Install (2) of the short reinforcement plate screws and nuts (supplied in kit) through the alignment holes as

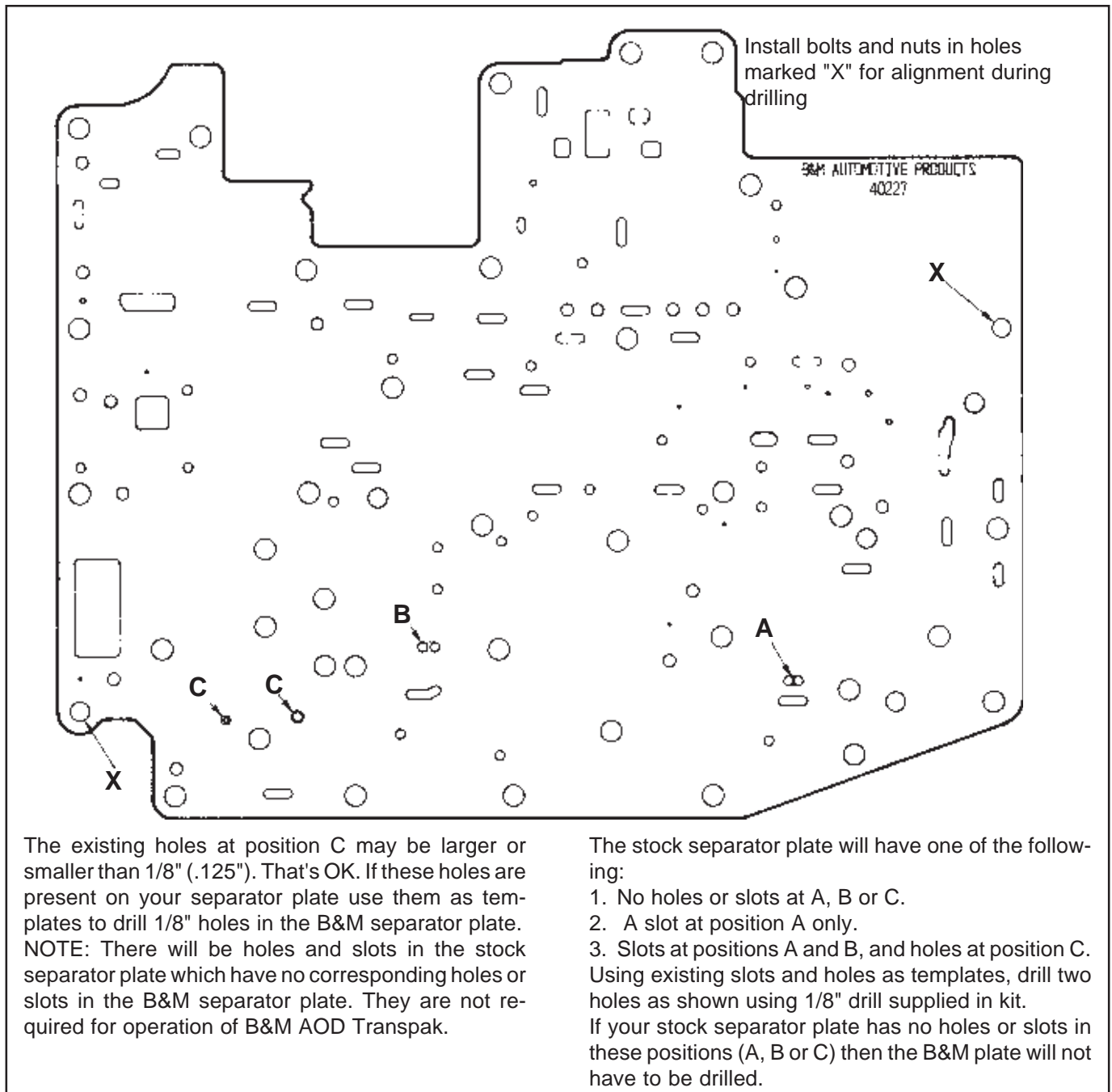

Figure 5

shown. (See Fig 5.) Align both separator plate holes and tighten the (2) bolts until they are just snug.

STEP 9. Using the stock separator plate as a template drill holes in the **B&M** AOD separator plate as indicated in **Figure 5**.

Remove all sharp burrs from plate surface with a fine flat file. Burrs can be removed from around the edge of the holes by lightly pressing a slightly larger drill bit to the hole and spinning it with your fingers.

IMPORTANT: Drill only in the areas

indicated. There are other holes in the stock separator plate that are not used with this kit and should **not** be drilled in the **B&M** plate.

STEP 10. Wash and wipe any loose chips from **B&M** separator plate. **DOUBLE CHECK** the stock plate against the **B&M** plate to make sure all required holes have been drilled.

VALVE BODY ASSEMBLY

STEP 11. Check ball placement (See Fig. 4) Place check balls in the valve body in the positions shown. Use a

dab of grease or petroleum jelly to hold check balls in position. The grease will have no effect on transmission operation and will dissolve after an hour or two of operation. Note the location of the **ORANGE** #1 check ball. The orange and black check balls are not interchangeable.

STEP 12. Reinstall original converter and TV pressure relief springs and valves (See Fig. 4). Pay close attention to the spring color and relief valve stem length. The long stem converter relief valve can have either a green or

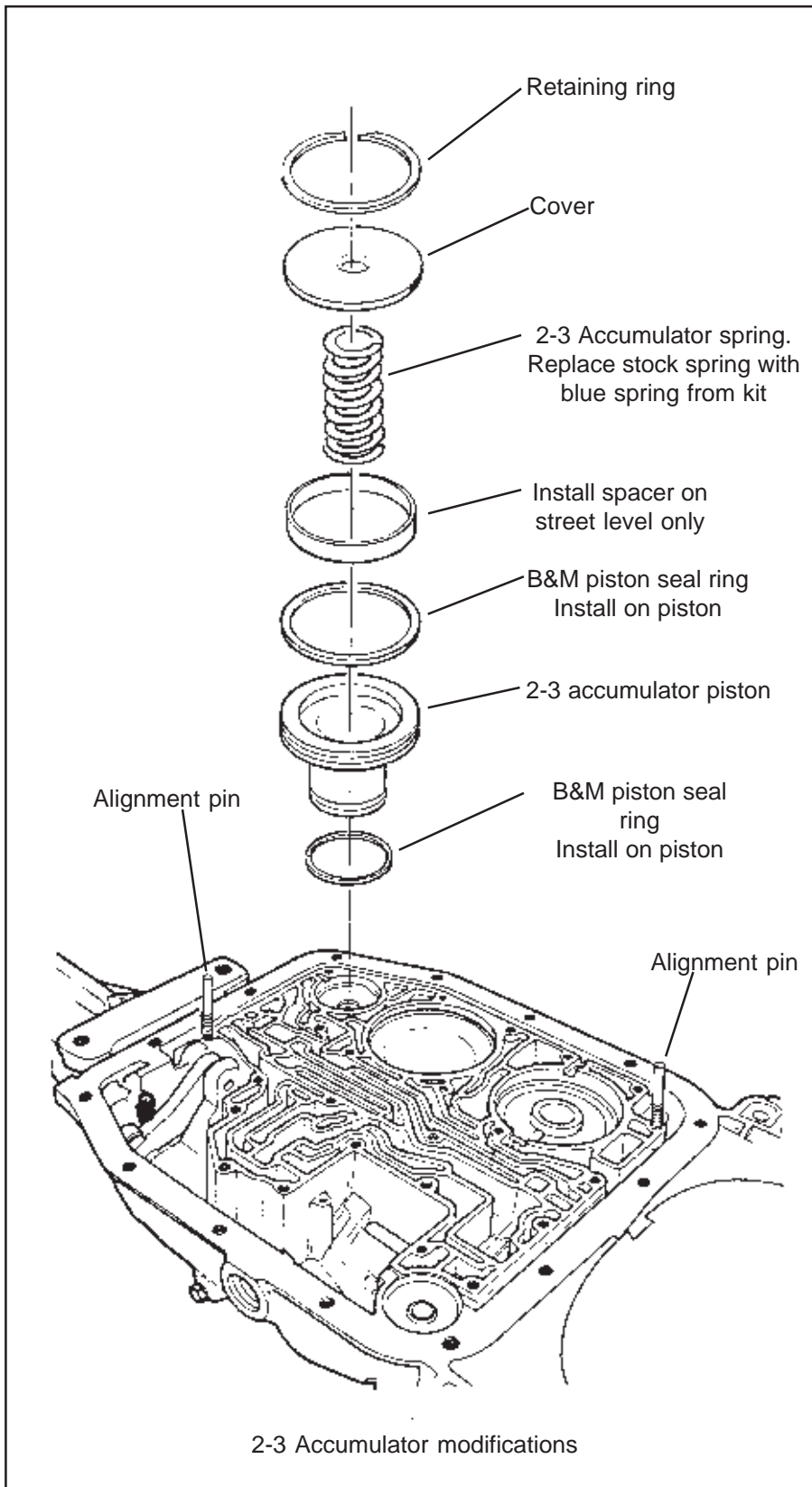

Figure 6

blue spring.

STEP 13. Visually check separator plate gaskets against the **B&M AOD** separator plate to make sure no holes in the separator plate are **covered** by the gasket. **NOTE:** There will be holes

in the gasket that do not have a corresponding holes in the separator plate.

If your gaskets become damaged anytime during the installation of the kit, **replace them**. Purchase stock Ford gaskets for your **specific** year

and model vehicle.

STEP 14. Position separator plate gasket then separator plate on valve body. Align gasket and separator plate holes with those in valve body. Insert (2) long (1.56") valve body **shoulder** bolts through separator plate and valve body as illustrated in **Figure 3**. The **shoulder** bolts are required to maintain gasket and plate alignment during assembly. The shoulder bolts must be installed in the holes indicated for proper alignment. Install (3) reinforcing plates with (11) short bolts tightening the bolts finger tight. Install (1) M6x30mm (1.16") detent spring guide bolt. (**See Fig. 3**)

With all bolts just finger tight make sure all plate and gasket holes line up with valve body holes and the two alignment shoulder bolts can slide in and out freely. Torque the (12) bolts to **80-100 lb.in. (9-11 Nm)**. If you do not have a low range torque wrench, run the bolts down until they stop (wrist tight) then turn bolt an additional one eighth (1/8) turn. Remove the (2) shoulder bolts used for alignment.

2-3 ACCUMULATOR MODIFICATIONS

STEP 15. Remove retaining ring, 2-3 accumulator cover, 2-3 accumulator spring and 2-3 accumulator piston from 2-3 accumulator bore (**See Fig. 6**). Remove (2) seal rings from accumulator piston. Coat the (2) square cut rubber rings supplied in kit with clean AFT then install rings on piston. Install piston back into bore.

STEP 16. Heavy Duty only; Replace stock 2-3 accumulator spring with the **BLUE** spring supplied in kit. Install **BLUE** 2-3 accumulator spring, cover and retaining ring into bore (**See Fig. 6**).

STEP 17. Street only; Replace stock 2-3 accumulator spring with the **BLUE** spring supplied in kit. Install **BLUE** 2-3 accumulator spring, **B&M** 2-3 accumulator spacer, cover and retaining ring (**See Fig. 6**).

FINAL ASSEMBLY

NOTE: If you are installing a B&M shifter in other than a Mustang, this is a good place to install the new shift lever.

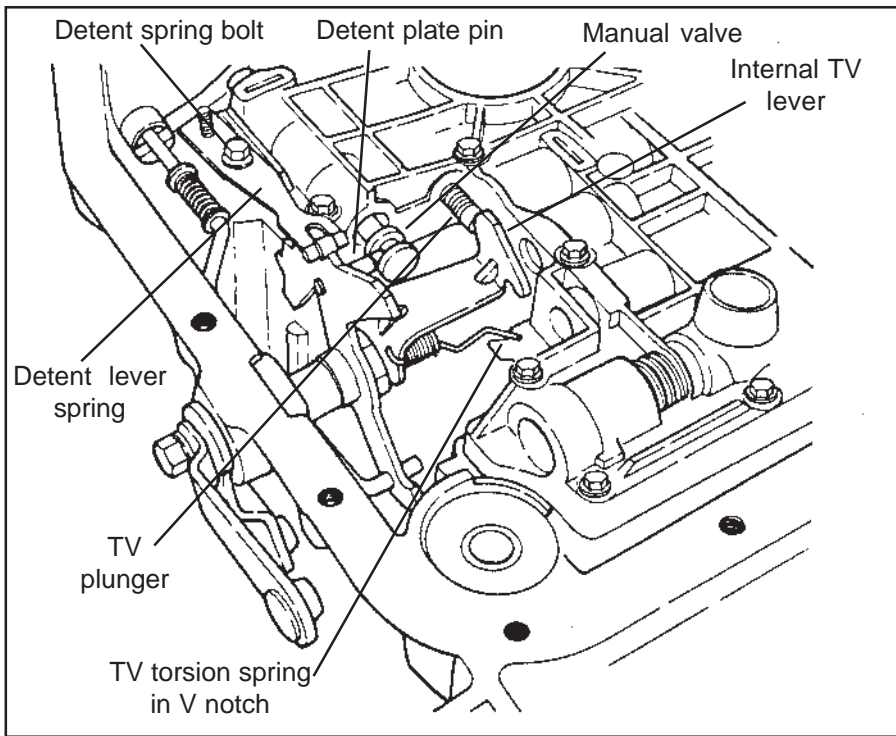

Figure 7

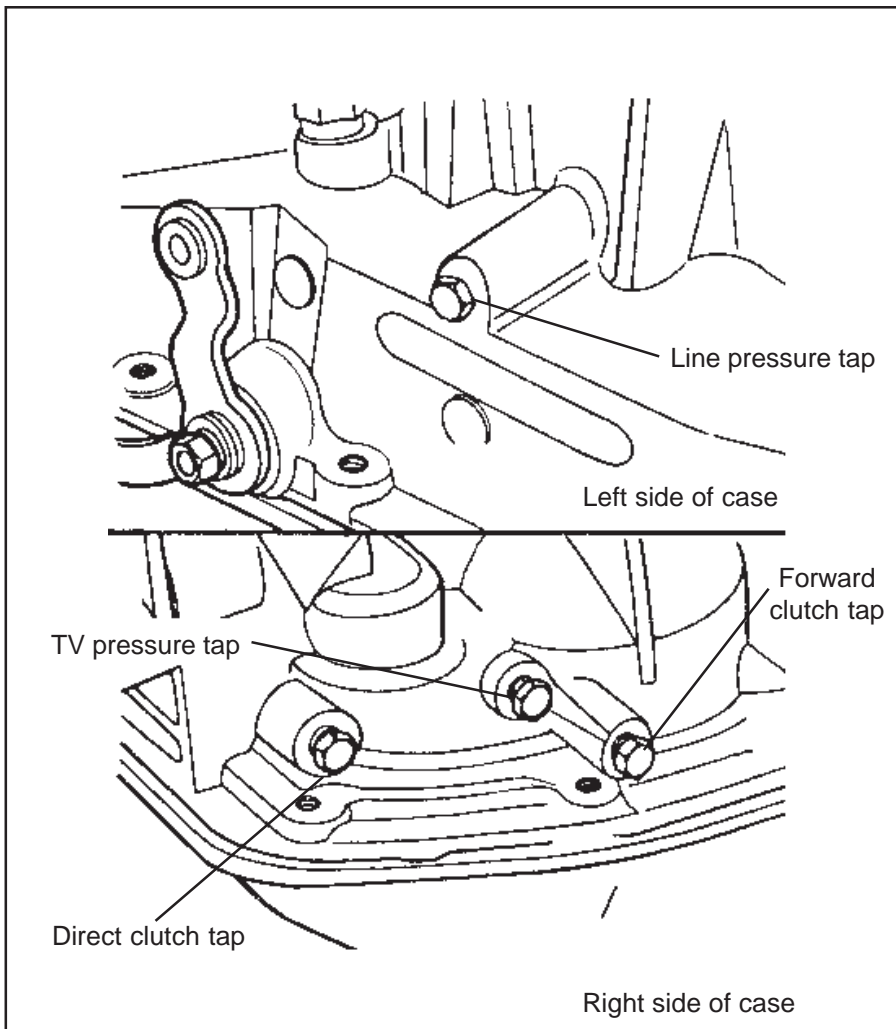

Figure 8

STEP 18. Check your parts before proceeding, you should have (3) stock springs and no check balls or relief valves left over. Make sure the (12) valve body plate bolts are properly torqued.

STEP 19. Remove all old gasket material from the case surface. Install (2) M6x40mm (1.56") alignment pins (supplied in kit) into the holes shown (See Fig. 6). Install case to separator plate gasket over alignment pins. Use a few dabs of grease to hold the gasket against the case.

CAUTION: Valve body installation is one of the most important steps to insure proper operation of the AOD transmission. The valve body must be located flush against the case and carefully torqued exactly as described in the following step. Failure to follow this procedure can result in sticking valves and unpredictable transmission operation. If the valve body is warped or damaged due to improper assembly it is not repairable and should be replaced.

STEP 20. Install valve body up to case being careful to align manual valve with pin in detent plate (See Fig. 7). You also have to manually engage the TV lever between the valve body and TV plunger. **DO NOT** try to force the valve body into place, it will go right into place with a little patience. With the valve body **sitting flush** against the case install (1) bolt to hold the valve body in place. Make sure the detent plate pin and internal TV lever are properly positioned then install (8) short M6x30mm (1.16") and (16) M6x40mm (1.56") shoulder bolts (See Fig. 1). Remove the alignment pins only after all but the last two bolts have been installed. Install **ALL** bolts **FINGER TIGHT**. The short bolts are installed (4) in front (1) in center and (3) in rear of valve body. One of the shoulder bolts holds the detent lever spring. Starting at the center and working outward torque bolts to **80-100 lb.in. (9-11 Nm)**. If you do not have a low range torque wrench, run the bolts down until they stop (wrist tight) then turn bolt an additional one eighth (1/8) turn.

STEP 21. Position the TV torsion spring against the separator plate 'V'

notch(See Fig. 7). The TV torsion spring pushes the TV lever against the TV plunger. **Failure to position this spring properly will result in erratic shifting.**

STEP 22. Make sure rubber grommet is installed in the new filter supplied with kit. Install the cork filter gasket on filter using a dab of grease to hold it in place (See Fig. 2.). Coat the filter grommet with clean ATF and install filter on valve body. Push the filter straight on to avoid damaging the rubber grommet. Install (3) M6x16 (0.63") bolts and torque to **80-100**

lb.in. (9-11 Nm).

STEP 23. Remove any old pan gasket material from pan and case pan rail. Clean inside of pan with solvent. If you recall what a mess draining the pan was, you may want to install a **B&M Drain plug kit (80250)** at this time. Install the new pan gasket on the pan and align the holes. Use grease or petroleum jelly to help hold the gasket in place during installation of pan. Place pan up to case, align holes and install all bolts finger tight. After all bolts have been installed, torque bolts to **72-124 lb. in. (8-14 Nm)**. If

the bolts are over tightened the gasket will deform excessively and lead to oil leaks.

STEP 24. Fill transmission with fresh automatic transmission fluid to the full mark on the dip stick. We recommend **B&M Trick Shift** transmission fluid for all applications, particularly for Street Level applications. You will need approximately 6 to 8 quarts.

TV Linkage Adjustment

STEP 25. TV Linkage Adjustment:

Normally the TV linkage does not need to be adjusted after installing the valve body. Proper installation of this kit will not change the setting of the linkage (follow instruction procedures). The linkage normally requires adjustment only when the transmission is installed in the vehicle or when there is a new carburetor or throttle body installed. We recommend, however, performing a Line and TV pressure check to check whether or not the TV Linkage is properly adjusted (See Oil Pressure Chart). If the pressure check indicates TV linkage adjustment is required see the TV linkage adjustment section on the following pages. The pressure test will also give you a good indication of the transmissions condition.

Line Pressure Test Results

Low at idle in all ranges: Check for low fluid level, clogged or damaged filter, loose valve body bolts, stuck pressure regulator valve, missing pressure regulator spring or oil temperature too hot from excessive W.O.T. test.

Low at W.O.T. but O.K. at idle: Check for low oil level, clogged filter, damaged or out of adjustment TV linkage, Sticking TV or TV limit valve in valve body.

STEP 26. Inspect the transmission for leaks with engine running. Lower vehicle and check fluid level again adjusting level as required. Test drive vehicle and recheck for leaks while transmission is hot.

Ford Service Manuals available from Helms Inc., Detroit, MI., (313) 865-5000.

Ford service tools available from OTC Tool and Equip., Owatonna, MN., (507) 455-7050.

Line Pressure check

*On the AOD transmission two pressure readings must be taken: One at idle (closed throttle, Zero TV Press.) and another at wide open throttle (W.O.T., Full TV Press.).

*Engine and transmission should be at normal operating temperature for test.

*During test at W.O.T. (stall) the wheels must be locked to prevent any vehicle motion.

*DO NOT operate at W.O.T. Stall for more than 10 seconds at a time, followed by at least 2 minutes in Neutral at 1000 RPM to cool the oil.

*Connect a 0-300 PSI (0-2000 kPa) pressure gage to the line pressure port located just above the control levers on the right side of the transmission (See Fig. 8). The gage hose must be long enough to read gage while operating engine.

*Connect a 0-100 PSI (0-690 kPa) gage (300 PSI gage will work if it's all you have) to the TV Pressure tap on the right hand side of the transmission (See Fig. 8). The gage hose must be long enough to read gage while operating engine.

*Idle pressure **must** be read with throttle off the fast idle cam.

*Pressures listed apply to stationary vehicle only. In 3rd and 4th gears line pressure is lower (cut back) than shown for "all other ranges".

Oil Pressure Specifications

Selector Position	Line Pressure		TV Limit Pressure	
	PSI	(kPa)	PSI	(kPa)
At idle				
In Reverse	109-129	(751-890)	0	0
All Other Ranges	74-94	(510-648)	0	0
At W.O.T. (Stall)				
In Reverse				
3.8L & 4.9L	264-304	(1820-2096)	74-86	(510-593)
All other engines	275-315	1896-2172)	79-91	(545-627)
All Other Ranges				
3.8L & 4.9L	200-220	(1379-1517)	74-86	(510-593)
All other engines	209-229	(1441-1579)	79-91	(545-627)

TROUBLESHOOTING GUIDE FOR THE FORD AOD TRANSMISSION

The troubleshooting guide is intended to help you identify possible causes of malfunctions that could be related to incorrect assembly or adjustment of the transmission hydraulic system (valve body and accumulator) and/or mechanical controls. We recommend that you obtain an AOD service manual for problems related to the torque converter or transmission hard parts.

Slow initial engagement	Low line pressure Fluid level low
Harsh initial engagement	Engine idle too high Loose U-joints or engine mounts High line pressure Sticking valves in valve body 2-3 accumulator valve damaged
No drive in any selector position	Valve body leaking internally Valve body bolts loose Sticking valves in valve body Manual valve pin not engaged Fluid level low
No drive forward, but has reverse	Worn or stuck governor Valve body bolts loose Sticking valves in valve body Damaged 2-3 accumulator seal
Slips or chatters in 1st gear (Selector in "OD")	TV linkage out of adjustment Low line pressure Valve body bolts loose
Slips or chatters in 2nd gear (Selector in "OD", OK in 1st) Slips or chatters in Reverse	Defective intermediate clutch Sticking valves in valve body Low line pressure Valve body bolts loose
Starts in 2nd or 3rd	Sticking governor Sticking valves in valve body Cross channel leaks between case or separator plate and valve body
Incorrect shift points	TV linkage out of adjustment Worn governor Sticking valves in valve body
NO 1-2 upshift	TV linkage out of adjustment Governor valve sticking Sticking valve in valve body
Mushy 1-2 shift	Out of tune engine Defective intermediate clutch TV linkage out of adjustment Low line pressure
No 2-3 upshift	Defective direct clutch Converter damper hub broken Sticking valve in valve body
Mushy 2-3 upshift	Defective 2-3 accumulator piston or seals Low line pressure
Mushy or rough 3-4 upshift	Out of tune engine Defective OD band or reverse drum TV linkage out of adjustment
No forced down shifts	Defective clutch or band TV linkage damaged or out of adjustment Sticking valve in valve body
Transmission overheats	Too high idle speed or overheated engine Restriction in cooler or lines Converter overrun clutch seized Sticking valves in valve body
Transmission noise	Relief valve resonance (buzzing) Oil pump cavitation

TV LINKAGE ADJUSTMENT

Three different types of Throttle Valve (TV) linkages have been used on the Ford AOD transmission since its introduction. The earliest linkage consisted of a bent rigid rod connecting the carburetor and transmission while most late model AOD's use one of two different flexible cable type linkages. **NOTE:** Special tools and a pressure gage will be required depending on the particular TV linkage type you are working on. Adjustment procedure for each of the TV linkage types are presented in the following sections.

1. Carburetor adjustment

Perform the following steps prior to adjusting TV linkage.

- 1.1 Check/adjust the engine curb idle speed to specification. Refer to the Engine/Emissions Diagnosis manual for procedures to adjust throttle solenoid applications. Make sure the curb idle speed is set to specification with and without the throttle solenoid positioner (anti-dieseling solenoid) energized, if so equipped.
- 1.2 Shut engine off. Remove air cleaner.
- 1.3 De-cam the fast idle cam on the carburetor so that the throttle lever is against the idle stop or throttle solenoid positioner stop.

Rod type TV control system.

The TV control linkage system consists of a linkage lever on the carburetor, the TV control rod assembly and an external TV control lever on the transmission. (See Fig. 9.) The TV control rod transmits motion between the carburetor linkage lever and the TV control lever on the transmission. The carburetor linkage lever has an adjustment screw for limited TV linkage Adjustment. The external TV control lever actuates the internal TV control mechanism which regulates TV control pressure.

The TV control rod is set to its proper length during initial assembly using the sliding trunnion block at the transmission end of the TV control rod assembly. Under normal circumstances it should not be necessary to alter this Adjustment. Any required adjustment can normally be made using the adjustment screw on the carburetor linkage lever.

When the linkage is correctly adjusted, the TV control lever on the transmission will be at its internal stop position when the carburetor lever is at its minimum idle stop. There will be light contact force between the throttle lever and the end of the linkage lever adjustment screw. Due to the flexibility in the TV linkage the adjustment screw would have to be backed out several turns before a gap between the screw and throttle lever could be detected.

Before any engine TV linkage adjustment can be done, the throttle lever at the carburetor (or throttle body) must be positioned at its minimum idle stop.

2. Linkage Adjustment at Carburetor

Adjust the TV control linkage at the carburetor using the following procedure (See Fig. 9.):

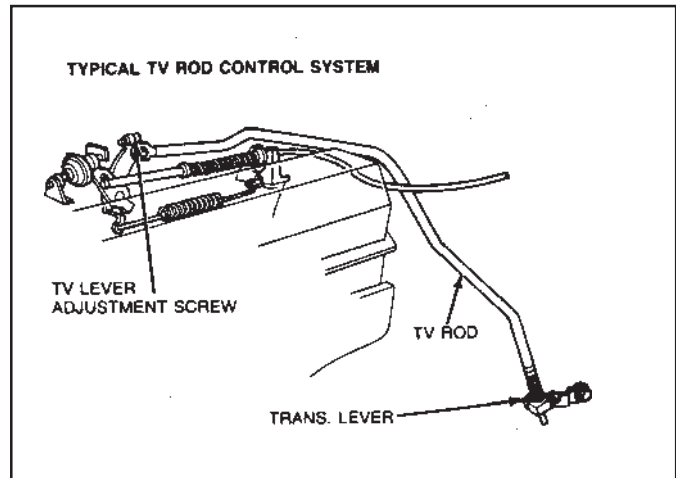

Figure 9

- 2.1 Set carburetor at minimum idle stop as described in steps 1 thru 3. Place shift lever in NEUTRAL and set parking brake. **CAUTION:** The transmission selector lever must be in NEUTRAL in when adjusting the TV linkage.
- 2.2 Back (turn CCW) the linkage lever adjusting screw all the way out (until screw end is flush with lever face).
- 2.3 Turn the adjusting screw in (CW) until a thin shim of .127mm (0.005 inch) maximum, or piece of writing paper fits snug between end of screw and throttle lever. **NOTE:** To eliminate effect of friction, push linkage lever forward (tending to close gap) and release before checking clearance between end of screw and throttle lever. Do not apply any load on levers with tools or hands while checking gap.
- 2.4 Turn the adjusting screw in (CW) an additional three turns. (Three turns are preferred. One turn minimum is permissible if screw travel is limited).
- 2.5 If it is not possible to turn in adjusting screw at least one additional turn (from initial gap) or if there was insufficient screw adjusting capacity to obtain an initial gap in Step 5, refer to Linkage Adjustment at Transmission.

Idle Speed Adjustment

Whenever it is required to adjust idle speed by more than 50 rpm, the adjustment screw on the linkage lever at the carburetor should also be readjusted as follows:

Idle Speed Change

- 50 rpm or more decrease
- Less than 50 rpm
- 50 rpm or more increase

Linkage Adjustment at Carburetor

- Check TV lever adjustment at carburetor
- No change required
- Check TV lever adjustment at carburetor

After making any idle speed adjustments, always verify that the linkage lever and throttle lever are in contact with the throttle lever at its idle stop (or throttle solenoid positioner) and the shift lever is in NEUTRAL.

3. Rod Linkage Adjustment at Transmission

The linkage lever adjustment screw has limited adjustment capability. (See Fig. 9.) If it is not possible to adjust the TV linkage using this screw, the length of the TV control rod assembly must be readjusted using the following procedure. This procedure must also be followed whenever a new TV control rod assembly is installed.

This procedure requires raising the vehicle to give access to the linkage components at the transmission TV control lever.

3.1 Set carburetor at its minimum idle stop as described in steps 1-3. Place shift lever in NEUTRAL and set parking brake. Turn engine off.

3.2 Set the carburetor linkage lever adjustment screw at approximately half-travel.

3.3 If a new TV control rod assembly is being installed, connect the rod to the linkage lever at the carburetor.

CAUTION: The following steps involve working in close proximity to the exhaust system. Allow the exhaust system to cool before proceeding.

3.4 Raise vehicle so there is at least 2 feet ground clearance for ease of access. **MAKE SURE THE VEHICLE IS RIGIDLY SUPPORTED ON JACK STANDS OR WHEEL RAMPS IF A HOIST IS NOT AVAILABLE. DO NOT USE JACKS ALONE TO SUPPORT VEHICLE.**

3.5 Loosen the bolt on the sliding trunnion block on the TV control rod assembly. Remove corrosion and road grime from the control rod and free-up the trunnion block so that it slides freely on the control rod.

3.6 Push up on the lower end of the control rod to ensure that the linkage lever at carburetor is touching firmly against the throttle lever. Release force on rod. Rod must stay up.

3.7 Push the TV control lever on the transmission up against its internal stop with a firm force, approximately 22 N (5 lbs). Tighten the bolt on the trunnion block. Do not relax force on lever until bolt is tightened.

3.8 Lower the vehicle and verify that the throttle lever is still against the minimum idle stop or throttle solenoid positioner stop. If not, repeat Steps 14 and 15.

4 Rod type Linkage Adjustment Using TV Control Pressure

Note: This procedure requires the use of TV Pressure Gauge with Hose (0-60 psi) T86L-70002-A or equivalent. The results of the adjustment procedure depends on the accuracy of the pressure gauge.

The following procedure may be used to check and/or adjust the throttle valve (TV) control linkage using the TV control pressure. (See Fig. 10.)

4.1 Check/adjust the engine curb idle speed to specification required. Refer to the Engine/Emissions Diagnosis manual for appropriate procedure. Ensure the curb idle speed is set to specification with and without the throttle solenoid positioner (anti-diesel solenoid) energized, if so equipped.

4.2 Attach Pressure Gauge (0-60 psi) with Hose T86L-70002-A and Adapter Fitting D80L-77001-A or equivalent, to the TV port on the transmission. The pressure

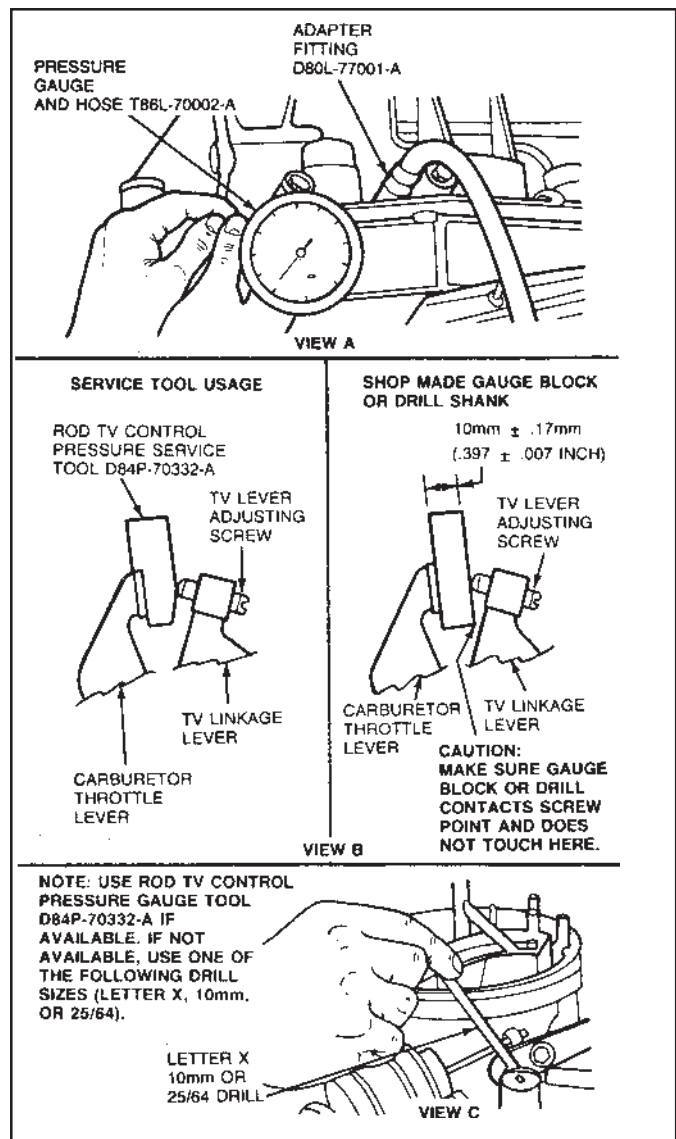

Figure 10

gauge should have 2.4m (8 feet) of flexible hose to make the gauge accessible while operating the engine.

4.3 Obtain TV Control Pressure Gauge Block D84P-70332-A or fabricate a block $.394" \pm 0.007"$ thick. The following drill bit shanks may also be used in order of preference: Letter X (.397 inch), 10mm (.3937 inch) or 25/64 (.3906 inch).

4.4 Operate the engine until normal operating temperature is reached and the throttle lever is off fast idle. The transmission fluid temperature should be approximately $38^\circ - 72^\circ \text{ C}$ ($100^\circ - 150^\circ \text{ F}$). Do not make pressure check if transmission fluid is cold or too hot to touch.

4.5 Set parking brake, place shift selector in NEUTRAL, remove air cleaner and shut off air conditioner. If equipped with a vacuum operated throttle modulator, disconnect and plug the vacuum line to this unit. If equipped with a throttle solenoid positioner or an idle speed control, do not disconnect either of these components.

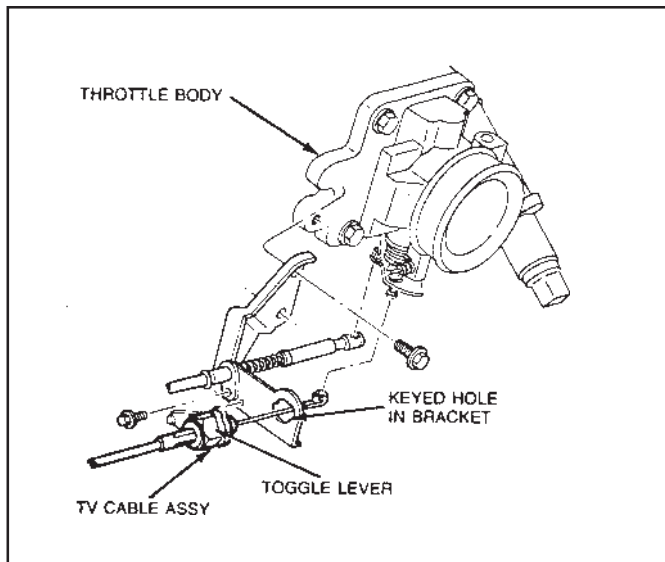

Figure 11

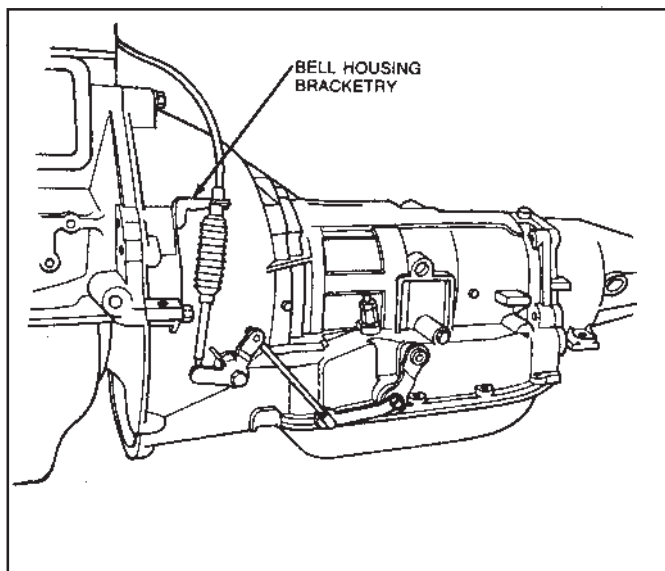

Figure 12

NOTE: The following pressure check must be made with the engine idling at normal curb idle in NEUTRAL, parking brake set and with no accessory load on engine. Do not make pressure check in PARK.

4.6 With engine idling in NEUTRAL, insert gauge block or drill shank between the carburetor throttle lever and adjust screw on the transmission linkage lever. The TV pressure should be between 207 and 276 kPa (30 and 40 psi). For best transmission function, use the adjusting screw to set the pressure as close as possible to 227 kPa (33 psi). Since the TV pressure goes up approximately 14 kPa (2 psi) when the shift lever is moved from NEUTRAL to a forward gear, this will result in a TV pressure setting near the desirable 241 kPa (35 psi in forward gear). **Do not attempt to set TV pressure with the transmission in gear.** Turning the screw in will raise the pressure 10.3 kPa (1.5 psi) per turn. Backing-out the screw will lower the pressure. If equipped with idle speed control, some "hunting" may

occur and an average pressure reading will have to be determined. If the adjusting screw does not have enough adjustment range to bring TV pressure within specification, adjust rod at the transmission.

4.7 Remove gauge block, allowing TV lever to return to idle. With engine still idling in NEUTRAL, TV pressure must be less than 34 kPa (5 psi). If not, back-out adjusting screw until TV pressure is less than 34 kPa (5 psi). Install gauge block and check that TV pressure is not below 207 kPa (30 psi).

Manual-Locking type cable Throttle Valve (TV) Control Cable System.

3.8 L (Thunderbird/Cougar) Engines

The throttle valve (TV) control cable system consists of a cable attaching stud on the throttle body throttle lever, the TV control cable assembly, the external TV control lever on the transmission, and the cable mounting brackets at the throttle body and transmission. (See Figs. 11 & 12.)

On 3.8 L EFI Thunderbird/Cougar vehicles, there is also a bellcrank assembly mounted on the transmission bell housing in the area of the TV lever and bracketry holding the cable in the upper bell housing area (same as 5.0 L Thunderbird/Cougar vehicles with column shift).

As the throttle is moved from idle to wide open throttle (WOT), the TV control cable pulls the transmission TV control lever from idle to WOT. Return of the cable and transmission lever toward idle is accomplished by the return spring on the transmission end of the cable assembly. This spring and the end of the cable assembly is protected by a flexible rubber boot. The transmission external TV control lever actuates the internal TV control mechanism which regulates the TV control pressure. The travel of this lever is controlled by stops internal to the transmission.

The TV control cable is set and locked to its proper length during initial assembly by pushing down on the locking lever at the throttle body end of the cable assembly. When the lever is unlocked, the cable is released for adjustment. The take-up spring at this end of the cable automatically tensions the cable when released. With the slack taken up and the locking lever pushed, the take-up spring plays no part in the operation of the system.

Under normal circumstances, it should not be necessary to alter or readjust the initial setting of the TV control cable. Situations requiring readjustment of the TV control cable include maintenance involving the removal and/or replacement of the throttle body, transmission, TV cable assembly or installing a new main control assembly. Readjustment of the TV control cable would also be necessary to correct complaints of poor transmission shift quality that would have been caused by a misadjustment of the TV control cable.

When the TV control cable is properly set, the transmission TV control lever will be at its internal idle stop (lever to rear as far as it will travel) when the throttle lever is at its idle stop.

Idle Speed Affect on TV Control Cable

The EFI (Electronic Fuel Injection) engine uses an Air Bypass (ISC) that does not affect throttle position. Therefore, idle automatic setting does not affect TV cable adjustment.

5. Manual locking cable adjustment using TV Control Pressure.

- 5.1 Attach TV pressure gauge (60 PSI) with hose T86L-70002-A or equivalent to TV pressure tap (See Fig. 8).
- 5.2 Obtain Cable TV Gauge tool T86L-70332-A or equivalent.
- 5.3 Insert tapered end of the tool between the crimped slug on the end of cable and plastic cable fitting that attaches to the throttle lever. (See Fig. 13.) Push in Cable TV Gauge Tool T86L-70332-A, or equivalent forcing the crimped slug away from the plastic fitting. Ensure gauge block is pushed in as far as it will go.

WARNING: THIS PROCEDURE REQUIRES WORKING IN CLOSE PROXIMITY TO THE EGR SPACER ASSEMBLY WHICH MAY BE HOT.

- 5.4 Operate engine until normal operating temperature is reached. The transmission fluid temperature should be approximately 38-72°C (100-150°F). Do not make pressure check if transmission fluid is cold or too hot to touch.
- 5.5 Set parking brake and place shift selector in NEUTRAL. With gauge tool in place and engine idling in NEUTRAL, the TV pressure should be between 207 and 276 kPa (30 and 40 psi). For best transmission operation, set TV pressure as close as possible to 227 kPa (33 psi), using the following procedure.
- 5.6 Since the TV pressure goes up approximately 14 kPa (2 psi) when the shift lever is moved from NEUTRAL to a forward gear, this will result in a TV pressure setting near the desirable 241 kPa (35 psi) in forward gear. Do not attempt to set TV pressure with the transmission in gear. **NOTE:** Do not check or set TV pressure in PARK.
- 5.7 Using a screwdriver or pointed tool, pry up white toggle lever on cable adjuster located immediately behind the throttle body cable mounting bracket. (See Fig. 14.) The adjuster preload spring should cause the adjusting slider to move away from the throttle body and TV pressure should increase.
- 5.8 Push on the slider from behind bracket until TV pressure is 227 kPa (33 psi). While still holding slider, push down on toggle lever as far as it will go, locking slider in position. (See Fig. 15.) **NOTE:** Toggle lever must be completely down (lying flat in cable adjuster assembly) to lock properly.
- 5.9 Remove gauge tool, allowing cable to return to its normal idle position. With engine still idling in NEUTRAL, TV pressure must be at or near 0 kPa (0 psi) (less than 34 kPa (5 psi)). If not, reinstall gauge and repeat Steps 7 and 8 but set TV pressure to a pressure less than 227 kPa (33 psi) but no less than 207 kPa (30 psi). Remove gauge tool and recheck TV pressure to determine if it is at or near 0 kPa (0 psi).

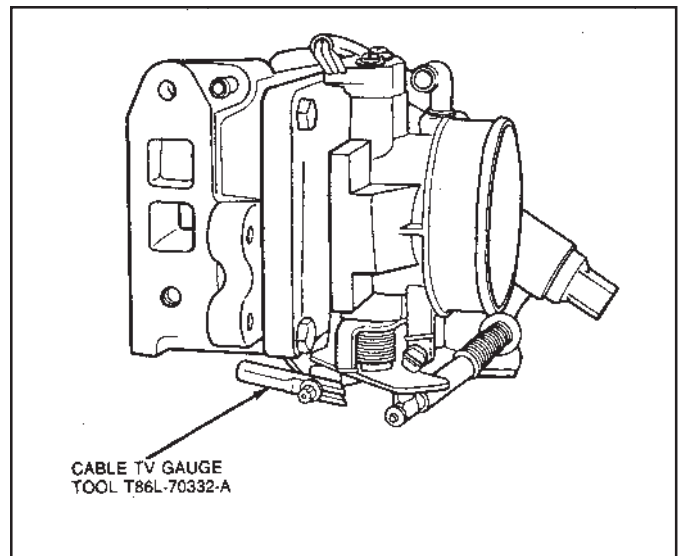

Figure 13

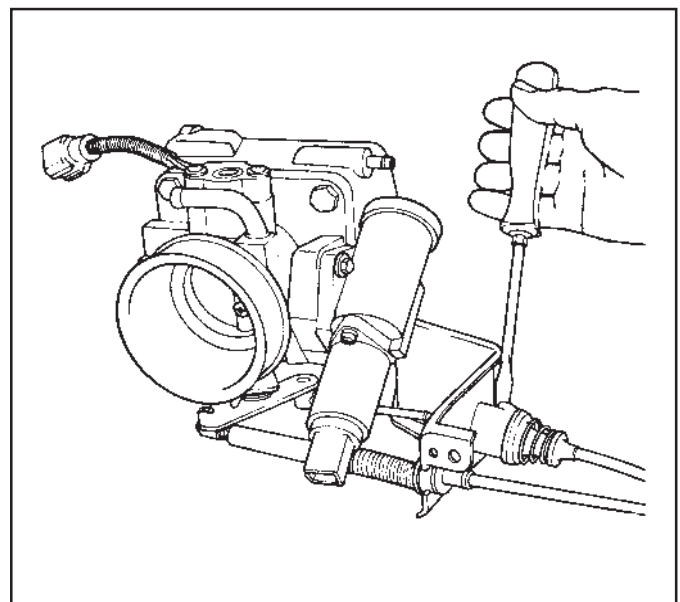

Figure 14

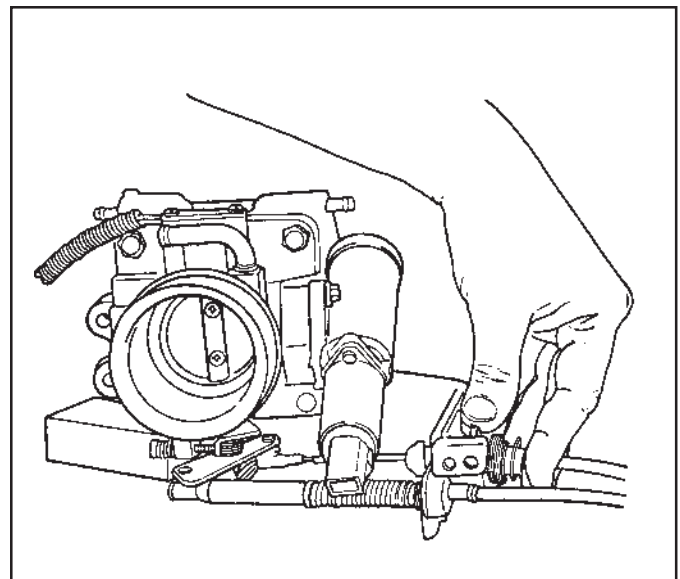

Figure 15

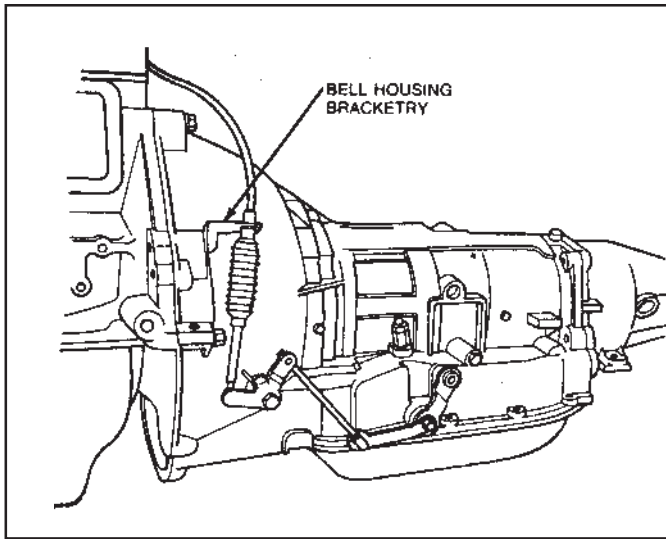

Figure 16

Self-locking type cable Throttle Valve (TV) Control Cable System.

5.0 L HO and SEFI Engines

The throttle valve (TV) control cable system consists of a cable attaching grommet on the throttle body throttle lever, the TV control cable assembly, the external TV control lever on the transmission, and cable mounting brackets at the throttle body and transmission. (See Figs. 16, 17, 18 & 19.)

On Thunderbird/Cougar vehicles with column shift and 3.8 L engines, there is also a bellcrank assembly mounted on the transmission bell housing in the area of the TV lever and bracketry holding the cable in the upper bell housing area.

As the throttle is moved from idle to wide-open throttle (WOT), the TV control cable pulls the transmission TV control lever from idle to WOT. Return of the cable and transmission lever toward idle is accomplished by the return spring on the transmission end of the cable assembly. This spring and the end of the cable assembly is protected by a flexible rubber boot. The transmission external TV control lever actuates the internal TV control mechanism which regulates the TV control pressure. The travel of this lever is controlled by stops internal to the transmission.

The TV control cable is set and locked to its proper length during initial assembly when the grooved pin on the upper end of the cable assembly is inserted in the grommet on the throttle body lever. To release the cable locking mechanism, it is necessary to pry the grooved pin out of the grommet and push out the white locking pin. The take-up spring at the end of the cable assembly tensions the cable and takes up the slack in the system. When the grooved pin is reinserted in the grommet, the white locking tab is pushed in, automatically locking the cable to its correct length. When the cable is locked, the take-up spring plays no part in the operation of the system.

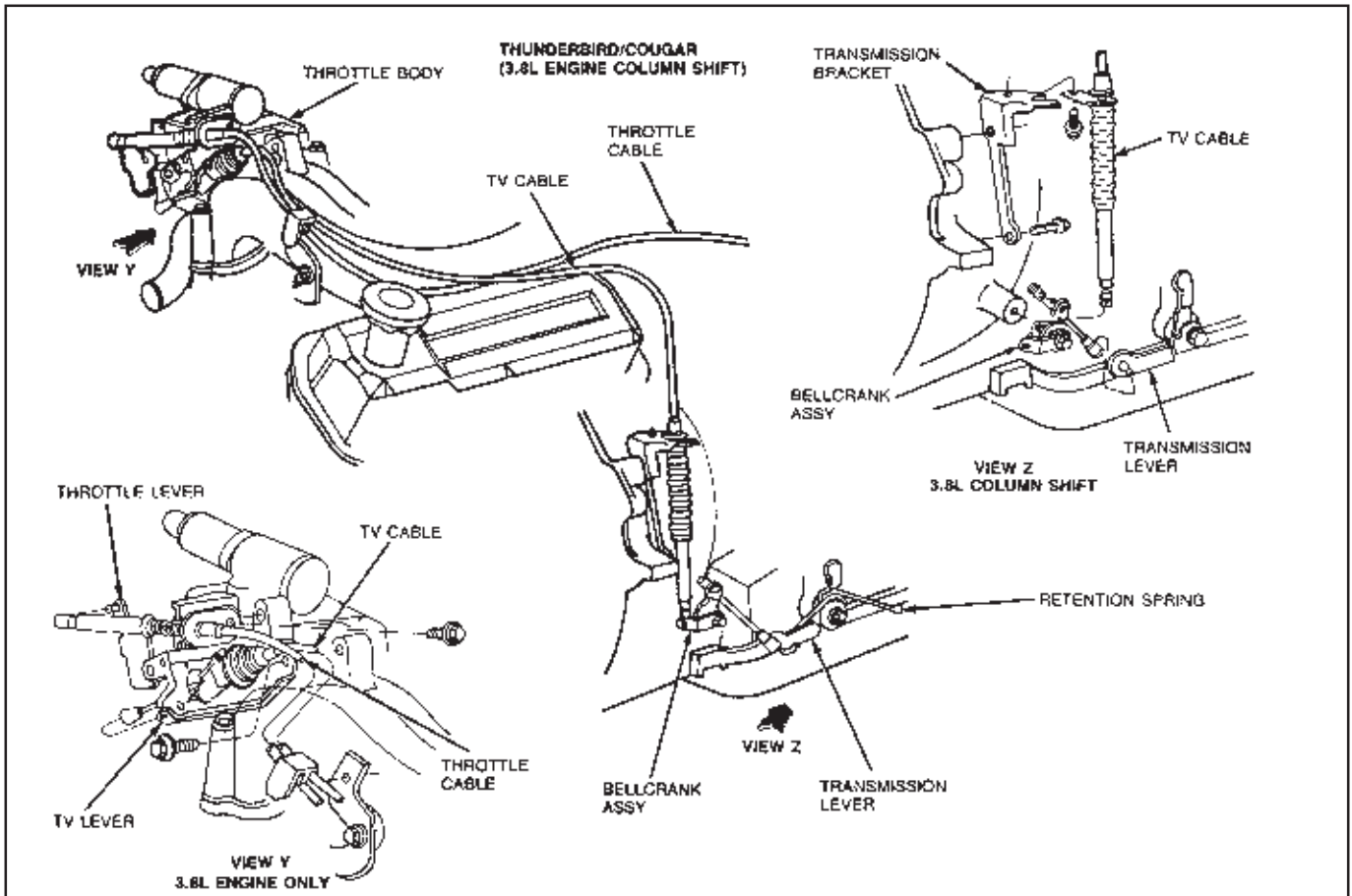

Figure 17

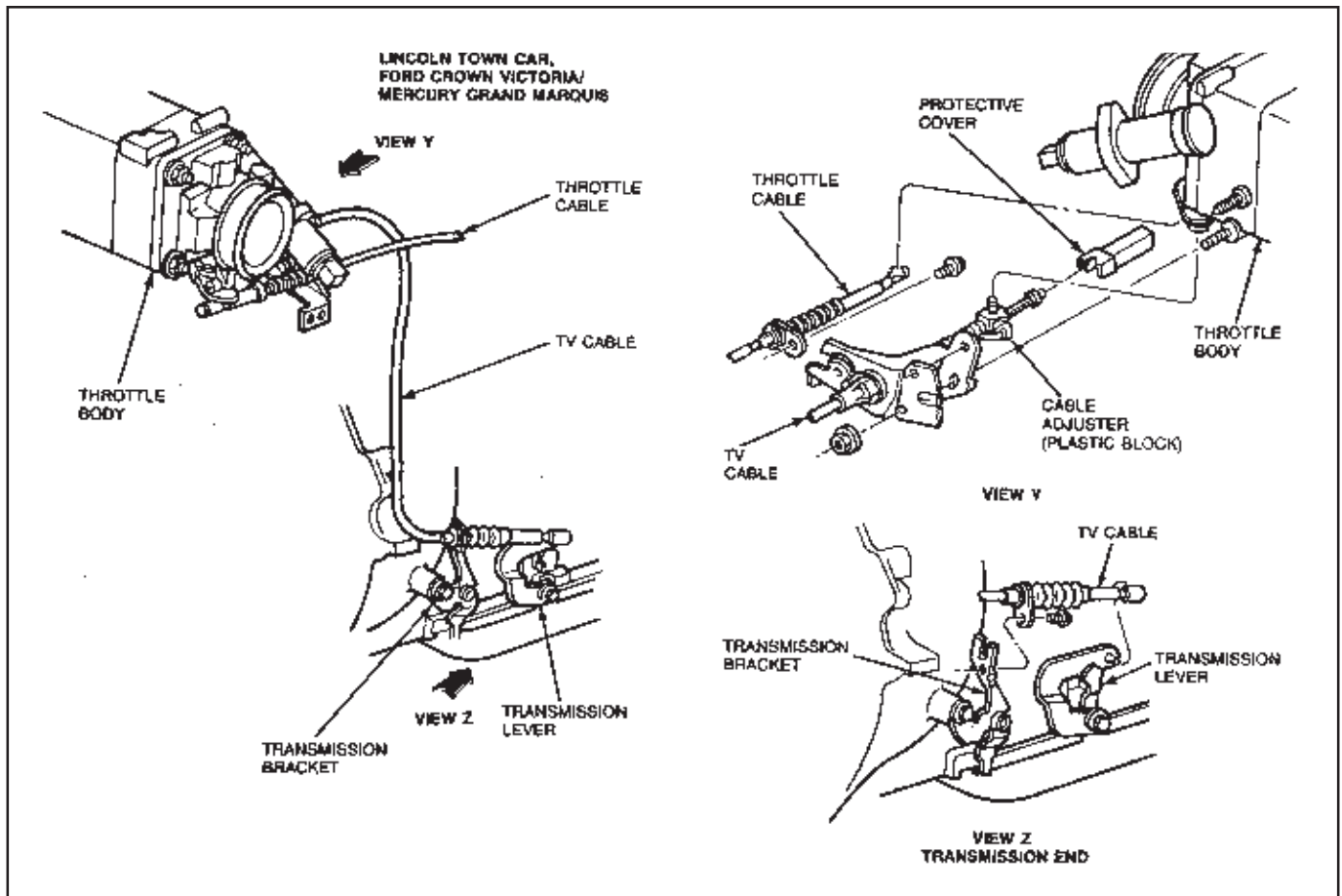

Figure 18

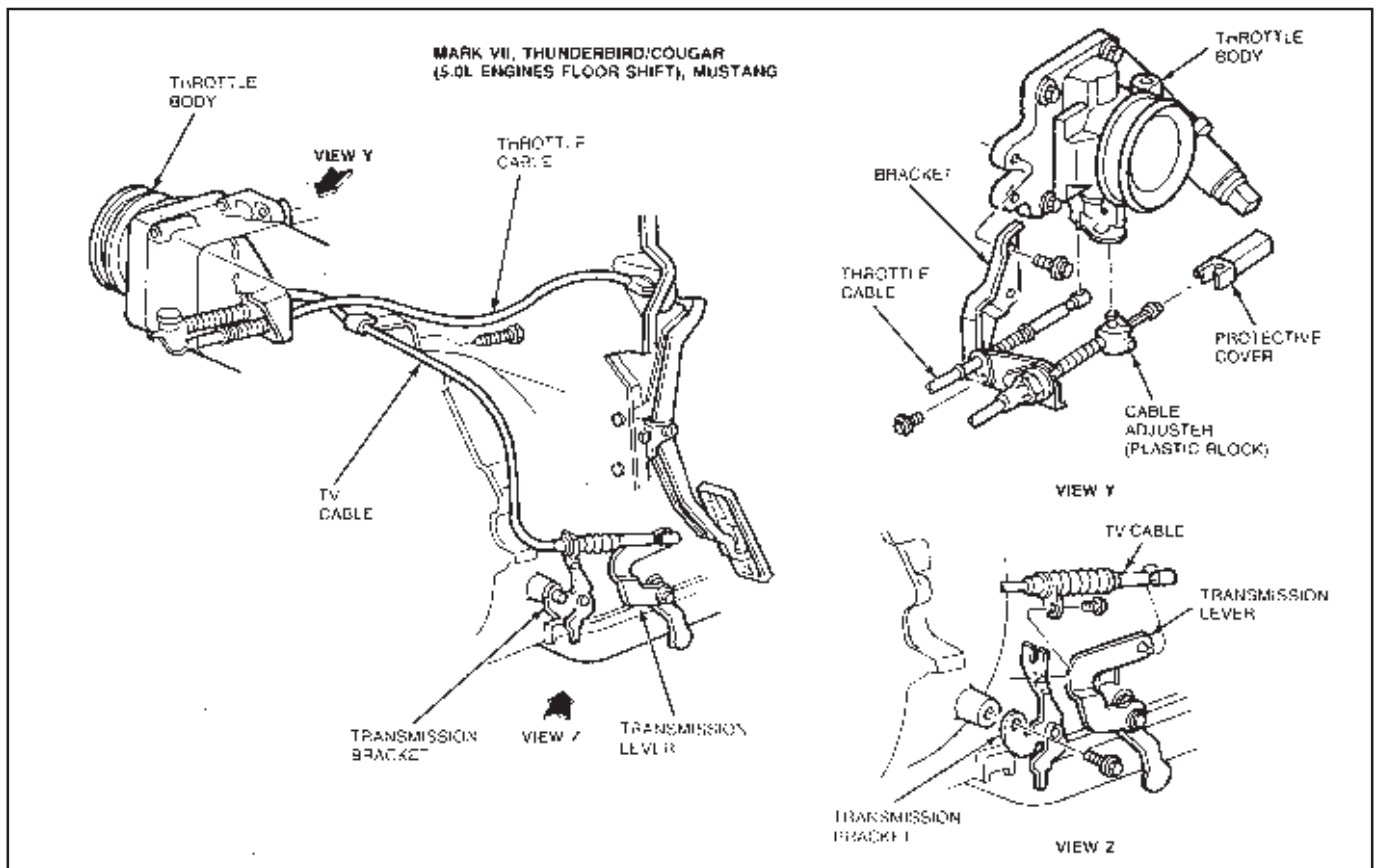

Figure 19

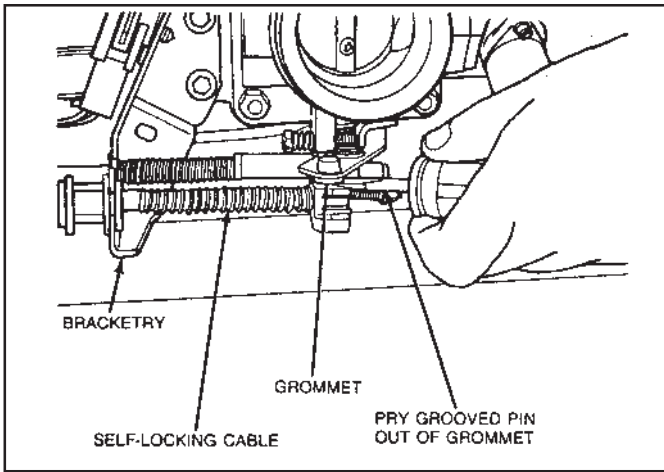

Figure 20

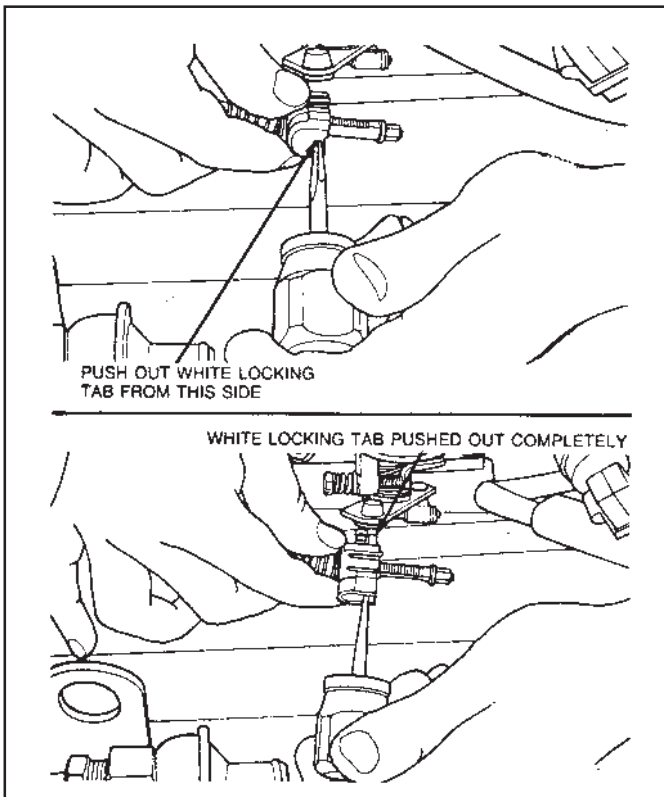

Figure 21

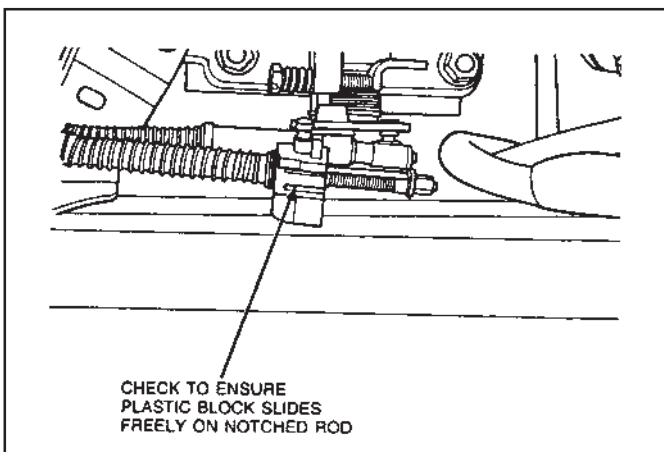

Figure 22

Under normal circumstances, it should not be necessary to alter or readjust the initial setting of the TV control cable. Situations requiring readjustment of the TV control cable include maintenance involving the removal and/or replacement of the throttle body, transmission, TV cable assembly or installing a new main control assembly. Readjustment of the TV control cable would also be necessary to correct complaints of poor transmission shift quality that would have been caused by a misadjustment of the TV control cable.

When the TV control cable is properly set, the transmission TV control lever will be at its internal idle stop (lever to rear as far as it will travel) when the throttle lever is at its idle stop.

Idle Speed Affect on TV Control Cable

The 5.0L and 5.0L HO (302 CID) SEFI engine uses an Air Bypass (ISC) that does not affect throttle position. Therefore, idle automatic setting does not affect TV cable adjustment.

6. Self-locking TV Cable Linkage Adjustment

- 6.1 Remove air cleaner cover and inlet tube from throttle body inlet to access throttle lever and cable assembly.
- 6.2 Using a wide-blade screwdriver, pry grooved pin on

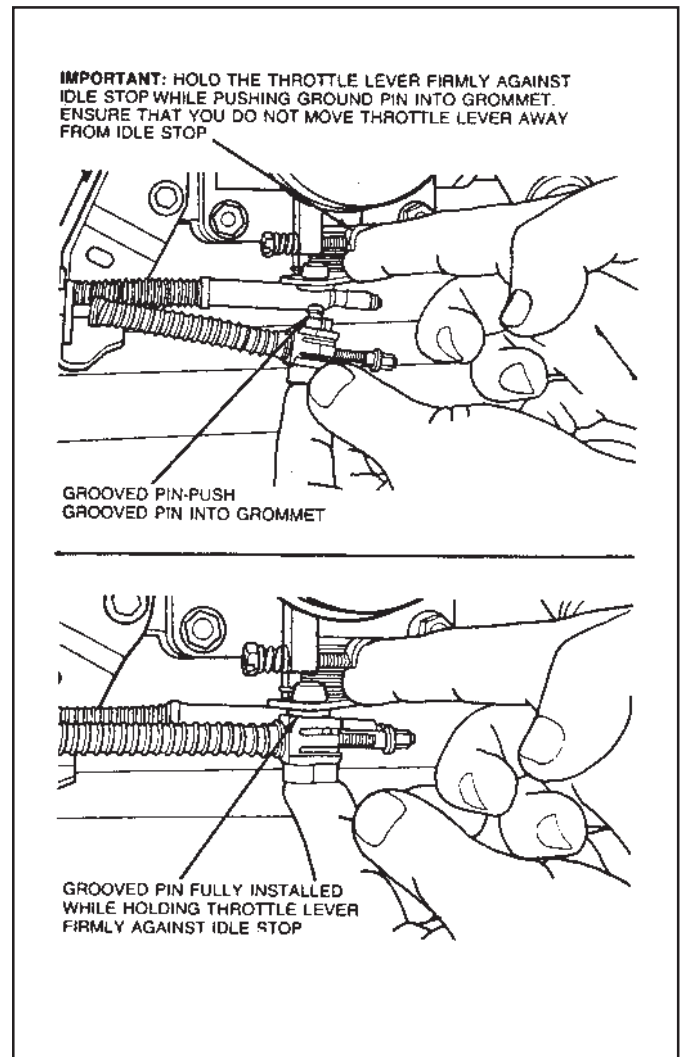

Figure 23

cable assembly out of grommet on throttle body lever. (See Fig. 20.)

- 6.3 Using a small screwdriver, push out white locking tab.
- 6.4 Check to ensure plastic block with pin and tab slides freely on notched rod. If it does not slide freely, the white tab may not be pushed out far enough. (See Figs. 21 & 22.)
- 6.5 While holding throttle lever firmly against its idle stop, push grooved pin into grommet on throttle lever as far as it will go. NOTE: While pushing pin into grommet, make sure you do not move throttle lever away from idle stop. (See Fig. 23.)

6.6 Install air cleaner cover and air inlet tube.

7. Self-locking TV cable adjustment using TV Control Pressure.

- 7.1 Attach TV pressure gauge (0-60 PSI) T86L-70002-A or equivalent to TV pressure tap (See Fig. 8).
- 7.2 Obtain Cable TV Gauge tool T86L-70332-A or equivalent.
- 7.3 Insert tapered end of the tool between the crimped slug on the end of cable and plastic notched rod, also on end of cable assembly. Push in Cable TV Gauge Tool T86L-70332-A or equivalent forcing the crimped slug

away from the plastic rod. Ensure gauge block is pushed in as far as it will go. (See Fig. 24.)

WARNING: THIS PROCEDURE REQUIRES WORKING IN CLOSE PROXIMITY TO THE EGR SPACER ASSEMBLY WHICH MAY BE HOT.

- 7.4 Operate engine until normal operating temperature is reached. The transmission fluid temperature should be approximately 38-72°C (100-150°F). Do not make pressure check if transmission fluid is cold or too hot to touch.
- 7.5 Set parking brake and place shift selector in NEUTRAL. With gauge tool in place and engine idling in NEUTRAL, the TV pressure should be between 207 and 276 kPa (30 and 40 psi). NOTE: Do not check or set TV pressure in PARK.
- 7.6 If TV pressure meets specification in Step 5, remove gauge tool allowing cable to return to its normal idle position. With engine still idling in NEUTRAL, TV

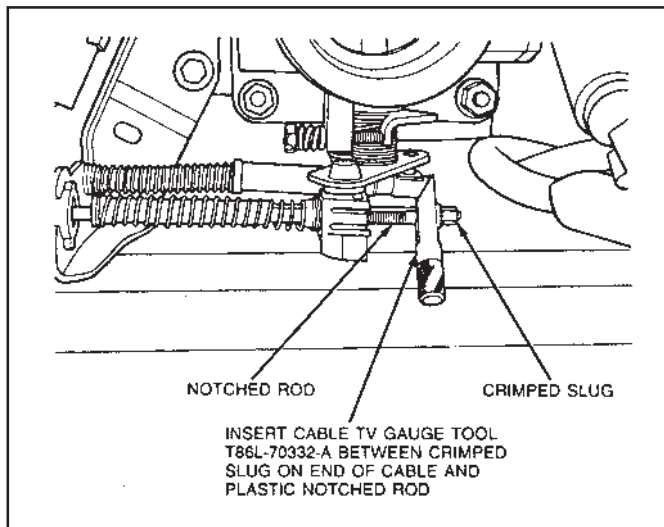

Figure 24

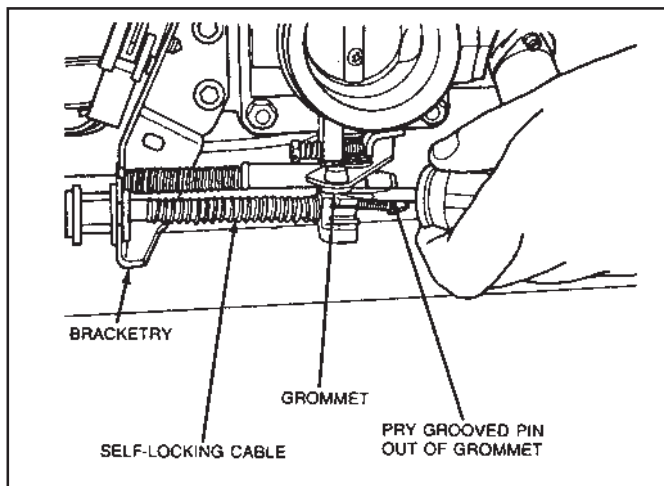

Figure 25

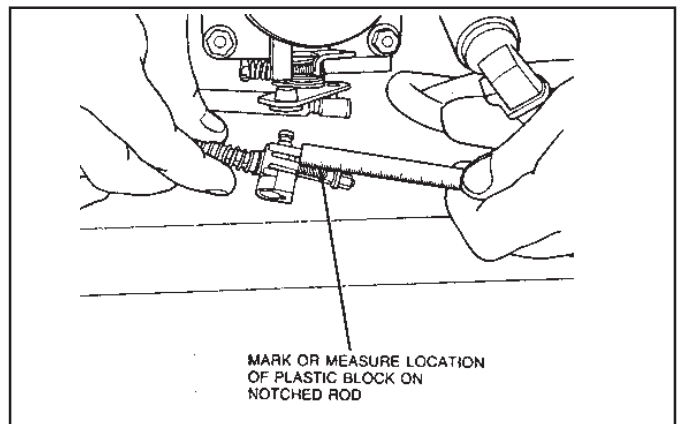

Figure 26

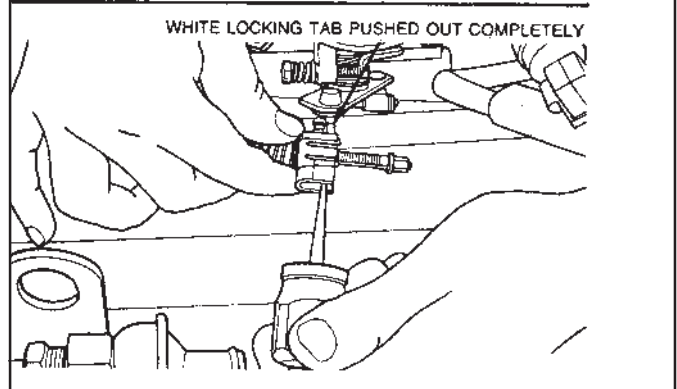
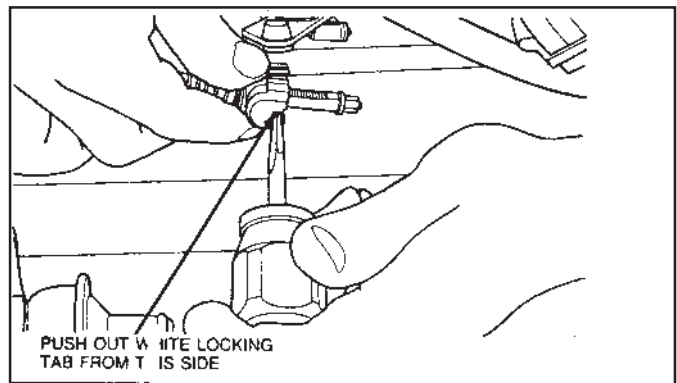

Figure 27

pressure must be at or near zero (less than 34 kPa (5 psi)).

- 7.7 If TV pressure does not meet specification in either or both Steps 5 and 6, remove gauge tool and readjust cable as outlined under Self-locking TV Cable Adjustment. Then repeat steps 3 through 6.
- 7.8 If TV pressure still does not meet specification, it will be necessary to modify adjustment as follows.
- 7.9 Remove gauge tool and pry grooved pin out of grommet on throttle lever. (See Fig. 25.)
- 7.10 Mark or measure location of plastic block on notched rod. (See Fig. 26.)
- 7.11 Push out locking tab. (See Fig. 27.)
- 7.12 Using mark or measurement on plastic block as a reference, move plastic block towards throttle body mounting bracket to raise TV pressure, or move it away from bracket to lower TV pressure. Push in white locking tab to lock block in position. (See Fig. 28.)
- 7.13 Insert grooved pin back into grommet. (See Fig. 29.)
- 7.14 Check TV pressure. Refer to Steps 3 through 6.

NOTE: For best transmission function, the TV pressure should be set as close as possible to 227 kPa (33 psi) in NEUTRAL with gauge tool installed. Since the TV pressure goes up approximately 14 kPa (2 psi) when the shift lever is moved from NEUTRAL to a forward gear, this will result in a TV pressure setting near the desirable 241 kPa (35 psi) in forward gear. **Do not attempt to check TV pressure with the transmission in gear.** When the gauge tool is removed, the TV pressure should drop to less than 34 kPa (5 psi). If the TV pressure does not drop to less than 34 kPa (5 psi), reset the TV pressure to a value less than 227 kPa (33 psi) with gauge tool installed but no less than 207 kPa (30 psi). Verify that the TV pressure is less than 34 kPa (5 psi) with gauge tool removed.

TOOL LIST

Hydraulic jack
 Gasket scraper
 Jack stands or Wheel ramps
 3/8" Drill motor
 Oil drain pan
 Fine cut flat file
 3/8" drive ratchet wrench
 Wet or Dry sand paper
 3/8" drive, 4" extension
 Grease or petroleum jelly
 8mm, 10mm, 13 mm, Sockets
 Needle nose pliers
 Torque wrench
 Small flat screwdriver
 Funnel

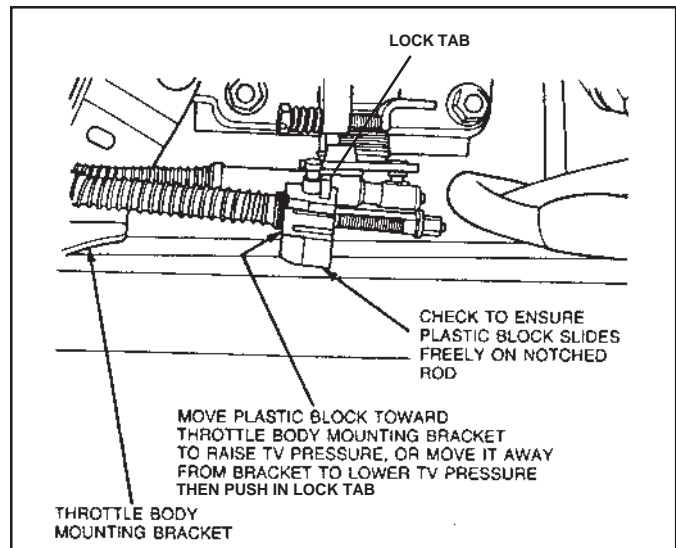

Figure 28

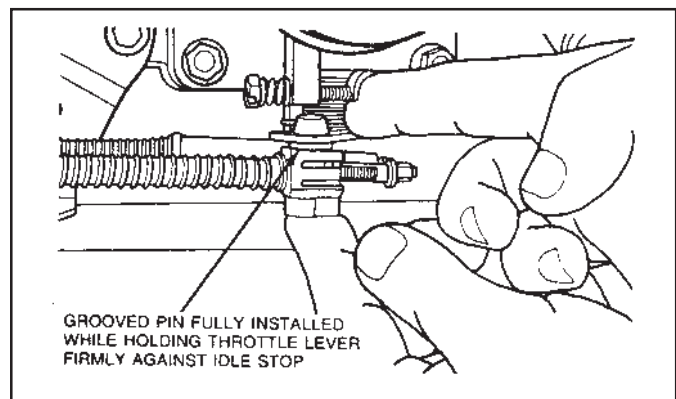

Figure 29

PARTS LIST

Separator plate		1
Spring, Red	Pressure regulator	1
Spring, Green	1-2 capacity modulator valve	1
Spring, Yellow	1-2 capacity modulator valve	1
Spring, blue	2-3 accumulator	1
Spacer, gold	2-3 accumulator	1
Seal ring	2-3 accumulator	1
Seal ring	2-3 accumulator	1
Drill	1/8"	1
Alignment pin		2
Screw	M4 X .7 X 10	1
Nut	M6 hex	2
Gasket	Plate to case	1
Gasket	Plate to valve body	1
Gasket	Oil pan	1
Gasket	Oil filter	1
Oil filter		1