



Wire Harness Installation Instructions

For Installing:

Part #20110

12 Circuit Chevy II / Nova (1966-'67)

Manual #90522



Perfect Performance Products, LLC

Painless Performance Products Division

2501 Ludelle Street

Fort Worth, TX 76105-1036

800-423-9696 phone • 817-244-4024 fax

Web Site: www.painlessperformance.com

E-Mail: painless@painlessperformance.com

We have attempted to provide you with as accurate instructions as possible, and are always concerned about corrections or improvements that can be made. If you have found any errors or omissions, or if you simply have comments or suggestions concerning these instructions, please write us at the address on the cover and let us know about them. Or, better yet, send us a fax at (817) 244-4024. We sincerely appreciate your business.

For Technical Questions

E-mail: tech@painlessperformance.com

Tech Line: 800-423-9696

Perfect Performance Products, LLC shall in no event be liable in contract or tort (including negligence) for special, indirect, incidental or consequential damages, such as, but not limited to, loss of property damage, or any other damages, costs or expenses which might be claimed as the result of the use or failure of the goods sold hereby, except only the cost of repair or replacement.

**P/N 90522 Painless Wiring Manual
July 2004**

Copyright © 2002 by Perfect Performance Products, LLC

NOTE :

If your vehicle has an existing harness, you will want to retain it for the possible re-use of various Pigtails & Connector housings, particular to your application.

Included in this kit is a sheet of pre-printed labels, to assist in identifying of connections as the existing harness is removed from the vehicle.

If you do not have an existing harness, there is a package of terminals included with the harness that will enable you to make most of the connections needed. Replacement lighting pigtails & sockets can be readily obtained from your local parts distributor

TABLE OF CONTENTS

List of Figures.....	ii
List of Tables.....	ii
1.0 Introduction.....	1
2.0 About These Instructions.....	1
3.0 Contents Of The Painless Performance Wire Harness Kit (Part #20110).....	2
4.0 Tools Needed.....	3
5.0 Removal of Original Wire Harness.....	3
6.0 Pre-installation and General Harness Routing Guidelines.....	4
7.0 General Harness Installation Instructions.....	4
7.1 Rough Installation.....	4
7.2 Terminal Installation and Making Connections	5
7.3 Grounding The Automobile.....	5
8.0 Harness Attachment by Section.....	6
8.1 Fuseblock Mounting.....	6
8.2 Tail/Dome Section Connections.....	7
8.3 Engine Section Connections.....	11
8.4 Headlight Section Connections.....	14
8.5 Dash Section Connections.....	15
9.0 Testing the System.....	19
10.0 Wire Connection Index and Fuse Requirements.....	19
10.1 Fuse Requirements.....	19
10.2 Wire Connection Index.....	20

LIST OF FIGURES

Figure 3.1	The Painless Performance Wire Harness Kit (Part #20110).....	2
Figure 5.1	Engine and Front Harness.....	3
Figure 5.2	Original Fuseblock.....	3
Figure 8.1	Pre-Routing Engine and Headlight Sections.....	6
Figure 8.2	Screws Securing Adapter Bracket.....	6
Figure 8.3	Fuseblock Mounted.....	7
Figure 8.4	Routing Dome Light Wires.....	7
Figure 8.5	Door Jamb Switch.....	8
Figure 8.6	Driver Kick Panel and Jamb Routing.....	8
Figure 8.7	Wire Routing in Trunk.....	9
Figure 8.8	Fuel Sender Wire Routing.....	9
Figure 8.9	License Plate Wire Routing.....	10
Figure 8.10	Backup and Brake/Tail Sockets.....	10
Figure 8.11	Wiper Motor and Engine Wire Routing.....	11
Figure 8.12	Wiper Motor Connections.....	11
Figure 8.13	Maxi Fuse.....	12
Figure 8.14	Electric Choke Connections.....	12
Figure 8.15	Alternator Connections.....	13
Figure 8.16	Brake Pressure Warning Switch Connection.....	13
Figure 8.17	Typical Fan Relay installation.....	14
Figure 8.18	Headlight and Park/Turn Light Wire Routing.....	14
Figure 8.19	Passenger Side headlight Wire Routing.....	15
Figure 8.20	Dimmer Switch Connection.....	15
Figure 8.21	Turn Switch Connector Removal.....	16
Figure 8.22	Turn Switch Connector Pin-out.....	16
Figure 8.23	Steering Column Covered for Protection.....	17
Figure 8.24	Instrument Panel Connections.....	17
Figure 8.25	Ignition Switch Connector.....	18

LIST OF TABLES

Table 10.1	Fuse Requirements.....	19
Table 10.2	Wire Connection Index.....	20

1.0 INTRODUCTION

You have purchased what we at Perfect Performance Products, LLC, believe to be the easiest to install automotive wire harness on the market. It is designed for easy installation, even if you have no electrical experience.

All kits have a built in anti-theft feature. Remove the fuse labeled "coil" from the fuse block; this will prevent the vehicle from starting.

The fuse block and fuses have been updated. The proper fuses have been pre-installed in the fuse block. In addition, all wires have been color-coded and printed. This will help you to identify the different circuits during installation and later if additions to the overall system are necessary. For fuse specifications and color designations, see **Section 10.0**.

In addition, all of our kits have "accessory" terminals at the front of the fuse block for your convenience. These terminals may be constantly hot or "switched" hot but all are non-fused.

This Painless Performance wire harness is designed to be used with a 1966-67 Chevy II/Nova. All of the wire in this kit is 600 volt, 125°c, TXL. Standard automotive wire is 300 volt, 80°c, GPT with PVC insulation.

This complete automobile wiring system has been designed with three major groups incorporated into it:

TAIL/DOME GROUP	Includes taillights, right and left turn signals, brake light, fuel tank sender and the dome light.
ENGINE GROUP	Includes starter solenoid, battery feed, alternator, voltage regulator, distributor, water temperature, oil pressure, and air conditioning.
HEADLIGHT GROUP	Includes high beam, low beam, park, right turn, electric fan, horn.
DASH GROUP	Includes wires to connect to indicator lights and switches to their proper sources.

2.0 ABOUT THESE INSTRUCTIONS

The contents of these instructions are divided into major **Sections**, as follows

- 1.0 Introduction**
- 2.0 About These Instructions**
- 3.0 Contents Of The Painless Performance Wire Harness Kit (Part #20110)**
- 4.0 Tools Needed**
- 5.0 Removal of Original Wire Harness**
- 6.0 Pre-installation and General Harness Routing Guidelines**
- 7.0 General Harness Installation Instructions**
- 8.0 Harness Attachment by Section**
- 9.0 Testing the System**
- 10.0 Wire Connection Index and Fuse Requirements**

Sections are divided into subsections and **Paragraphs**. Throughout these instructions, the **Figure** numbers refer to illustrations and the **Table** numbers refer to information in table form. These are located in Section and Paragraphs corresponding to the number. Always pay special and careful attention to any **Notes**, especially those in Tables, and any text marked **CAUTION**.

3.0 CONTENTS OF THE PAINLESS PERFORMANCE WIRE HARNESS KIT (PART #20110)

Refer to **Figure 3.1** to take inventory. See that you have all the parts you are suppose to have in this kit. If anything is missing, contact the dealer where you obtained the kit or Perfect Performance Products, L.L.C. at (817) 244-6898. This wire harness kit should contain the following items:

- The Main Wire Harness (with the fuseblock wired in and fuses installed)
- Tail Light Harness (plugged into main harness)
- Dome Light Harness (plugged into main harness)
- Fuseblock Mounting Plate
- Parts Kit (contains terminals, splices, and extra fuses)
- High Output Alternator Kit PP-662
- Maxi Fuse with holder and cover (in Bag Kit)
- Rubber Grommet (in Bag Kit)
- 2 packages of Nylon Tie Wraps (in Bag Kit)
- 2 Door Jamb Switches (in Bag Kit)
- 12 Instrument Panel Light Bulbs (in Bag Kit)
- 8 Harness Mounting Clamps (in Bag Kit)

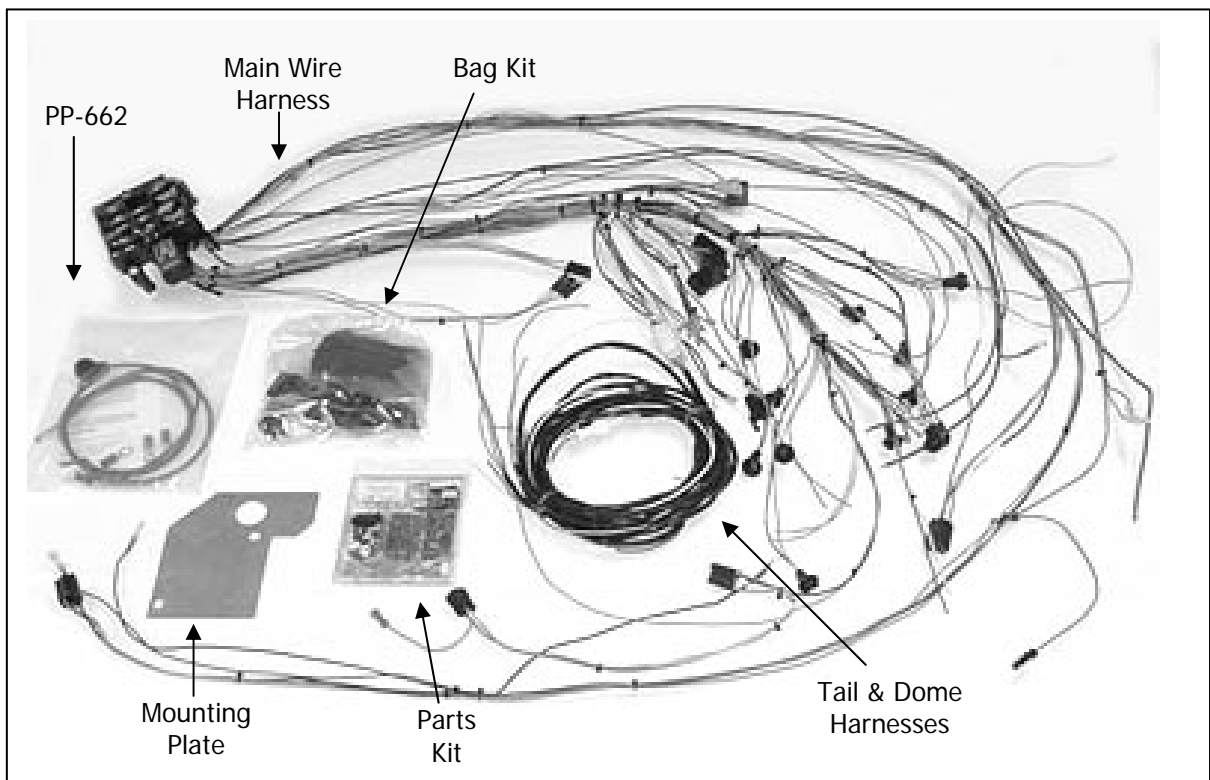

Figure 3.1 The Painless Performance Wire Harness Kit (Part #20110)

4.0 TOOLS NEEDED

In addition to your regular tools, you will need, at least, the following tools:

Crimper tool **Note: Use a quality tool to avoid over crimping**
Wire stripper
Test light or volt meter
Small (10 amp or less) battery charger

5.0 REMOVAL OF ORIGINAL WIRE HARNESS

5.0.1 Locate the engine and front harness and unplug them from the bulk head connector at the firewall. Disconnect the the other end of each of the wires and remove the harness from the vehicle.



Figure 5.1 Engine and Front Harness

5.0.2 Locate the two screws that secure the fuse block to the firewall and remove. Disconnect the wires from the dash cluster, switches and lights. Remove the door sill plate and kick panel on the driver's side floor for access to the wires going to the rear. Remove the rear light sockets and retain for reuse. Remove the rear harness from the vehicle.



Figure 5.2 Original Fuseblock

6.0 PRE-INSTALLATION AND GENERAL HARNESS ROUTING GUIDELINES

The installation mainly consists in two parts:

- The physical routing and securing of the wire harness, wires, and groups.
- The proper connection of the individual circuits.

These two major tasks are not separate steps, but are intergated together. That is, you will route wire and make some connections, route some more wires and make some more connections.

We can not tell you how to route your harness, but we can offer some guidelines. Pre-installation and general harness routing guidelines starting in Section 6.0, GENERAL installation instructions in Section 7.0, and precise instructions concerning the electrical connections you have to make, beginning in Section 8.0. Remember this harness was designed to be routed in the original manner.

To help you begin thinking through the installation of your new harness, read the following sections.

- 6.0.1** Familiarize yourself with your harness by locating each of the sections as listed in Table 10.2 Wire Connection Index on pages 20-22. (whenever a particular section is referred to in these instructions it is shown in " all caps": ENGINE SECTION A)
- 6.0.2** A good exercise is to lay out the wire harness on the floor next to your vehicle and identify all the SECTIONS. You will want to route the harness through and around open areas. Inside edges provide extra protection from hazards and also provides places for tie wraps, clips, and other supports.
- 6.0.3** Route the harness away from sharp edges, exhaust pipes, and hood, trunk, and door hinges.
- 6.0.4** Plan where harness will be located. Always allow enough slack at places where movement could occur (body to frame, frame to engine, ect.). Use a support every 12 inches unless the harness routes under the floor carpet.
- 6.0.5** At the wire ends don't depend on the terminals to support the harness. The weight could cause terminals to disconnect or copper wire strand to break.
- 6.0.6** The wire should be bundled in groups. Use tie wraps, convoluted split loom, or electrical tape for harness coverings.

7.0 GENERAL HARNESS INSTALLATION INSTRUCTIONS

7.1 ROUGH INSTALLATION

Note: *Harness routing and shaping is a time consuming task. Taking your time will enhance the beauty of your installation. Please be patient and TAKE YOUR TIME.*

- 7.1.1** Mold harness groups to the coutour of the floor pans, firewall, fender panels, and any other areas where wire or harness groups are routed. Remember to always route the harness away from sharp edges, exhaust pipes, hood and door hinges.

Note: *Do not tighten tie wraps and mounting devices at this time. Make all harness attachments LOOSELY.*

7.1.2 Attach harness groups to your vehicle with clips or ties (provided with this kit) starting at the fuse block and working your way out to the front and rear groups. The dash wires should be routed out of the way of any under dash obstacles, such as air conditioning, radio, etc.

7.1.3 When used every 1-1/2" or so on the visible areas of the harness, the plastic wire ties make a very attractive assembly. A tie wrap in other areas every 6" or so will hold the wires nicely. Convoluted loom also makes for an attractive assembly.

CAUTION: ***DISCONNECT THE POWER FROM YOUR VEHICLE BY REMOVING THE NEGATIVE BATTERY CABLE FROM THE BATTERY.***

Note: ***Make no wire connections or permanent mounting of any kind at this time!!!***

7.2 TERMINAL INSTALLATION AND MAKING CONNECTIONS

Note: ***In the following steps you will be making circuit connections. Before you start, you should carefully read Section 8 as appropriate, and continually refer to Section 10, DOUBLE-CHECKING your routing and length calculations before cutting any wires and making connections. Giving special attention to all switches.***

7.2.1 Have all needed tools and connectors handy.

7.2.2 Select the correct size for the wire and stud application.

7.2.3 Determine the correct wire length and cut the wire. Remember to always allow enough slack in the harness and wires at places where movement could possibly occur, such as automobile body to frame, frame to engine, ect. **Double-check your calculations.**

7.2.4 Strip insulation away from wire. Strip only enough necessary for the type of terminal lug you are using.

7.2.5 Crimp the terminal onto the wire.

Note: ***Make sure the terminal is crimped with the proper crimping tool. An improper crimp will NOT make a good connection.***

CAUTION: ***DO NOT OVER CRIMP***

7.2.6 Connecting the harness throughout the groups is a redundant process. Make sure that each wire is first properly routed and then attach. **DO NOT ATTACH FIRST THEN ROUTE AFTERWARD.**

7.2.7 When all wires are attached, tighten the mounts and ties to secure the harness permanently.

7.3 GROUNDING THE AUTOMOBILE

A perfectly and beautifully wired automobile will nevertheless have bugs and problems if everything is not properly grounded. Do not go to the careful effort of installing a quality harness only to neglect proper grounding.

7.3.1 Connect a Ground strap or Cable (even a 10-gauge is too small) from the Negative Battery terminal to the vehicle chassis (frame).

7.3.2 Connect a Ground Strap from the Engine to the Chassis. **DO NOT RELY UPON THE MOTOR MOUNTS TO MAKE THIS CONNECTION.**

7.3.3 Connect a Ground Strap from the Engine to the Body.

7.3.4 If you have a fiberglass body you should install a terminal block to ground all your gauges and accessories. Ground the Terminal Block and everything will be grounded.

Note: *Grounding straps may be purchased from most auto supply stores.*

8.0 HARNESS ATTACHMENT BY SECTION

8.1 FUSEBLOCK MOUNTING

8.1.1 Take the grommet provided and install into the hole in the adapter plate. Route the ENGINE and HEADLIGHT SECTIONS through the adaptor plate hole and firewall while bolting the fuseblock to the adapter plate, allowing the assembly to hang free.



Figure 8.1 Pre-Routing Engine and Headlight Sections

8.1.2 Route the DASH SECTION (ignition, instrument panel, headlight switch, etc) around the kick panel, over the steering column and the along the bottom the dash.

8.1.3 Position the fuseblock assembly so that the grommet is centered in the bulkhead hole. Using the 2 screws provided attach the fuseblock adapter plate to the firewall. See FIGURE 8.2 & 8.3

NOTE: *The fuseblock itself does not have to be grounded.*



Figure 8.2 Screws Securing Adapter Bracket

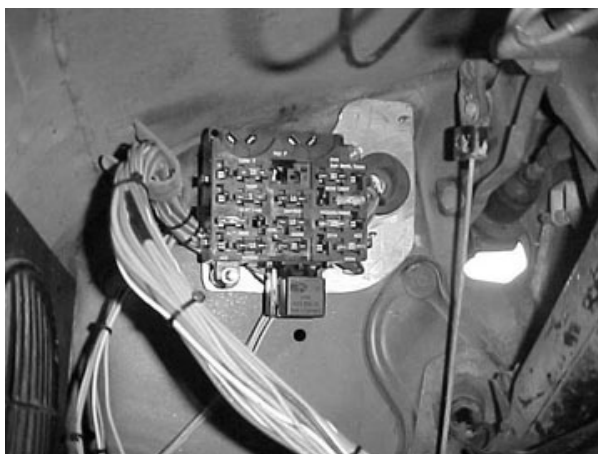

Figure 8.3 Fuseblock Mounted

8.2 TAIL/DOME SECTION CONNECTIONS

8.2.1 Take the DOME LIGHT SECTION and route it up from behind the drivers side kick panel, up through the A-Pillar over to the dome light. **NOTE: If your dome light wires are in good condition you can splice the new wires to the original ones in the kick panel area.**

8.2.2 Take the White wire on the Dome Light Harness and route it from the door jamb switch on the drivers side along the bottom of the dash to the passenger side door jamb switch. Connecting the white wires at the jamb switches and connecting the headlight switch connector (wire at headlight switch connector installed at factory) allows the dome light to be turned on when either of the doors are opened or the headlight switch knob is turned. **Note: New door jamb switches have been provided with the kit.**



Figure 8.4 Routing Dome Light Wires



Figure 8.5 Door Jamb Switch

- 8.2.3** Take the Tail Harness and route it from the drivers kick panel down the door jamb toward the rear of the vehicle. Routing the harness in between the rear seat and the body into the trunk. Once in the truck route the fuel sender wire to the fuel sender. Route the remaining harness over the fender and under the trunk opening. SEE FIGURE 8.7



Figure 8.6 Driver Kick Panel and Jamb Routing

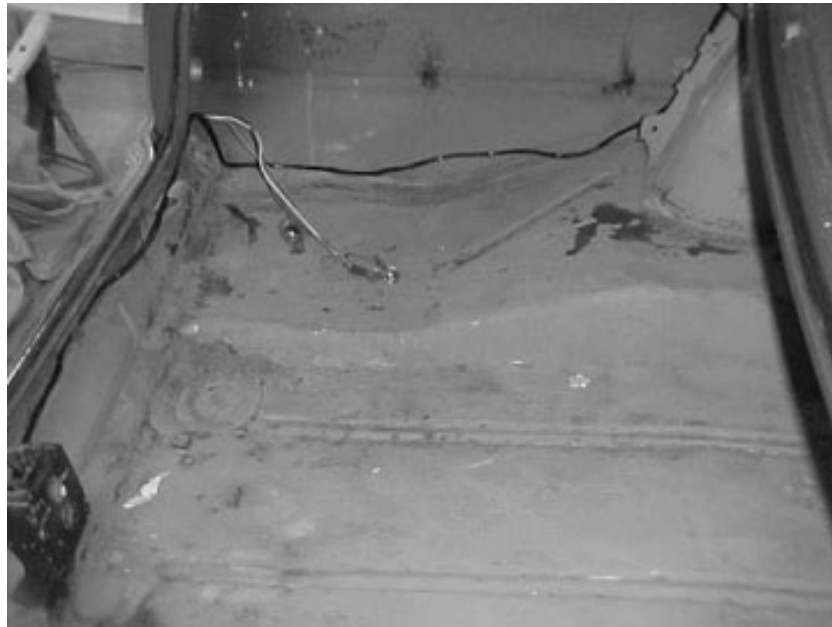

Figure 8.7 Wire Routing in Trunk

- 8.2.4** Locate the wire for the fuel sending unit and route it as shown in Figure 8.8. Connect the wire to the sending unit.

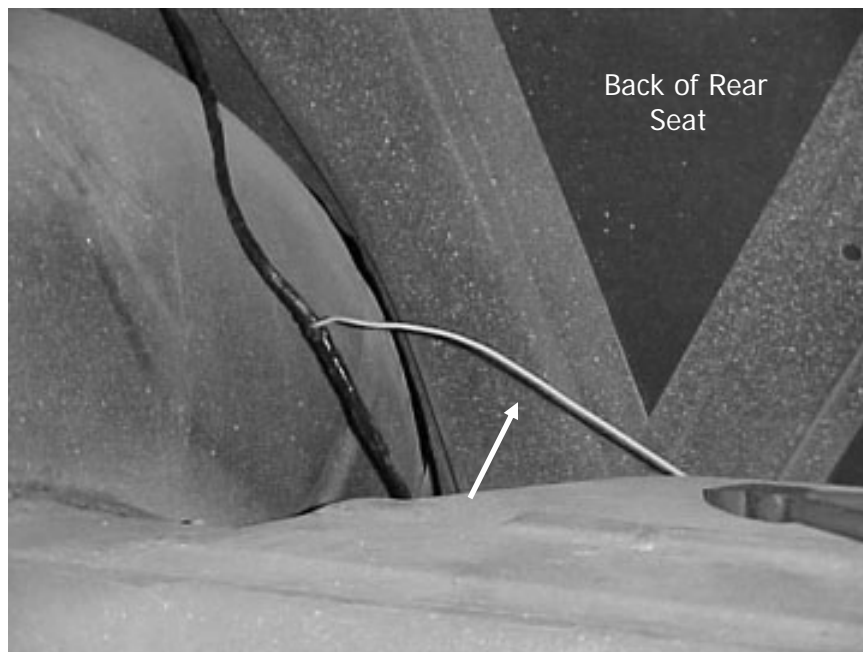

Figure 8.8 Fuel Sender Wire Routing

- 8.2.5** Locate the wire for the license plate light in the harness and route it through the grommet going out of the trunk. Connect the wire to the light.

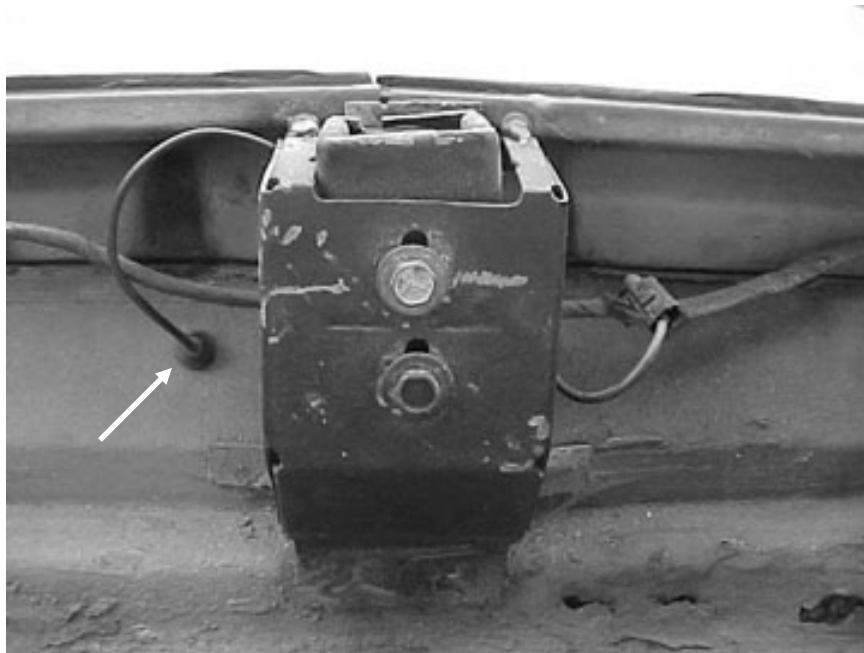

Figure 8.9 License Plate Light Wire Routing

- 8.2.6** Figure 8.10 shows the backup and brake/tail light sockets. You can remove the terminals from the sockets and solder the new wires to them or you can cut off the wire coming out of the sockets and splice to them using the supplied butt connectors.

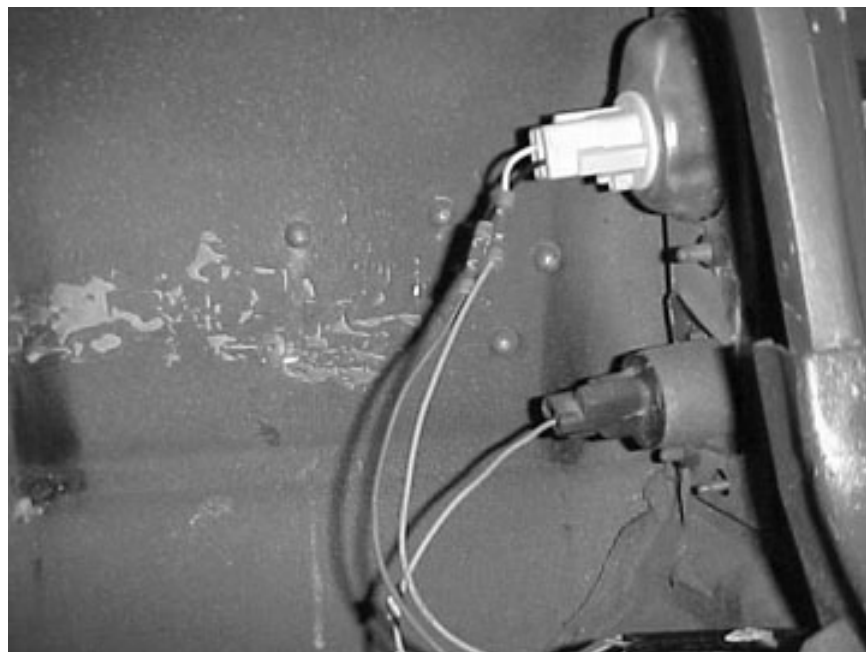

Figure 8.10 Backup and Brake/Tail Sockets

8.3 ENGINE SECTION CONNECTIONS

- 8.3.1** Route the wiper motor, coil, choke, temp sender, oil sender, starter, alternator and a/c compressor wires across the firewall to the wiper motor and to the engine.



Figure 8.11 Wiper Motor and Engine Wire Routing

NOTE: Included in the kit are 6 large harness securing clamps for the firewall and inner fender routing and 2 small clamp for headlight crossover wires.

- 8.3.2** Cut wiper motor wires to length, terminate and connect wires as shown in Figure 8.12

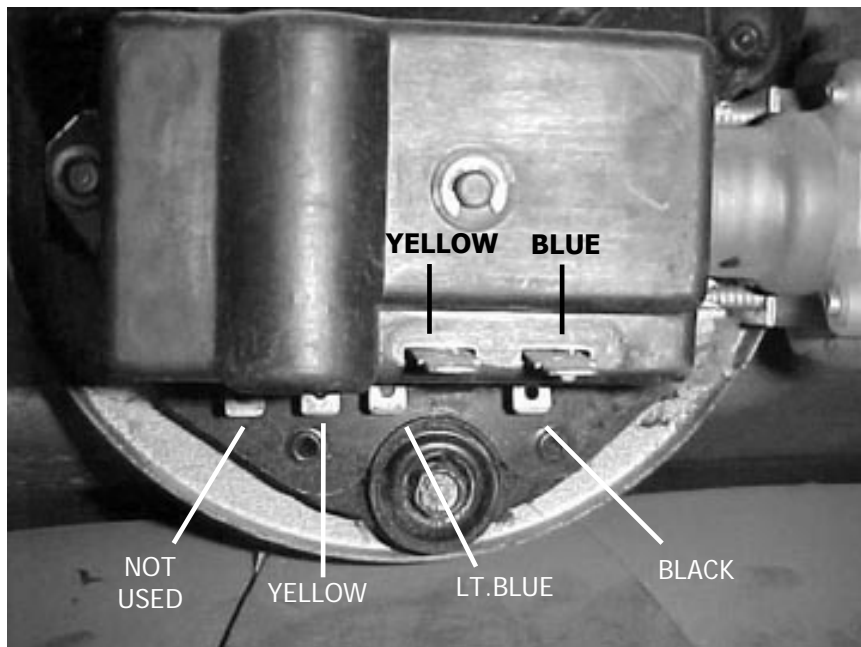

Figure 8.12 Wiper Motor Connections

8.3.3 Locate the maxi fuse holder and mount it to the passenger side inner fender panel as shown in figure 8.13. Take the starter Red wire (916) and route it to the maxi fuse holder. Cut the wire, crimp on a ring terminal and connect it to a fuse holder terminal. Take the remaining wire that was cut off and crimp on a ring terminal, connect it to the other side of the fuse holder. Take the other end and route it to the starter solenoid and connect it to the large battery terminal.

NOTE: If using an alternator larger than 65 Amps, you will need to review the instructions in the PP-662 ALTERNATOR WIRE KIT (supplied in bag in with this harness) before you make any maxi fuse or starter connections.

CAUTION: *TO PROTECT THE ENTIRE SYSTEM THE MAXI FUSE MUST BE INSTALLED AS INSTRUCTED.*

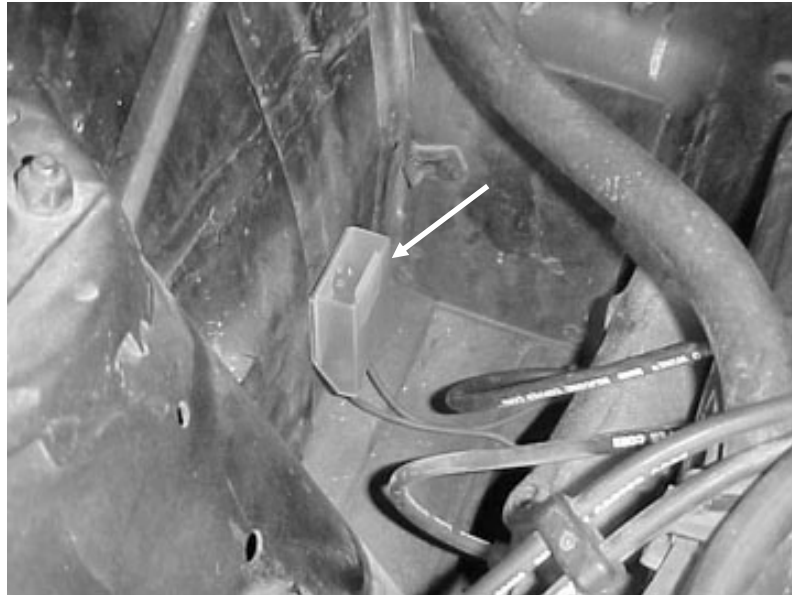

Figure 8.13 Maxi Fuse

8.3.4 Route and connect the starter, coil, oil sender, choke, temp sender, a/c compressor and alternator wires.

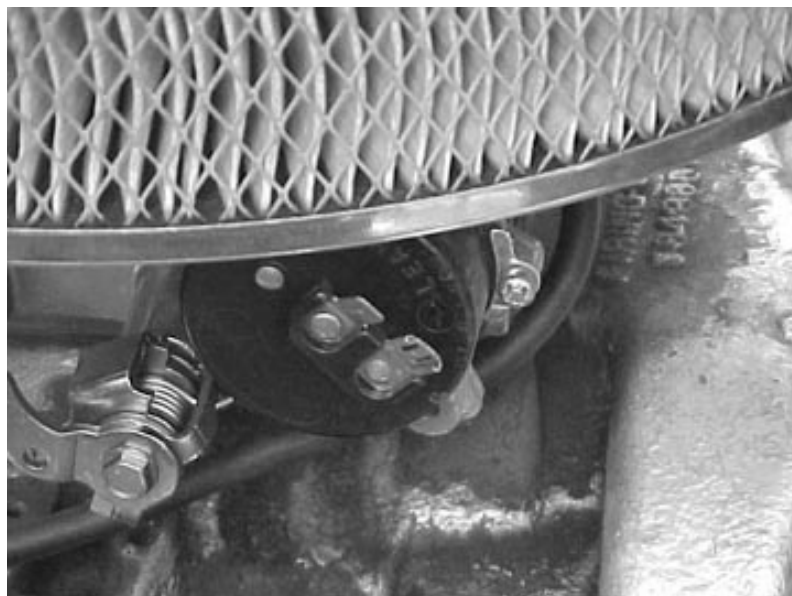

Figure 8.14 Electric Choke Connections

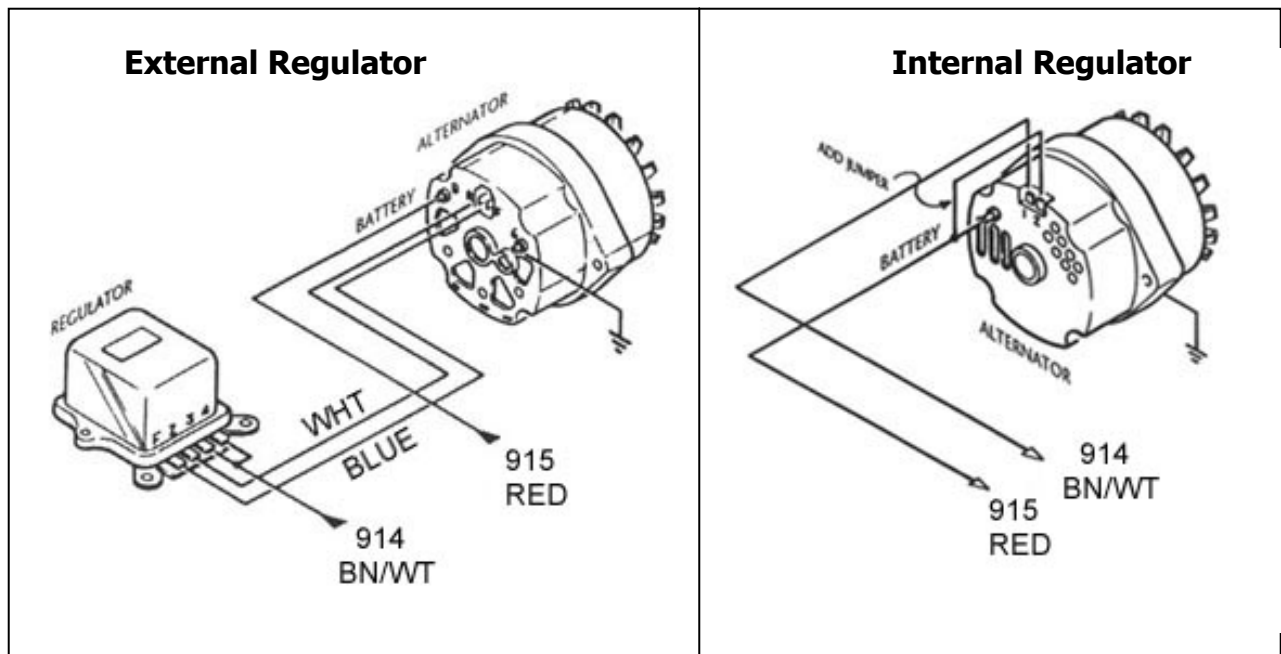

Figure 8.15 Alternator Connections

Note: In with the kit you should find a connector with a Blue and a White wire labeled "Alternator pigtail", this connector will be used as shown when using an external regulator system. If you have converted to a internal regulated system you will not need the alternator pigtail but will use the connector and terminals provided.

CAUTION : If using an alternator larger than 65 amps, you will need to use the PP-662 ALTERNATOR WIRE KIT supplied in a bag in the box. with this harness.

Note: *This will be used along with the alternator wires in the main harness.*

8.3.5 If you have a `67 model vehicle you will connect the brake pressure warning switch as shown below. The `66 model vehicle did not have a brake warning switch, you will tape and stow the wire.



Figure 8.16 Brake Pressure Warning Switch Connection

8.4 HEADLIGHT SECTION CONNECTIONS

- 8.4.1 Route the headlight, park light, horn and electric fan wires down the inner fender panel to the horn area. Secure the wires to the inner fender panel using the supplied clamps.
- 8.4.2 Connect the horn wires.
- 8.4.3 Take and route the headlight, park/turn and electric fan wires thru the core support and connect to the driver side lights and fan relay (if a electric fan is being used).

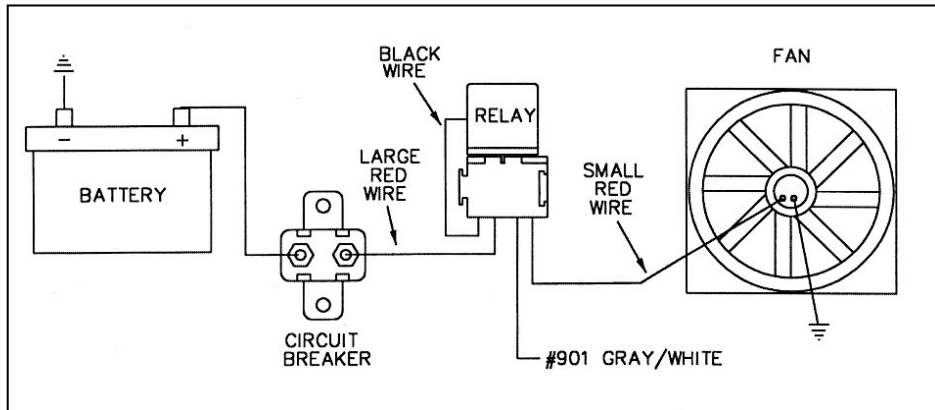

Figure 8.17 Typical Fan Relay Installation (**Painless Part #30101 Fan Relay Kit**)

- 8.4.4 Take the headlight ground ring terminal and ground it using one of the bolts in the core support.
- 8.4.5 Route the passenger headlight and park/turn wires across the front of the core support as shown. Use the two small clamps supplied to secure the wires.

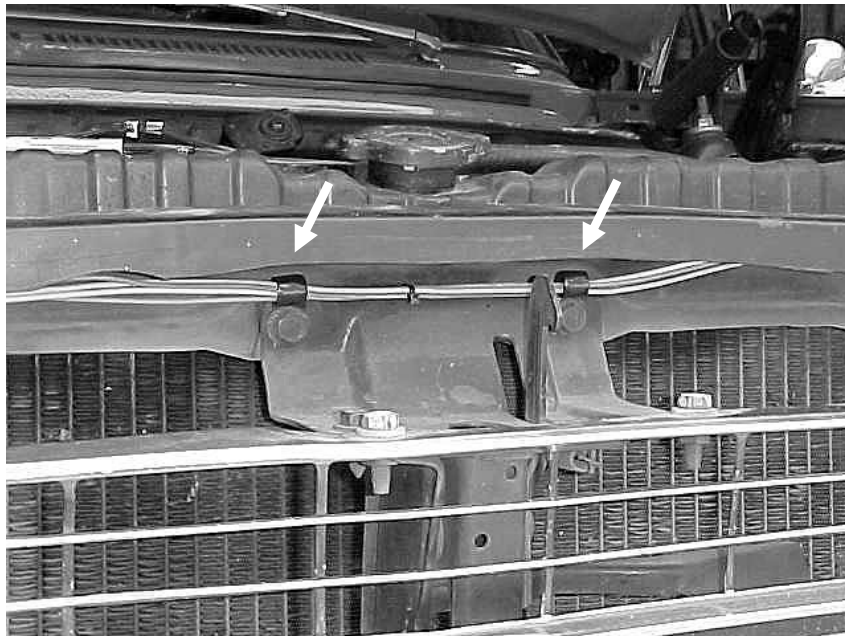

Figure 8.18 Headlight and Park/Turn Signal Wire Routing

- 8.4.6 On the Passenger-side of the core support you will find a hole (see arrow - Figure 8.19) in which you will route the park/turn signal wires through. Once you have routed the wires back through the core support, then route them down the side of the radiator to the park/turn signal light and connect. Route the headlight wires and connect.

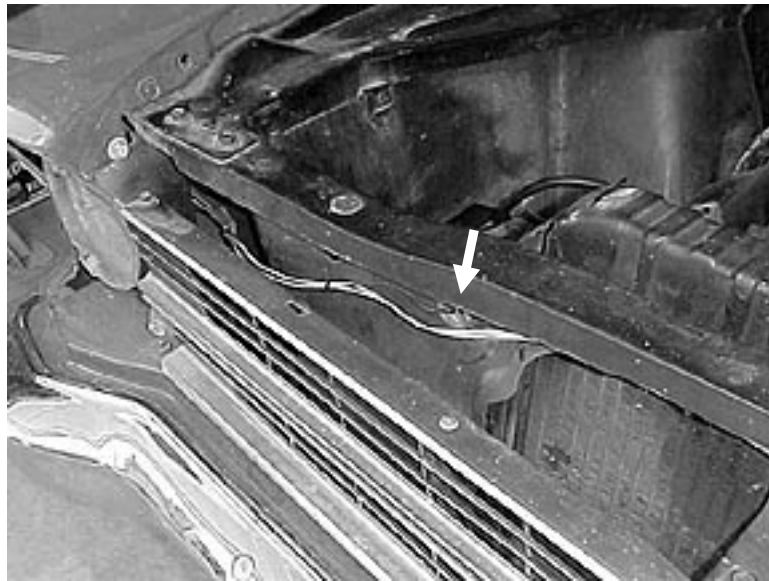

Figure 8.19 Passenger Side Headlight Wire Routing

- 8.4.7** Take the headlight ground ring terminal and ground it using one of the bolts in the core support.

8.5 DASH SECTION CONNECTIONS

- 8.5.1** Locate the connector for the dimmer switch and connect the switch.

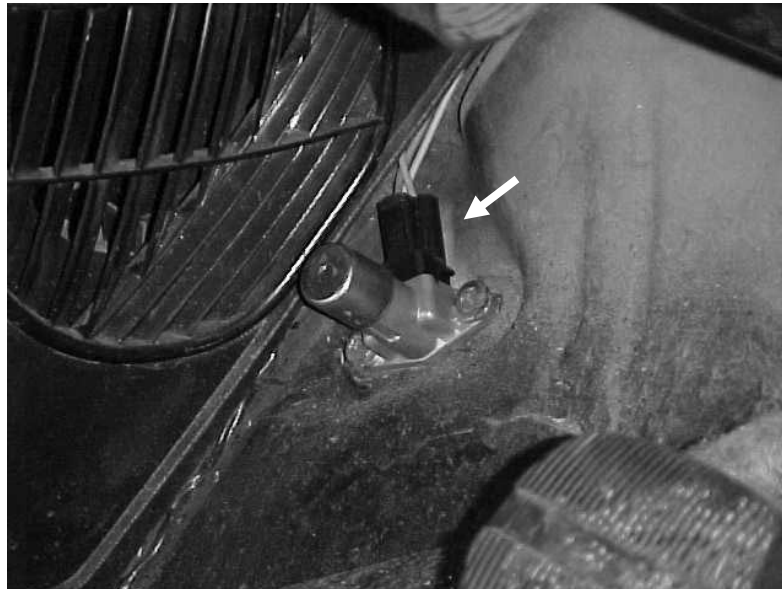

Figure 8.20 Dimmer Switch Connection (**Dimmer Switch – Painless Part #80150**)

- 8.5.2** If wiring a `67 model vehicle you will take the Tan wire labeled “Park Brake Swt” and connect it to the terminal on the parking brake assembly. This wire will not be used on the `66 model vehicle, you will tape and stow it.
- 8.5.3** On the base of the steering column you will find the backup switch. Take the backup switch connector and plug it into the switch.

8.5.4 You will need to remove and use the turn signal switch connector from the original harness on the new harness. With the face of the connector toward you locate the locking ear cutout on each side of the terminals (FIGURE 8.21). Using a small screwdriver or end of a paperclip push the locking ears in towards the sides of the terminal until the terminal is released and will pull out of the connector.

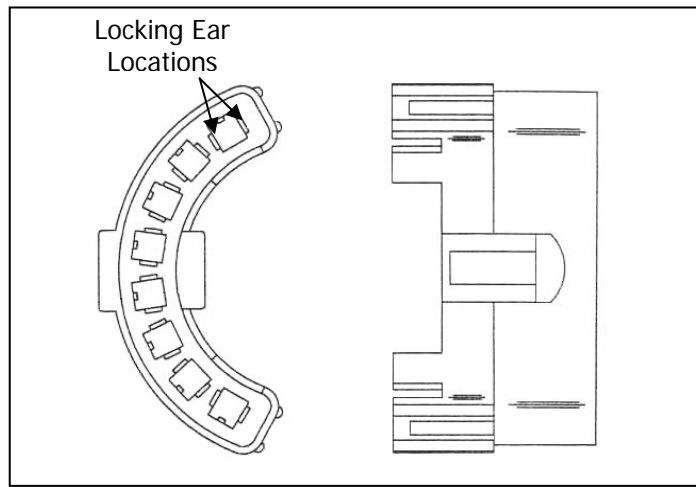

Figure 8.21 Turn Switch Connector Removal

8.5.5 Using one of the two illustrations below, insert the terminals from the new harness into the old turn signal connector. NOTE: When it is stated that the connector is viewed from the face view it is meaning that it will be showing it from the opposite side than the wires come out.

NOTE: The `66 connector is a 8-way connector and the `67 is a 9-way connector. The Brown wire will not be used with the `66 model turn switch, tape and stow it.

'66 CHEVY II / NOVA TURN SIGNAL CONNECTOR PINOUT		'67 CHEVY II / NOVA TURN SIGNAL CONNECTOR PINOUT	
			
A: GREEN	RT REAR TURN	A: WHITE	STOP SWITCH
B: YELLOW	LT REAR TURN	B: GREEN	RT REAR TURN
C: BLUE	RT FRONT TURN	C: YELLOW	LT REAR TURN
D: WHITE	STOP SWITCH	D: PURPLE	T/SIGNAL FLASHER
E: LT. BLUE	LT FRONT TURN	E: BROWN	EMERGENCY FLASHER
F: PURPLE	T/SIGNAL FLASHER	F: BLUE	RT FRONT TURN
G: BLACK	HORN	G: LT. BLUE	LT FRONT TURN
H: BLANK		H: BLACK	HORN
		I: BLANK	
<p>NOTES: THIS CONNECTOR IS VIEWED FROM FACE VIEW</p>		<p>NOTES: THIS CONNECTOR IS VIEWED FROM FACE VIEW</p>	

Figure 8.22 Turn Switch Connector Pin-out

- 8.5.6** Just down from the turn switch wires you will find the connector for the brake switch, take and connect it to the switch.
- 8.5.7** Locate the headlight switch connector and connect it to the switch.
- 8.5.8** Take the connector for the wiper switch and connect it to the switch.
- 8.5.9** Cover the steering column so it will be protected for the instrument panel removal as shown.

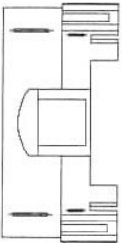
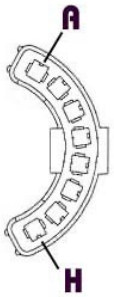
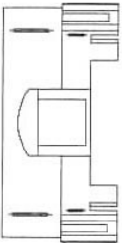
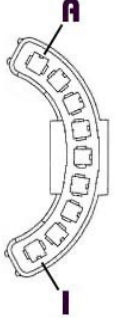
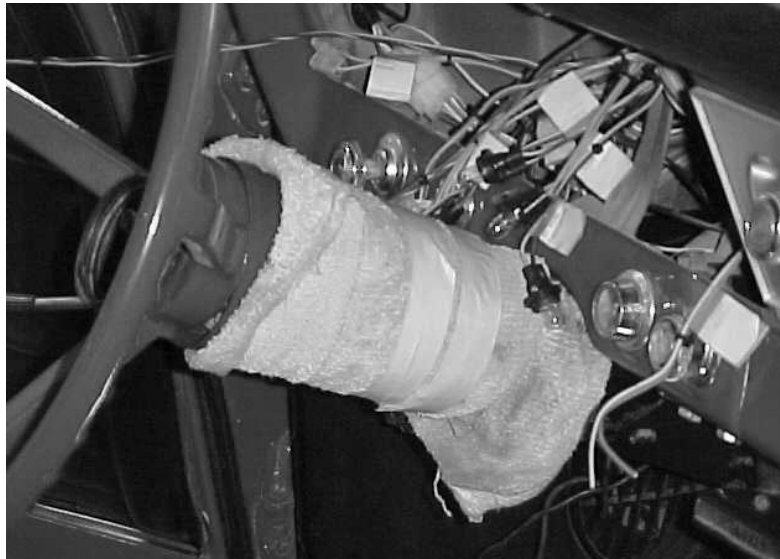
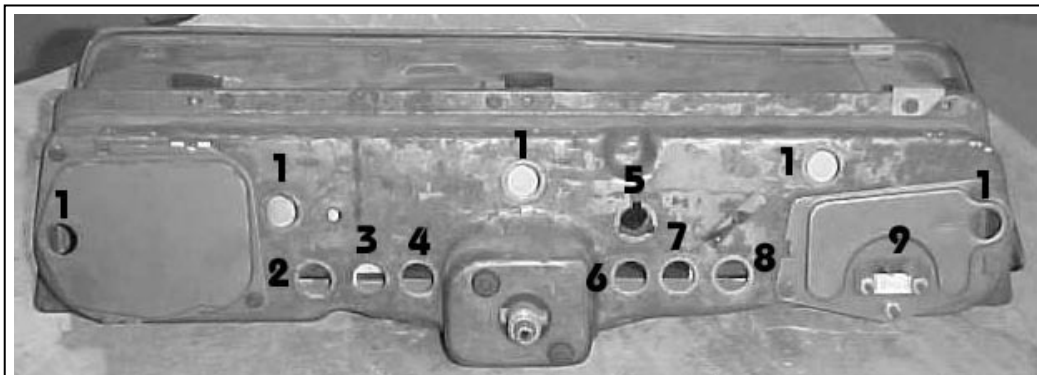

Figure 8.23 Steering Column Covered for Protection

- 8.5.10** Remove the screws securing the instrument panel to the dash and remove the instrument panel. Route the instrument panel wires out the opening in the dash.
NOTE: For dash cluster removal, the two bolts securing the steering column to the base of the dash must be removed and the column dropped down.
- 8.5.11** Install bulbs in the instrument panel light sockets. Using the illustration below plug-in the instrument panel lights and connector into the instrument panel.



'66-'67 Instrument Panel Connections

- 1: Dash Lights
- 2: Right Turn
- 3: High Beam (' 66)
Brake Warn (' 67)
- 4: Generator Light
- 5: High Beam (' 67 Only)
- 6: Temperature Light
- 7: Oil Pressure Light
- 8: Left Turn
- 9: Fuel Gage

Figure 8.24 Instrument Panel Connections

- 8.5.12** Reinstall the instrument panel.
- 8.5.13** Before re-installing the column drop collar, take and install the wire labeled "Ground" onto one of the bolts, then reinstall the bolts.
- 8.5.14** Take the Red #940 radio wire and connect it to the radio constant hot wire.
- 8.5.15** Connect the Yellow #941 wire to the radio wire that requires power only when the ignition switch is on.
- 8.5.16** IGNITION SWITCH SECTION, these wires have been pre-terminated with original type terminals. Refer to **Figure 8.25** for installation. YOU MUST USE YOUR OLD CONNECTOR.

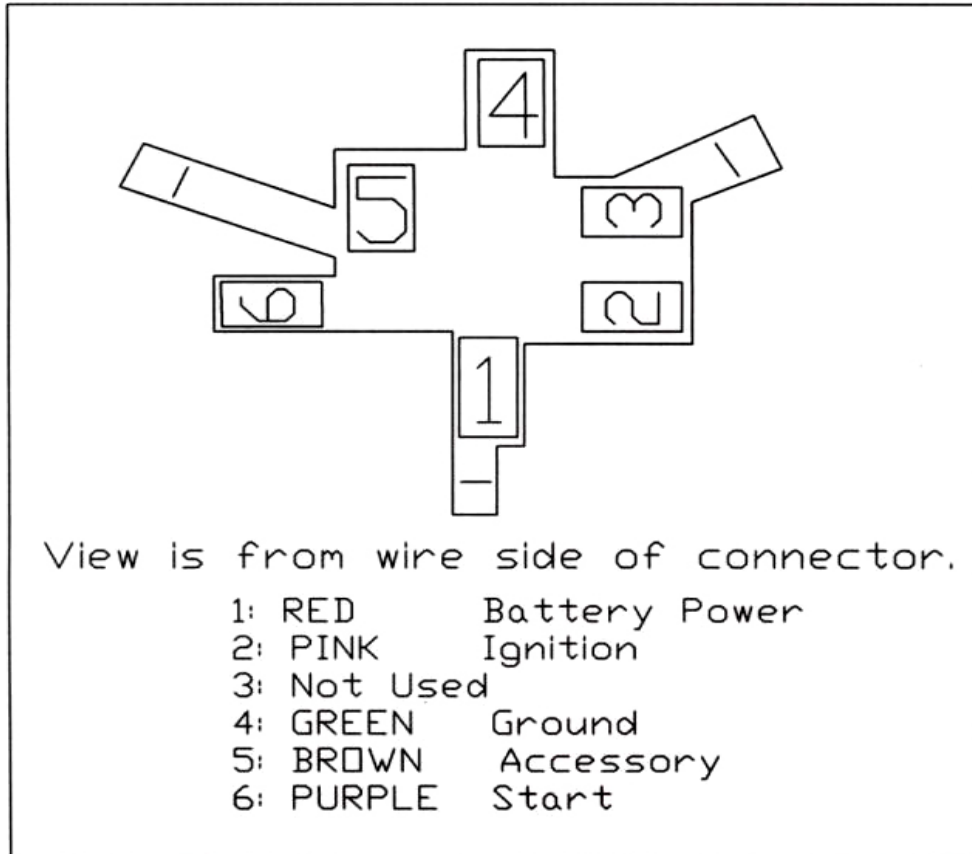

Figure 8.25 Ignition Switch Connector

- 8.5.17** Glove Box Light- This Org #980 wire routes along the bottom of the dash and up into the glove box through the light hole. Cut this wire to the proper length and then strip the wire. Take the glove box light and strip it also, then splice the wires together. Once you have spliced the wire you can reinstall the light. This wire is labeled "Glove Box"
- 8.5.18** Clock-Some models have a clock in the instrument panel, an Org #981 wire has been provided for power. Route this wire to the clock, then strip and terminate the wire with the proper terminal provided. Labeled "Clock"
- 8.5.19** Cigarette Lighter- This Org #903 wire has been preterminated for easy installation. Route the wire to the lighter and install. Labeled "Cigarette Lighter"
- 8.5.20** Locate the four wire connector labeled "Heater Switch" and connect it to the heater switch.
- 8.5.21** Take the three wire connector labeled "Resistor" and plug it into the blower motor resistor.
- 8.5.22** Connect the Org wire labeled "Heater Blower" to the blower motor.

9.0 TESTING THE SYSTEM

- 9.0.1** Use a small battery charger (10 amp or less) to power up the vehicle for circuit testing. If there is a problem anywhere, the battery charger's low amperage and internal circuit breaker will provide circuit protection.

CAUTION: ***IF YOU HAVE NOT YET DISCONNECTED THE BATTERY FROM THE AUTOMOBILE, DO SO NOW! DO NOT CONNECT THE BATTERY CHARGER WITH THE BATTERY CONNECTED.***

- 9.0.2** Connect the battery charger's **NEGATIVE** output to the automobile chassis or engine block and its **POSITIVE** output to the automobile's positive battery terminal.
- 9.0.3** **INDIVIDUALLY** turn on each light, ignition, wiper circuit, etc, and check for proper operation.
- 9.0.4** After all circuits are checked out **THEN** attach the battery cable to the battery for vehicle operation.

10.0 WIRE CONNECTION INDEX AND FUSE REQUIREMENTS

In each section, connect the wire, as identified by its wire color, to the appropriate item in the CONNECT TO column. Pay close attention to the **NOTES** in this section. Identified by small, raised number such as the one at the end of this sentence.¹

Table 10.2 is divided into sections that correspond to the sections of your wire harness, (ENGINE SECTION, DASH SECTION, TAIL SECTION, etc). The Index is divided vertically into six columns: COLOR, GA. NUMBER, CONNECT TO, STARTING POINT, and SECTION OF STARTING POINT.

The columns labeled "STARTING POINT" and "SECTION OF STARTING POINT" are for your reference ONLY. The items in these columns tell you where each originates and from which section of the harness.

The column "NO." contains a 900-series number that is used to identify various wires in the wiring diagrams that are a part of these instructions.

Many (but not all) of the numbers occur TWICE in this index. That is because you will be connecting BOTH ENDS of many of the particular wire segments. However, some wire segments are pre-connected at one end. For instance all wires originating from the fuse panel and certain other wires such as those originating from the horn relay, the dimmer switch, and the instrument panel section.

10.1 FUSE REQUIREMENTS

Headlight Switch	30
Emergency Flashers/Dome	25
Turn Signals	15
Gauges	15
AC/Heat	30
Horn	20
Wipers	15
Brake Switch	20
Electric Fan Relay	5
Coil	30
Radio Ignition (Switched)	10

Table 10.1 Fuse Requirements

10.2 WIRE CONNECTION INDEX

Color	Ga.	No.	Connect to	Wire Starting Point	Section of Starting Point
HEADLIGHT SECTION					
Grn	14	924	Horn	Horn Relay	Fuse Panel
LtGrn	14	908	High Beam	Dimmer Switch	Dimmer Switch Section
Tan	14	909	Low Beam	Dimmer Switch	Dimmer Switch Section
Blk	14	995	Ground	Headlight	Headlight Section
Gry/Wht	18	901	Fan Relay Activation	Fan Switch	Dash Section
Blu	16	925	RF Turn Signal	Turn Signal Switch	Turn Signal Switch Section
LtBlu	16	926	LF Turn Signal	Turn Signal Switch	Turn Signal Switch Section
Ppl	16	927	Front Park Lights	Headlight Switch	Headlight Switch Section
ENGINE SECTION					
Pnk	14	920	Coil Power	Fuse Panel	Fuse Panel
Grn	18	921	Temperature Sending Unit	Temperature Light	Instrument Panel Section
Blu	18	922	Oil Pressure Sending Unit	Oil Pressure Light	Instrument Panel Section
Tan ¹	16	962	Brake Pressure Switch	Brake Warn Light	Instrument Panel Section
Red	18	954	Electric Choke	Fuse Panel	Fuse Panel
ENGINE SECTION (STARTER SOLENOID)					
Red	10	916	Battery Positive or Starter Solenoid (Large Terminal)	Fuse Panel	Fuse Panel
Ppl	12	919	Starter Solenoid "S Term"	Ignition Switch Start	Ignition Switch Section
ALTERNATOR SECTION					
Brn/Wht	16	914	Alternator Excitor	Charging Light	Instrument Panel Section
Red	10	915	Alternator Output	Fuse Panel	Fuse Panel
DASH/COLUMN SECTION					
Gry/Wht	18	906	Cooling Fan Switch Power	Fuse Panel	Fuse Panel
Gry/Wht	18	901	Cooling Fan Switch	Fan Relay	Engine Section
Orn	14	917	Brake Switch Power	Fuse Panel	Fuse Panel
Wht	14	918	Brake Switch	Turn Signal Switch	Turn Signal Switch
Lt.Grn	16	956	Backup Switch	Tail Lights	Tail Light Section
Pnk	18	958	Backup Switch	Fuse Panel	Fuse Panel
Orn	18	903	Cigarette Lighter	Fuse Panel	Fuse Panel
Orn	18	980	Glove Box Light	Fuse Panel	Fuse Panel
Wht	18	974	Door Jamb Switches	Dome Light	Dome Light Section
Tan ¹	16	962	Emergency Brake Switch	Brake Warning Light	Instrument Panel Section
DIMMER SWITCH SECTION					
LtBlu	14	907	Dimmer Switch	Headlight Switch	Headlight Switch Section
LtGrn	14	908	Dimmer Switch	High Beam	Headlight Section
Tan	14	909	Dimmer Switch	Low Beam	Headlight Section

Table 10.2 Wire Connection Index (1 of 3)

Color	Ga.	No.	Connect to	Wire Starting Point	Section of Starting Point
			HEADLIGHT SWITCH SECTION		
Red/Blk ²	12	928	Headlight Switch Power	Fuse Panel	Fuse Panel
Orn ³	14	959	Headlight Switch Power	Fuse Panel	Fuse Panel
LtBlu	14	907	Headlight Switch	Dimmer Switch	Dimmer Switch Section
Brn	16	929	Headlight Switch	Tail Lights	Tail Section
Ppl	16	927	Headlight Switch	Park Lights	Headlight Section
Gry	18	930	Headlight Switch	Instrument Panel Lights	Instrument Panel Section
Wht	18	961	Headlight Switch	Dome Light	Dome Light Section
			IGNITION SWITCH SECTION		
Pnk	12	931	Ignition Switch Coil	Fuse Panel	Fuse Panel
Brn	12	933	Ignition Switch Accy.	Fuse Panel	Fuse Panel
Grn	18	921	Ignition Switch Ground	Temperature Light	Dash Section
Red	12	934	Ignition Switch Power	Fuse Panel	Fuse Panel
Ppl	12	919	Ignition Switch Start	Starter Solenoid	Engine Section (Starter Solenoid)
			TURN SIGNAL SWITCH SECTION		
Brn ¹	16	951	Emergency Flasher Switch Power	Emergency Flasher	Fuse Panel
Ppl	16	952	Turn Signal Switch Flasher Power	Turn Flasher	Fuse Panel
Blk	18	953	Horn Switch	Horn Relay	Fuse Panel
Grn	16	948	Turn Signal Switch	RR Turn Signal	Tail Section
Ylw	16	949	Turn Signal Switch	LR Turn Signal	Tail Section
Blu	16	925	Turn Signal Switch	RF Turn Signal	Headlight Section
Wht	14	918	Turn Signal Switch	Brake Switch	Dash Section
LtBlu	16	926	Turn Signal Switch	LF Turn Signal	Headlight Section
			HEATER SWITCH SECTION		
Brn	14	904	Heater Switch Power		
Orn	14	982	Heater Switch	Heater Resistor	Heater Resistor Section
LtBlu	16	983	Heater Switch	Heater Resistor	Heater Resistor Section
Ylw	16	984	Heater Switch	Heater Resistor	Heater Resistor Section
			HEATER RESISTOR SECTION		
Orn	14	982	Heater Resistor	Heater Switch	Heater Switch Section
Orn	14	992	Heater Resistor	Blower Motor	Heater Resistor section
LtBlu	16	983	Heater Resistor	Heater Switch	Heater Switch Section
Ylw	16	984	Heater Resistor	Heater Switch	Heater Switch Section

Table 10.2 Wire Connection Index (2 of 3)

Color	Ga.	No.	Connect to	Wire Starting Point	Section of Starting Point
			WIPER SWITCH SECTION		
Blu 4	18	986	Wiper Switch	Wiper Motor	Wiper Motor Section
LtBlu 4	18	987	Wiper Switch	Wiper Motor	Wiper Motor Section
Blk 4	18	988	Wiper Switch	Wiper Motor	Wiper Motor Section
			WIPER MOTOR SECTION		
Ylw	18	989	Wiper Motor Power	Fuse Panel	Fuse Panel
Blu	18	986	Wiper Motor	Wiper Switch	Wiper Switch Section
LtBlu	18	987	Wiper Motor	Wiper Switch	Wiper Switch Section
Blk	18	988	Wiper Motor	Wiper Switch	Wiper Switch Section
			INSTRUMENT PANEL SECTION		
Brn/Wht	16	970	Charge Light	Fuse Panel	Fuse Panel
Brn/Wht	16	914	Charge Light	Alternator	Alternator Section
LtGrn	18	936	High Beam Indicator	Dimmer Switch	Dimmer Switch Section
LtBlu	18	937	Left Turn Indicator	LF Turn Signal	Turn Signal Switch Section
Blu	18	938	Right Turn Indicator	RF Turn Signal	Turn Signal Switch Section
Gry	18	930	Instrument Panel Lighting	Headlight Switch	Headlight Switch Section
Tan	16	939	Fuel Gauge	Fuel Sending Unit	Tail Section
Grn	18	921	Temp. Light	Temp. Sending Unit	Engine Section
Blu	18	922	Oil Light	Oil Pres. Sending Unit	Engine Section
Orn	18	981	Clock Power	Fuse Panel	Fuse Panel
Blk/Wht	14	975	Ground	Instrument Panel	Instrument Panel Section
Tan ¹	18	962	Brake Warning Light	Pressure Switch & Emergency Brake	Engine & Dash Sections
			RADIO SECTION		
Red	16	940	Radio Power Unswitched	Fuse Panel	Fuse Panel
Ylw	18	941	Radio Power Switched	Fuse Panel	Fuse Panel
			DOME LIGHT SECTION		
Wht	18	961	Dome Light (Ground)	Headlight Switch	Headlight Switch Section
Orn	18	945	Dome Light (Power)	Fuse Panel	Fuse Panel
			TAIL SECTION		
Grn	16	948	RR Turn Signal	Turn Signal Switch	Turn Signal Switch Section
Ylw	16	949	LR Turn Signal	Turn Signal Switch	Turn Signal Switch Section
Tan	16	939	Fuel Sending Unit	Fuel Gauge	Instrument Panel Section
Brn	16	929	Tail Lights	Headlight Switch	Headlight Switch Section
Lt.Grn	16	956	Backup Lights	Backup Switch	Dash Section

Table 10.2 Wire Connection Index (3 of 3)

NOTES:

1. This wire is used only on the `67 model vehicle, if wiring a `66 model you will tape and stow this wire.
2. This wire is power for the portion of the headlight switch that goes out to the headlights and front parking lights.
3. This wire is power for the portion of the headlight switch that goes out to the instrument panel lights and the taillights.
4. See Diagram1,page 23 for connection instructions.

The wiper switch connector is no longer available. We have terminated the wiper switch wires with the correct terminals so that your original connector can be re-used.

Remove the old terminals by using a small screwdriver or paperclip in the slot at the top of the terminal closest to the center of the connector. Push the release tang (pin) in and pull the wire out from the opposite side.

Re-install the wires in the same order by color code configuration that was removed.

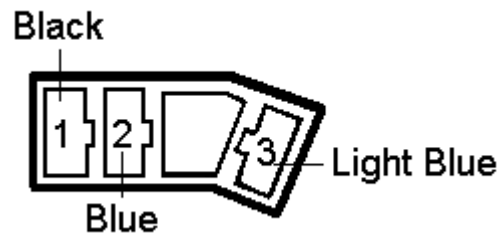

Diagram 1 Wiper Switch Connector

NOTES

Painless Performance Limited Warranty and Return Policy

Chassis harnesses, fuel injection harnesses and Striker ColdShot units are covered under a lifetime warranty.

All other products manufactured and/or sold by Painless Performance are warranted to the original purchaser to be free from defects in material and workmanship under normal use. Painless Performance will repair or replace defective products without charge during the first 12 months from the purchase date. No products will be considered for warranty without a copy of the purchase receipt showing the sellers name, address and date of purchase. You must return the product to the dealer you purchased it from to initiate warranty procedures.