



Wire Harness Installation Instructions

For Installing:

Part #20102 - GM Muscle Car Harness
18 circuit 1969 thru 1974



Manual #90552



**Painless Performance Products Division
Perfect Performance Products, LLC
2501 Ludelle St., Fort Worth, Texas 76105-1036
Phone (800) 423-9696**

We have attempted to provide you with as accurate instructions as possible, and are always concerned about corrections or improvements that can be made. If you have found any errors or omissions, or if you simply have comments or suggestions concerning these instructions, please write us at the address on the cover and let us know about them. Or, better yet, send us a fax at (817) 244-4024 or e-mail us at painless@painlessperformance.com. We sincerely appreciate your business.

Perfect Performance Products, LLC shall in no event be liable in contract or tort (including negligence) for special, indirect, incidental, or consequential damages, such as but not limited to, loss of property damage, or any other damages, costs or expenses which might be claimed as the result of the use or failure of the goods sold hereby, except only the cost of repair or replacement.

P/N 90551 Painless Wiring Manual August 2008

1st Edition August 2008

Copyright © 2008 by Perfect Performance Products, LLC

NOTE :

If your vehicle has an existing harness, you will want to retain it for the possible re-use of various Pigtails & Connector housings, particular to your application.

Included in this kit is a sheet of pre-printed labels to assist in identifying connections as the existing harness is removed from the vehicle.

If you do not have an existing harness, there is a package of terminals included with the harness that will enable you to make most of the connections needed. Replacement lighting pigtails & sockets can be readily obtained from your local parts distributor

NOTE:

Painless Performance has included 20 extra male and female bulkhead terminals in this harness kit. These may be used to add additional circuits using the male and female bulkhead connectors on the harness. See below for instructions on how to use these terminals. The terminals we have provided you are designed for wire gauges 18-14. Strip $\frac{1}{4}$ " of the insulation from the wire and then crimp it to the terminal using the correct terminal crimping tool. These terminals are **ROLL** crimp style. You can purchase this type of terminal crimper from your local Radio Shack. See below for a picture of the correct terminal crimping tool and how to use them. Take a look at how the terminals we inserted into the bulkhead connector here at the factory. Notice they are orientated a certain direction. Insert the blade (male) terminal into the engine compartment side bulkhead connector. Insert the female terminal into the passenger compartment side of the bulkhead connector.



TABLE OF CONTENTS

List of Figures.....	ii
List of Tables.....	ii
List of Diagrams.....	ii
1.0 Introduction.....	1
2.0 About These Instructions.....	1
3.0 Contents of The Painless Wire Harness Kit.....	2
4.0 Tools Needed.....	2
5.0 Pre-Installation and General Harness Routing Guidelines.....	2
6.0 Harness General Installation Instructions.....	4
6.1 Rough Installation.....	4
6.2 Harness Attachment.....	4
6.3 Grounding the Automobile.....	5
6.4 Terminal Installation and Making Connections.....	5
6.5 Testing the System.....	5
7.0 Specific Circuit Connections.....	6
7.1 Early GM Alternator (external regulator).....	6
7.2 Late GM Alternator (internal regulator).....	6
7.3 GM Ignition (Start/Run).....	8
8.0 Headlight section "A".....	9
9.0 Cooling Fan Relay Connection.....	10
10.0 Engine Section.....	10
11.0 Steering Column Wiring (Turn Signal & Ignition Switch).....	11
12.0 Ammeter and Maxi Fuse.....	12
12.2 Instrument Panel Wiring.....	13
12.3 A/C and Heat.....	13
13.0 Headlight Section "B".....	14
14.0 Interior Lighting.....	15
15.0 Brake Light Switch.....	15
16.0 Tail Section Wiring.....	15
17.0 Wire Connection and Fuse Requirements.....	18

LIST OF FIGURES

Figure 3.1	The Painless Wire Harness Kit.....	2
Figure 7.1	Early GM Alternator - External Regulator.....	6
Figure 7.2	Late GM Alternator - Internal Regulator.....	6
Figure 7.2A	High Output Wire.....	7
Figure 7.2B	GM CS-130 External Fan Alternator.....	8
Figure 7.2C	GM CS-130 Connector and Pin Out.....	8
Figure 7.2D	GM CS-130D Internal Fan Alternator.....	8
Figure 7.2E	GM CS-130D Connector and Pin Out.....	8
Figure 7.3	Maxi-Fuse.....	8
Figure 7.3A	GM Ignition System (Start/Run)	9
Figure 8.1	Headlight Section "A" wiring.....	9
Figure 9.1	Typical Fan Relay Installation	10
Figure 9.1A	Typical Fan Relay (with Thermostat).....	10
Figure 11.1	Ignition Switch and Turn Signal Switch Connection.....	11
Figure 12.1	Ammeter and Maxi-Fuse.....	12
Figure 12.2	Maxi Fuse.....	12
Figure 12.3	Heater/Blower Connection.....	13
Figure 13.1	Headlight Section "B" Wiring.....	14
Figure 13.2	Dimmer Switch.....	14
Figure 14.1	Interior Lighting.....	15
Figure 16.1	Integrated Brake Lights.....	17
Figure 16.2	Separate Brake/Turn Lights.....	17

LIST OF TABLES

Table 11.1	GM Ignition and Turn Signal Wiring.....	12
Table 17-1	Fuse Requirements.....	18
Table 17-2	Wire Connection Index (1 of 3).....	19
Table 17-2	Wire Connection Index (2 of 3).....	20
Table 17-2	Wire Connection Index (3 of 3).....	21

LIST OF DIAGRAMS

Diagram 1	Instrument Panel Section Wiring.....	22
Diagram 2	Engine Wiring.....	23
Diagram 3	Firewall Opening Template.....	24

1.0 INTRODUCTION

You have purchased what we at Painless Performance Products believe to be the most up-to-date and easiest-to-install automotive wire harness on the market. It is designed for easy installation, even if you have no electrical experience.

All kits have a built-in-anti-theft feature. Removing the fuse labeled "coil" from the fuse block will prevent the vehicle from starting.

The proper fuses have been pre-installed in the fuse block. In addition, all wires are color-coded. This will help you identify the different circuits during installation and later on if additions to the overall system are necessary. For fuse specifications and wire color designations, see **Section 17.0**.

In addition all of our kits have "accessory" terminals at the front of the fuse block for your convenience. These terminals may be constantly hot or "switched" hot but all are un-fused. If you plug into one of these terminals you must provide your own in-line fuse or circuit breaker.

The Painless wire harness is designed to be used in vehicles with a General Motors - keyed steering column, or other steering columns, depending on the kit purchased. All wire is 600 volt, 125°C, TXL. Standard automotive wire is GPT, 300 volt, 80°C, with PVC insulation.

This complete automobile wiring system has been designed with three major groups incorporated into it:

ENGINE/HEADLIGHT GROUP

Includes high beam, low beam, park, right turn, left turn, electric fan, horn, starter solenoid and battery feed, alternator and alternator exciter wire, distributor, water temperature, oil pressure, and air conditioning.

DASH GROUP

Includes wires to connect gauges, indicator lights, and switches to their proper sources. Trunk accessory, door locks, power windows, and electric fuel pump.

REAR LIGHT GROUP

Includes tail lights, dome lights (see Paragraph 14.1 & 14.2), left and right turn signals, brake lights, and fuel sender.

Installation requires four (4) easy steps:

1. Mount the fuse block
2. Route the wires
3. Cut off the excess wire
4. Terminate the wires

2.0 ABOUT THESE INSTRUCTIONS

The contents of these instructions are divided into major **Sections**, as follows:

- 1.0 Introduction
- 2.0 About These Instructions
- 3.0 Tools Needed
- 4.0 Contents of Painless Wire Harness Kit
- 5.0 Pre-Installation and General Harness Routing Guidelines
- 6.0 General Harness Installation Instructions
- 7.0 GM - Specific Circuit Connection Details
- 8.0 All Makes - Specific Circuit Connection Details
- 9.0 Wire Connection Index and Fuse Requirements

Sections are divided into subsections and **Paragraphs**. Throughout these instructions, the **Figure** numbers refer to illustrations and the **Table** numbers refer to information in table form. These are located in Sections or Paragraphs corresponding to the number. Always pay special and careful attention to any *Notes*, especially those in the Tables, and any text marked **Caution**.

3.0 CONTENTS OF THE PAINLESS WIRE HARNESS KIT

Refer to **Figure 3-1** to take inventory. See that you have everything you're supposed to have in this kit. If anything is missing, contact the dealer where you obtained the kit or Painless Performance at (800) 423-9696. The Painless Wire Harness Kit should contain the following items:

- A** The Main Wire Harness, with the Fuse Block wired in and fuses installed.
- B** Headlamp Connector Cables. (Extra Headlamp Cables are available separately under P/N 80300.)
- C** Maxi Fuse
- D** 2 Fender Well Grommets (for Headlamps)
- E** 2 packages of Nylon Tie Wraps
- F** 2 GM Turn Signal Connectors
- G** Parts Box, containing a GM Alternator Connector, Terminals, Splices, etc. This booklet, P/N 90552 Painless Wiring Manual.



Figure 3-1 The Painless Wire Harness Kit

4.0 TOOLS NEEDED

In addition to your regular tools, you will need, at least, the following tools:

- Crimping Tool *Note: Use a quality tool to avoid over-crimping.*
- Wire Stripper
- Test Light or Volt Meter
- Electric Drill
- 1-1/4" Hole Saw
- Small (10 amp or less) Battery Charger

5.0 PRE-INSTALLATION AND GENERAL HARNESS ROUTING GUIDELINES

The installation of your wire harness mainly consists in two parts:

- The physical routing and securing of the wire harness, wires, and groups.
- The proper connection of the individual circuits.

These two major tasks are not separate steps, but are integrated together. That is, you will route some wires and make some connections, route some more wire and make some more connections.

We cannot tell you how to physically route the harness in your automobile. That depends a great deal upon the particular make of automobile and to what extent you want to secure and conceal the harness. We do offer some general guidelines and routing practices starting in **Section 5.2**, GENERAL installation instructions in **Section 6.0**, and precise instructions concerning the electrical connections you will have to make in beginning in **Section 7.0**. To help you begin thinking through the installation of your wire harness, read the following sections:

- 5.1** Familiarize yourself with the harness by locating each of the harness sections in the following list. (Whenever a particular harness section is referred to in these instructions it is shown "all caps": ENGINE SECTION A.) Note that, according to the particular harness you have purchased, some of these sections may not be present, and some are not labeled:

ACCESSORY SECTION SWITCHES	HEADLIGHT SECTION A
ACCESSORY SECTION B+	HEADLIGHT SECTION B
DIMMER SWITCH SECTION	IGNITION SWITCH SECTION
DOOR SECTION A	INSTRUMENT PANEL SECTION
DOOR SECTION B	RADIO SECTION
ENGINE SECTION	SPEAKER SECTION
ENGINE SECTION (Single, 10 ga. red wire)	TAIL SECTION
ENGINE SECTION A	TURN SIGNAL SECTION

*Note: For complete information concerning the individual circuits and wires that make up the harness SECTIONS, see **Section 17.0**.*

- 5.2** The Painless Wire Harness is designed for the fuse block to be mounted in the stock location. The template on pg 31 is provided as a guide to check the existing cutout in the firewall for the bulkhead connector. Due to production tolerances, your opening may have to be modified slightly for optimum fitment. Please check before modifying your firewall.
- 5.3** Decide which of the following circuits you will be using in your system and where the harness groups or wires will be routed:

ROUTING LOCATION AND PLACEMENT

Emergency Flashers	
Horn	
Dome Lights	
Lights	
Power Windows	
Power Door Locks	
Cigarette Lighter	
Wipers	
Electric Fuel Pump	
Air Conditioner	
Electric Cooling Fan	
Coil	
Trunk Light	
Turn Signals	
Radio Ignition Switched Power	
Radio Constant Power	
Power Antenna	
Gauges	
Accessories	
Backup Lights	
Cruise Control	

5.4 Where will the following harness groups be routed?

Headlights	
Engine	
Dash	
Tail Lights	
Doors and Speakers	

- 5.5 A good exercise is to lay out the wire harness on the floor beside your automobile and identify all the SECTIONS. You will want to route the harness through and around open areas. Inside edges provide protection from hazards and also provide places for tie wraps, clips and other support.
- 5.6 Route the harness away from sharp edges, exhaust pipes, and hood, trunk and door hinges.
- 5.7 Plan where harness supports will be located. Allow enough slack at places where movement could occur (body to frame, frame to engine, etc.). Use a support every 12 inches unless the harness routes under the floor carpet.
- 5.8 At wire ends don't depend on the terminals to support the harness. The weight of the harness could cause terminals to disconnect or copper wire strands to break.
- 5.9 The wires should be bundled into groups. Use nylon ties, poly split loom, powerbraid, or tape.

6.0 **HARNES GENERAL INSTALLATION INSTRUCTIONS**

6.1 **Rough Installation**

CAUTION: DISCONNECT THE POWER FROM YOUR VEHICLE BY REMOVING THE NEGATIVE (BLACK) BATTERY CABLE FROM THE BATTERY.

Note: Make no wire connections or permanent mounting of any kind at this time!

- 6.1.1 Position the fuse block in its mounting area and secure .Use template provided on pg. 34 for fitment.
- 6.1.2 Route dash group (ACCESSORY SECTION B+ , ACCESSORY SECTION SWITCHES, HEADLIGHT SECTION B, INSTRUMENT PANEL SECTION and RADIO SECTION) upward to rear of dash and temporarily tie in place.
- 6.1.3 Install the forward section into the firewall mounted bulkhead connector. Screw the connector in place, but make NO connections under the hood at this time
- 6.1.4 Position rear group, consisting of DOOR SECTIONS A & B and SPEAKER SECTION - and TAIL SECTION, on floor pan area decided upon in **Sections 5.3 and 5.4**.

6.2 **Harness Attachment**

Note: Harness routing and shaping is and should be a time-consuming task. Taking your time will enhance the beauty of your installation. Please be patient and TAKE YOUR TIME!

- 6.2.1 Mold harness groups to the contour of floor pan, firewall, fender panels, and any other area where wires or harness groups are routed. Remember to route the harness away from sharp edges, exhaust pipes, hood, trunk and door hinges, etc.
- 6.2.2 Attach harness groups to your automobile with clips or ties starting at the fuse block, working out to the dash and along the floor pan for the rear group. The dash wires should be routed out of the way of any under-dash obstacles, such as cowl vent, air conditioning, radio, etc.

Note: Do not tighten tie wraps and mounting devices at this time. Make all harness attachments LOOSELY.

- 6.2.3 When used every 1-1/2" or so on the visible areas of the harness, the plastic wire ties make a very attractive assembly. A tie installed in other areas every 6" or so will hold the wires in place nicely. Remember to take your time!

6.3 Grounding the Automobile

A perfectly and beautifully wired automobile will nevertheless have bugs and problems if everything is not properly grounded. Do not go to the careful effort of installing a quality wire harness only to neglect proper grounding.

Note: The Painless Wire Harness Kit includes no ground wire except the black wire from the two headlamp connectors. You must supply ground wire (14-16 gauge) for all circuits.

- 6.3.1 Connect a Ground Strap or Cable (**2 GA Minimum**) from the Negative Battery terminal to the cylinder block.
- 6.3.2 Connect a Ground Strap from the Engine to the chassis. **DO NOT RELY UPON THE MOTOR MOUNTS TO MAKE THIS CONNECTION.**
- 6.3.3 Connect a Ground Strap from the Engine to the Body.

6.4 Terminal Installation and Making Connections

Note: In the following steps you will be making the circuit connections. Before you start, you should carefully read **Sections 7.0 through 10.0**, as appropriate, and continually refer to **Section 17.0, DOUBLE-CHECKING** your routing and length calculations before cutting any wires and making connections. Give special attention to Turn Signal and Ignition Switch connections. These can be somewhat confusing.

- 6.4.1 Have all needed tools and connectors handy.
- 6.4.2 Select the correct size terminal for the wire and stud application.
- 6.4.3 Determine the correct wire length and cut the wire. Remember to allow enough slack in the harness and wires at places where movement could possibly occur, such as automobile body to frame, frame to engine, etc. **Double-check your calculations.**
- 6.4.4 Strip insulation away from wire. Strip only enough necessary for the type of terminal lug you are using.

Note: In the following step, make sure that the terminal is crimped with the proper die in the crimping tool. An improper crimp will **NOT** make a good connection.

- 6.4.5 Crimp the terminal onto the wire.

CAUTION: DO NOT OVER-CRIMP!

- 6.4.6 Connecting the harness throughout the groups is a redundant process. Make sure that each wire is **FIRST** properly routed and **THEN** attach. **DO NOT ATTACH FIRST THEN ROUTE AFTERWARD.**
- 6.4.7 When all wires are attached, tighten the mounts and ties to secure harness permanently.

6.5 Testing The System

- 6.5.1 Use a small (10 amp or less) battery charger to power up the vehicle for circuit testing. If there is a problem anywhere, the battery charger's low amperage and internal circuit breaker will provide circuit protection.

CAUTION: IF YOU HAVE NOT YET DISCONNECTED THE BATTERY FROM THE AUTOMOBILE, DO SO NOW! DO NOT CONNECT THE BATTERY CHARGER WITH THE BATTERY CONNECTED.

Connect the battery charger's **NEGATIVE** output to the automobile chassis or engine block and its **POSITIVE** output to the automobile's positive battery terminal.

- 6.5.2 **INDIVIDUALLY** turn on each light, ignition, wiper circuit, etc. and check for proper operation.

Note: The turn signals will not flash properly if you do not have both the front and rear bulbs installed and connected.

- 6.5.3 When all circuits check out **THEN** attach the battery cable to the battery for vehicle operation.

7.0 SPECIFIC CIRCUIT CONNECTIONS

Note: Your alternator may not appear exactly as represented in the **Figures** below. The circuits are wired the same way, though.

7.1 Early GM Alternator - External Regulator. See Figure 7-1.

- 7.1.1 With a short 16-gauge jumper wire, connect Voltage Regulator terminals 3 & 4 together. Connect ENGINE SECTION wire #914 (wht) to Voltage Regulator terminal 3 or 4.
- 7.1.2 Connect ENGINE SECTION wire #915 (red) to the Alternator Output lug (Bat).
- 7.1.3 Connect a 14-gauge wire from Voltage Regulator terminal 2 to Alternator terminal R. Connect a 14-gauge wire from Voltage Regulator terminal F to Alternator terminal F.
- 7.1.4 Connect a 16-gauge ground wire from the Alternator Ground lug (G) to chassis ground.

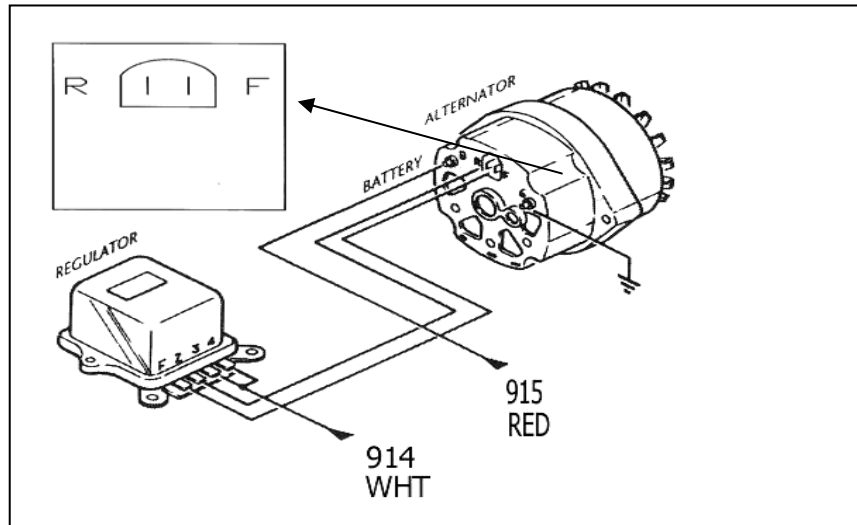

Figure 7-1 Early GM Alternator - External Regulator

7.2 Late GM Alternator - Internal Regulator. See Figure 7-2.

- 7.2.1 Connect ENGINE SECTION wire #914 (wht) to Alternator terminal 1. Connect ENGINE SECTION wire #915 (red) to the Alternator Output lug (Bat).
- 7.2.2 Connect a short 14-gauge jumper wire from Alternator terminal 2 to the Alternator Output lug (Bat).
- 7.2.3 A connector and terminal spades for late GM Alternators are included in the parts box.

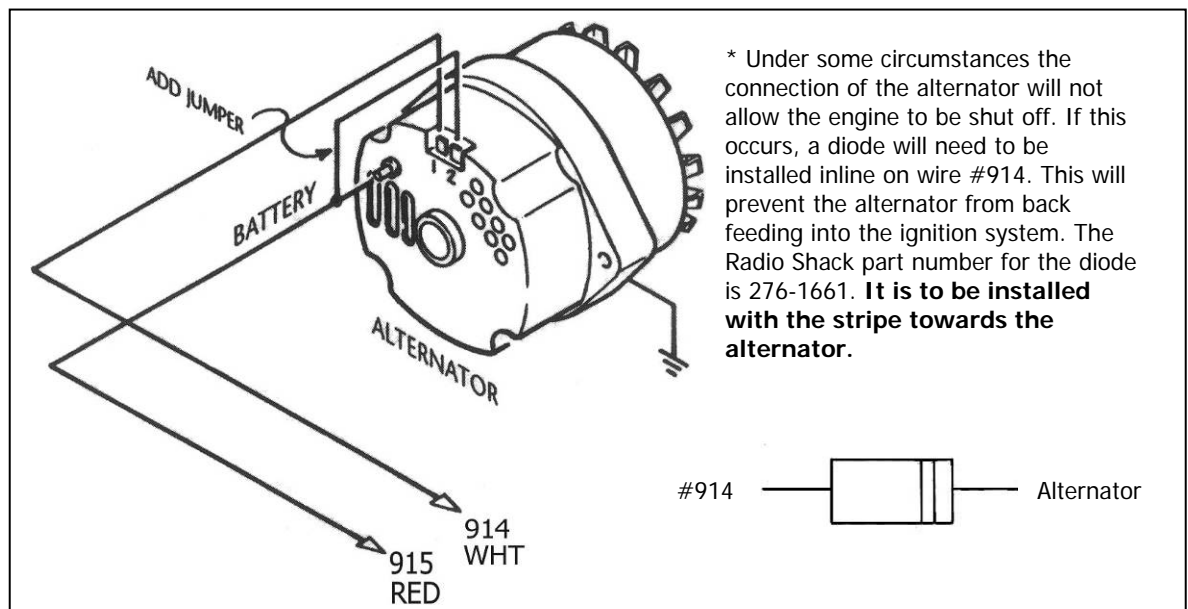

Figure 7-2 Late GM Alternator - Internal Regulator

GM One-Wire Alternator.

- 7.2.4 Connect ENGINE SECTION wire #915 (red) to the Alternator Output lug (Bat). Insulate and stow ENGINE SECTION wire #914 (wht). Do not install jumper wire. No wires are connected to Alternator terminals 1 & 2. If alternator output is greater than 65 amps refer to Figure 7-2B and the caution on page 6.
- 7.2.5 When using a 1-wire alternator you must use a voltmeter or ammeter. A WARNING LIGHT CANNOT BE WIRED IN.

CAUTION: IF USING AN ALTERNATOR WITH AN OUTPUT LARGER THAN 65 AMPS, YOU WILL ALSO NEED TO USE THE RED 10 GAUGE WIRE #960 AND THE RED 8 GAUGE WIRE INCLUDED IN THE BOX. THE WIRE END WITH THE RING TERMINAL AND RUBBER BOOT WILL CONNECT TO THE ALTERNATOR OUTPUT LUG WITH #915. ROUTE THE OTHER END TO THE MAXI FUSE TERMINAL WITH WIRE #916. CUT THE WIRE AND CRIMP ON A RING TERMINAL. NOW INSTALL A RING TERMINAL ON THE REMAINING RED 8 GAUGE WIRE AND ATTACH IT TO THE STARTER SIDE TERMINAL OF THE MAXI FUSE. CUT THE 8 GAUGE RED WIRE TO LENGTH, CRIMP ON A RING TERMINAL AND ATTACH IT TO THE MAIN SOLENOID LUG WITH THE POSITIVE BATTERY CABLE. SEE FIGURE 7-2A.

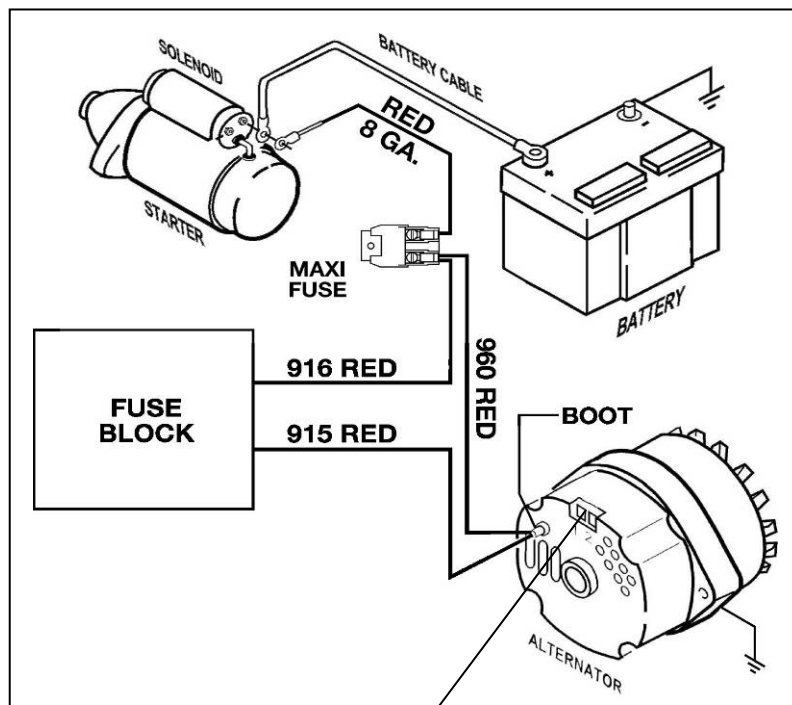

Figure 7-2A High Output Wire

* These terminals will not be used on One Wire alternators. They will normally have a black plastic plug which blocks off the terminals.
** If you do not have a One Wire alternator refer to Figure7-2.

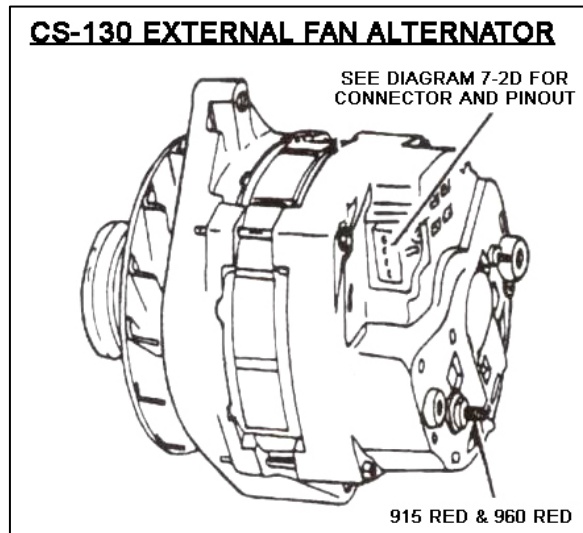

Figure 7-2B CS-130 External Fan Alternator

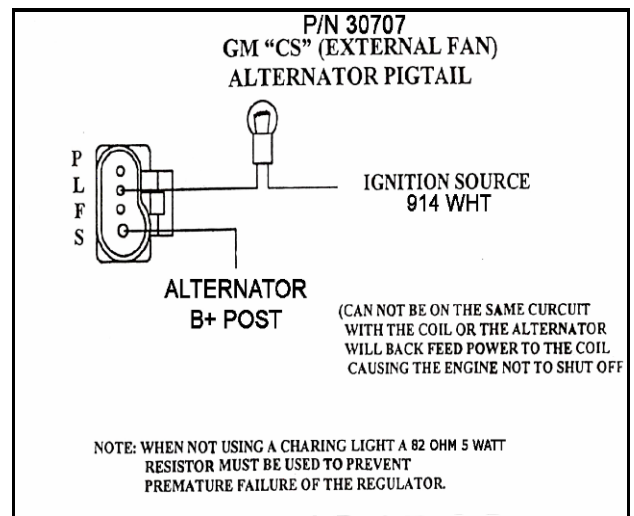

Figure 7-2C CS-130 Connector and Pin Out

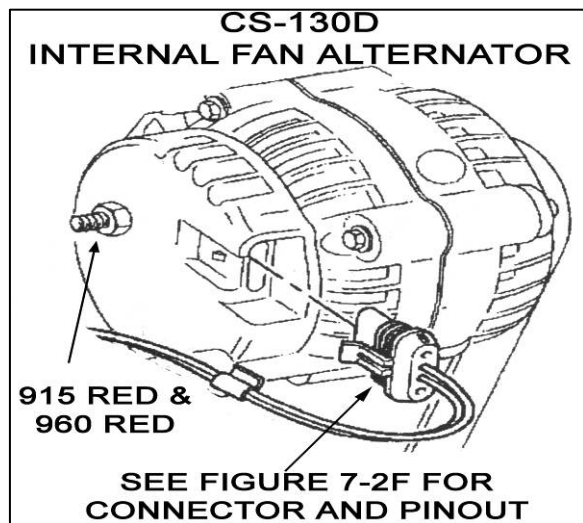

Figure 7-2D CS-130D Internal Fan Alternator

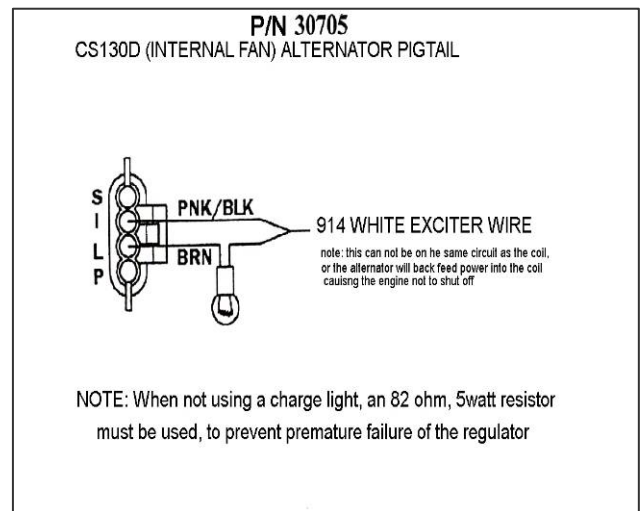

Figure 7-2E CS-130D Connector and Pin Out

7.3 GM Ignition (Start/Run) System. See Figure 7-4.

Note: If you are going to install an ammeter, see **Section 10.3** first.

7.3.1 With crimping tool, attach Maxi Fuse (**Figure 7-3**) onto end of ENGINE SECTION (single) 10 ga. wire #916 (red) AFTER having routed wire from the Fuse Panel to the Starter Solenoid. This serves as a fuse to protect the entire harness. DO NOT OMIT IT!

7.3.2 Connect wire #916 - with Maxi Fuse installed – to the Starter Solenoid Battery terminal. This is the same lug that the large red cable from the battery is normally connected to.

7.3.3 Connect ENGINE SECTION A wire #919 (pur) to the Starter Solenoid Start (S) terminal. (See illustration on page 31)

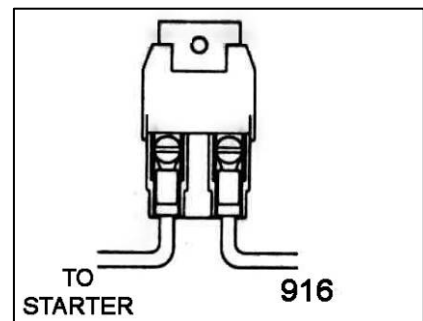

Figure 7-3 Maxi Fuse

- 7.3.4** If you are using the Ballast Resistor, mount it away from other wiring or hoses. The Ballast Resistor gets very hot during operation. Connect ENGINE SECTION A wire #920 (pnk) to one end of the Ballast Resistor. Connect the other end of the Ballast Resistor to the Ignition Coil B+ terminal with 14-gauge wire (you may have enough pink wire left over to accomplish this). If you are not using a Ballast Resistor, connect wire #920 directly to the Ignition Coil B+ terminal.

Note: The ballast resistor has been deleted from this kit due to lack of consumer usage. If one is needed in your application, please call Painless Performance at 800-423-9696 for assistance.

Important Note! For HEI systems route wire #920 (pnk) to the Distributor and attach it to the terminal labeled BAT. No Ballast Resistor is required.

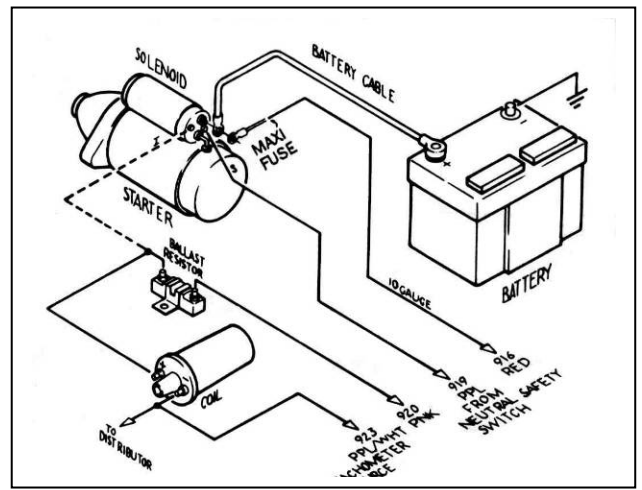

Figure 7-3A GM Ignition (Start-Run) System

- 7.3.5** The Ignition Coil NEGATIVE (-) terminal is connected to the Distributor. Also Connect ENGINE SECTION A wire #923 (pur/wht) to the Ignition Coil NEGATIVE (-) terminal. This is the tachometer source. If you are not using a tachometer, insulate and stow wire #923.
- 7.3.6** A 14-gauge wire connected from the Starter Solenoid Ignition (I) terminal to the ignition coil side of the Ballast Resistor is optional. This wire (the dashed line in **Figure 7-3A**) serves as a ballast resistor BYPASS during engine starting. However, if the starter solenoid shorts out, which is not unusual, the engine will stop running and will not restart as long as this wire is connected. You may therefore choose to omit it. If you are not using a Ballast Resistor, leave the Starter Solenoid Ignition (I) terminal unconnected and do not install the bypass wire.

8.0 HEADLIGHT SECTION A. See Figures 8-1

- 8.1.1** Connect HEADLIGHT SECTION A wire #924 (grn) to the Horn's hot terminal. TURN SIGNAL SECTION wire #953 (blk) was connected in the Turn Signal Connector section of these instructions. The Horn Relay is pre-wired into the Fuse Panel. **NOTE: The factory horn relay is NOT used in this harness.**
- 8.1.2** Connect HEADLIGHT SECTION A wires #908 (lt.grn) and #909 (tan) to the green and tan wires of BOTH Headlamp Connectors. Connect the black wires of the Headlamp Connectors to Chassis Ground. You should have enough wire to accomplish this. You have been supplied with two small grommets (**Figure 3-1**) should you need to pass these wires through a fender well. Don't forget to thread them onto the wires BEFORE you connect the wires.
- 8.1.3** Connect HEADLIGHT SECTION A wire #927 (brn) to ALL front Park Lights. Connect HEADLIGHT SECTION A wire #925 (blu) to the RIGHT FRONT Turn Signal. Connect wire #926 (lt.blu) to the LEFT FRONT Turn Signal. **Note: Don't confuse Park Lights with Turn Signals.**
- 8.1.4** If not using an electric cooling fan, the #901 is not used.

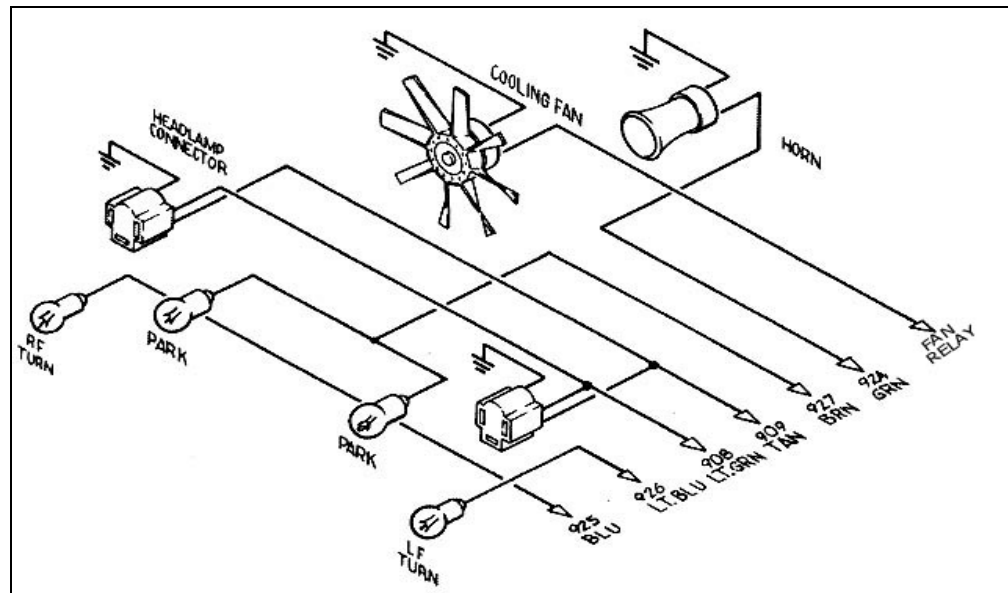

Figure 8.1 HEADLIGHT SECTION A Wiring

11.0 Steering Column Wiring - Turn Signal & Ignition Switch Connectors

11.1.1 There are two different plugs on most tilt columns. The difference is in the length of the male plug that is mounted ON THE COLUMN. One plug is 3-7/8" (3.875") long and the other is 4-1/4" (4.250"). This is only a difference of 3/8" (0.375"), so measure the plug carefully. The Wire Harness Kit has included two different female connectors to mate with the column-mounted plug. See **Figure 11-1** to determine which female connector is correct for your automobile.

You will need to cut the TURN SIGNAL SECTION wires to length and install the terminals provided. Choose the proper plug and install the terminals according to **Table 11-1**, as shown in **Figure 11-1**. The GM wire color codes have been included for reference. **Note:** *The terminals will only insert into the connector ONE WAY, as shown in Figure 11-1. Make certain you are inserting the wire into the CORRECT LOCATION as the terminals are difficult if not impossible to remove once inserted.*

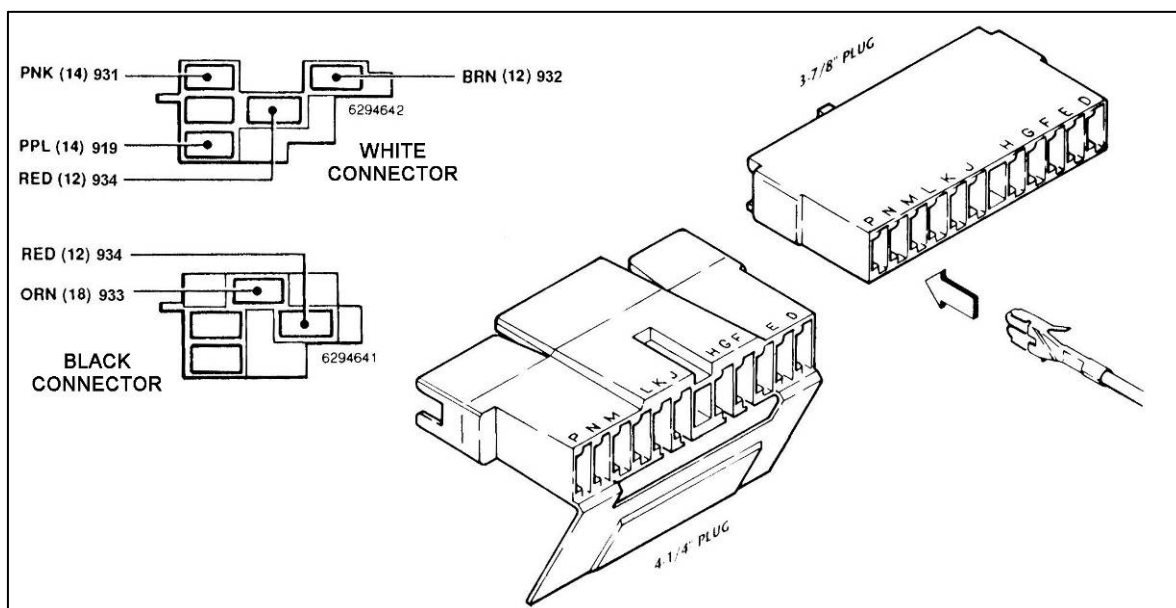

Figure 11-1 GM Turn Signal Connectors

- 11.1.2** The Steering Column Wiring comes with GM ignition switch connectors pre-wired. See **Table 11-1** and **Figure 11-1** for color codes, wire numbers, and wire designations for the Ignition Switch Connectors.
- 11.1.3** IGNITION SWITCH SECTION wire #980 (pur from ignition switch), and #919 (pur to starter solenoid) have had extra length added for use with a console shifter. Depending on your application, these wires will be either be routed to the floor mounted neutral safety switch, or to the column mounted neutral safety switch. In either case, these wires must be terminated and connected to the neutral safety switch. Failure to use/install a neutral safety switch can result in an unsafe operating condition. *Please, for safety's sake install a neutral safety switch !!*
- 11.1.4** The harness does not support seat belt buzzers or key alarms.
- 11.1.5** To supply power to a fuel injection system, use ENGINE SECTION A wire #920 (pnk) as the fused ignition power source.

TURN SIGNAL SECTION

GM Color	Designation	Painless Wire No.	Painless Color	Turn Signal Connector
Blk	Horn	953	Blk	G
Lt.Blu	LF Turn Signal	926	Lt.Blu	H
Dk.Blu	RF Turn Signal	925	Dk.Blu	J
Brn	Hazard Flasher	951	Brn	K
Pur	Turn Flasher	952	Pur	L
Ylw	LR Turn Signal	949	Ylw	M
Grn	RR Turn Signal	948	Grn	N
Wht	Stop Lamp Switch	918	Wht	P

IGNITION SWITCH SECTION

		Painless Wire No.	Painless Color
Pur/Wht	Ignition Start	919	Pur
Pnk	Ignition Coil	931	Pnk
Brn	Accessory Fuse Panel	932	Brn
Orn	Ignition Switched Fuse Panel	933	Orn
Red*	Battery B+	934	Red
Red*	Battery B+	934	Red

* See note 8 on page 28

Table 11-1 GM Ignition & Turn Signal Wiring

12.0 Connecting an Ammeter and the Maxi Fuse. See Figure 12-1, & 12-2

- 12.1.1** Most, but not all Ammeters must be inserted IN SERIES onto the ENGINE SECTION (single) 10-gauge wire #916 (red) that routes from the Fuse Panel to the Starter Solenoid on GM (**Section 7.3**).

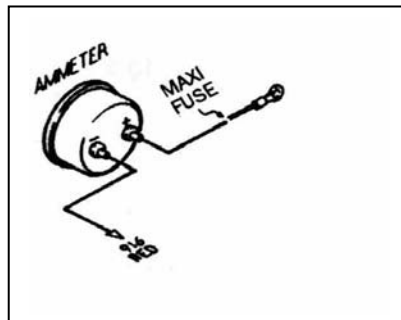

Figure 12-1 Ammeter & Maxi Fuse

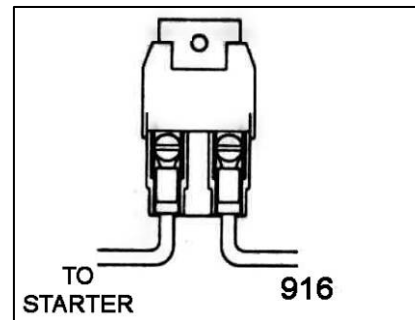

Figure 12-2 Maxi Fuse

- 12.2.2** The overall physical length of this circuit should be as short as possible (allow some slack, however). You may have to cut wire #916 and you may have to add some additional length of 10-gauge wire. USE ONLY 10-GAUGE WIRE OR LARGER.
- 12.2.3** Route wire #916 (from the Fuse Panel) and connect to the Ammeter NEGATIVE terminal. (**Figure 12-1**)
- 12.2.4** Route the remainder of wire #916 from the Ammeter POSITIVE terminal to the Maxi Fuse terminal. Connect the other side of the Maxi Fuse (**Figure 12-2**) to the Starter Solenoid Battery (B+) terminal.

CAUTION: BOTH AMMETER TERMINALS MUST ABSOLUTELY BE ISOLATED FROM GROUND. IF EITHER AMMETER TERMINAL COMES IN CONTACT WITH GROUND A HARNESS FIRE IS INEVITABLE. USE EXTREME CARE AND DILIGENCE IN CONNECTING AMMETERS.

CAUTION: BE SURE YOUR AMMETER'S CURRENT (AMPS) RATING EXCEEDS THE CURRENT OUTPUT OF YOUR ALTERNATOR. PERFECT PERFORMANCE PRODUCTS, LLC DOES NOT RECOMMEND USING ANY AMMETER RATED AT LESS THAN 45 AMPS. DO NOT USE AN AMMETER WITH ANY HIGH OUTPUT ALTERNATOR (MORE THAN 55 AMPS)

12.2 Instrument Panel Wiring

12.2.1 General Motors has, over the years, used many different configurations for the instrument cluster. Warning lights, gauges, etc. While our harness will accommodate most any configuration, as well as aftermarket gauges, it is all but impossible to include all of the diagrams/pinouts in this manual. We can offer general guidelines for this, but a factory schematic for your particular application is the best information.

12.2.1 Connect the wires of the INSTRUMENT PANEL SECTION as indicated in **Diagram 1** in the back of this manual. Cap & stow any unused wires.

12.2.2 Connect a jumper from the #935 (red/white) to all gauges' power or "I" terminals. Connect a jumper from the #930 (brn) wire to all gauges' illumination terminals. In some cases, you will have to connect a ground wire (16 ga) from the gauges to a good ground, such as one of the dash mounting brackets.

12.3 A/C and HEAT

12.3.1 This harness has provision for the heater/blower circuit on most GM intermediate vehicles. You will need to re-use the existing pigtailed for factory style connections into the fan switch, blower resistor, and high blower relay(if so equipped).

12.3.2 Connect the #904 (blk/wht) to the heater control unit. This is the power wire for the heater control head. Connect the #'s 981(orn), # 982 (orn), #983 (lt blu) and # #984 (ylw) as illustrated in figure **12-3**.

12.3.3 There were several A/C system configurations used in the 1969-1974 model years. Our harness will accommodate most of these units, using the above mentioned connections however, the existing pigtailed/connectors will be need to be used.
A Factory Diagram for your particular application is your best source of information on these connections.

12.3.4 If you are using an aftermarket A/C Heat system, the #904 (blk/wht) will be the 12v switched to the control unit, the #902 (blk/wht) is the signal wire to the compressor. Most aftermarket units require a separate power source for valves, relays etc. Consult the manual of the particular manufacturer for specific instructions on this connection.

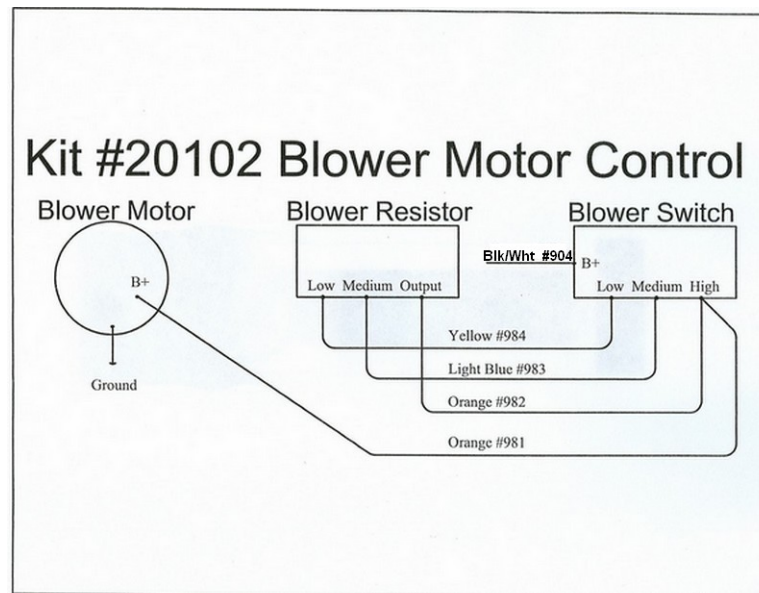

Figure 12-3 Heater/Blower Connection

13.0 HEADLIGHT SECTION B Wiring.

- 13.1.1 Connect the 6 wires of HEADLIGHT SECTION B, the Dome and Interior Light return circuit, and the Headlamp Switch Ground as shown. If you do not have a GM headlight switch, you should trace out the wires of your existing harness and connect the new harness according to **Table 17-2**.

Note: On late-style GM headlight switches, the park lights terminal to which wire #927 (brn) is connected (shown in **Figure 13-1**) has been omitted. In this case, wire #927 must be connected as indicated by the dashed line in **Figure 13-1**.

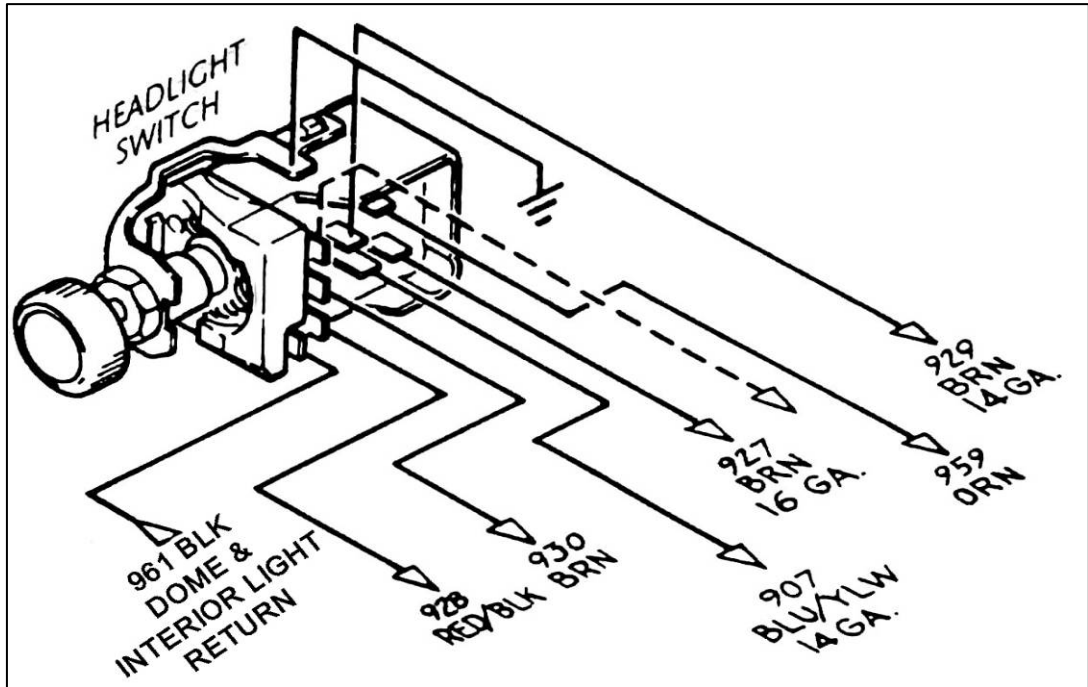

Figure 13-1 HEADLIGHT SECTION B Wiring (Painless Part #80152)

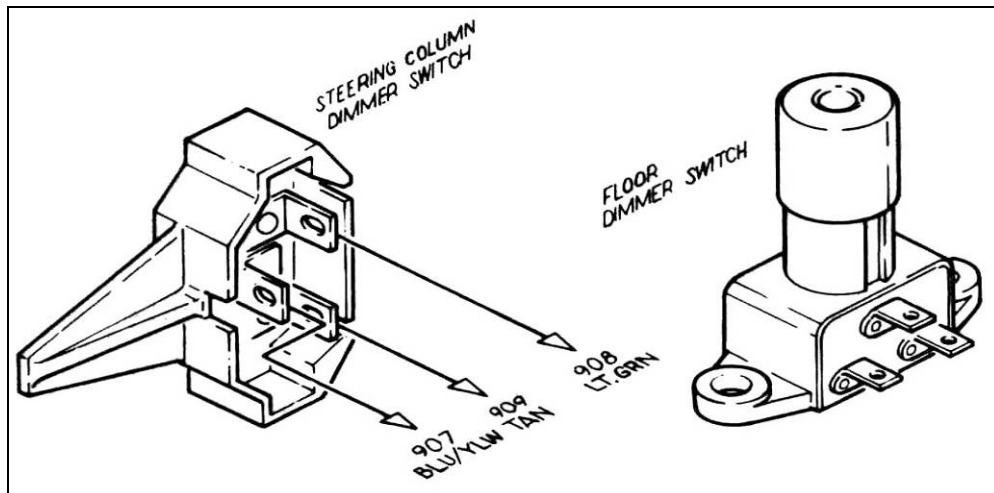

Figure 13-2 Dimmer Switches (Push Button Style – Painless Part #80150)

14.0 Interior Lighting.

- 14.1 Interior Lights are switched through the door switches and the dash-mounted headlight switch, which is usually rotated counter-clockwise to turn on. The dome light return (#961blk), exits the Harness near the fuse panel, and must be connected to the door pin switches to operate. These switches apply ground to the circuit. YOU WILL NEED TO SUPPLY THESE GROUND WIRES. 12V is continually present at the light bulbs. See **Figure 14.1**
- 14.2 If possible leave your existing interior light wiring intact. The Painless harness supplies the 12V feed (B+) to the circuit via TAIL SECTION wire #945 (wht) and a ground via TAIL SECTION wire #961 (blk).

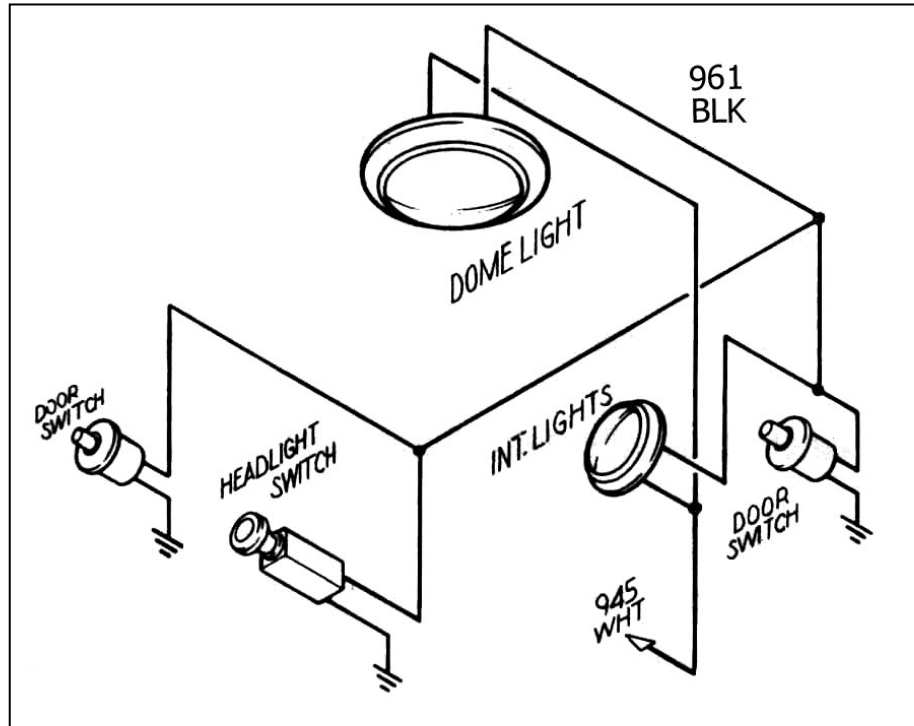

Figure 14.1 Interior Lighting (GM Style Jamb Switch – Painless Part #80170)

15.0 Brake Light Switch

- 15.1.1 Connect wires #917 (orn) and #918 (wht) to the Brake Light Switch. These wires are bundled with the ignition switch section
- 15.1.2 The Third Brake Light wire is pre-connected at the Switch end. Connect TAIL SECTION wire #950 (orn) to the Third Brake Light if applicable. If not using a 3rd brake light, insulate and stow this Wire.

16.0 Tail Section Wiring

- 16.1.1 Connect the wires of the TAIL and TURN SIGNAL SECTIONS as indicated in **Table 11-2** with the exception of #918 (wht), #948 (grn), #949 (ylw) and #950 (orn).
- 16.1.2 These 4 wires will be connected according to one of the diagrams shown in **BELOW**. Which diagram you will use depends on whether or not you have one bulb on each side of the vehicle that is for the brake/tail **and** Turn Signal Lights (this is referred to as integrated lights) **or** you have **more than one** bulb on each side **and** the Brake and Turn Signal Lights are hooked to different bulbs (referred to as separate Brake/Turn Lights).

Note A: *If you have Integrated Brake Lights you must use bulbs that have two (2) filaments in them such as in an 1157 bulb.*

Note B: *The three wires shown in these diagrams are connected to the "brighter" of the two filaments when using a two-filament bulb (the Tail Lights are usually connected to the "Dimmer" filament). The Tail Lights, License Plate Lights, Reverse Lights, etc. are not shown on the diagrams for clarity.*

Note C: *In the separate Brake Light diagram the arrangement shown is only one of several ways to wire a vehicle. The important thing is that the Brake and Turn Signal Lights use completely separate bulbs.*

Note D : *When you have Integrated Brake Lights on your vehicle the Turn Signal switch acts as a brain to control when the Lights in the rear are on constantly (braking) or flashing (turning) or a combination of both. The Turn Signal switch you use must be built to do this! If you are using a steering column of unknown origin, that was originally in a vehicle that had separate Brake Lights then the switch will not work for Integrated Brake Lights. See Figure 16-1 & 16-2.*

Note E: *Almost all light bulbs get the ground they need through the socket housing. If you mount your socket housing into anything other than a grounded metal part then you will need to provide a separate ground wire.*

Note F: *If you are using Halogen brake/tail light bulbs a relay kit (Painless 30105) MUST be used to prevent damage to your turn signal & brake light switch*

INTEGRATED BRAKE LIGHTS

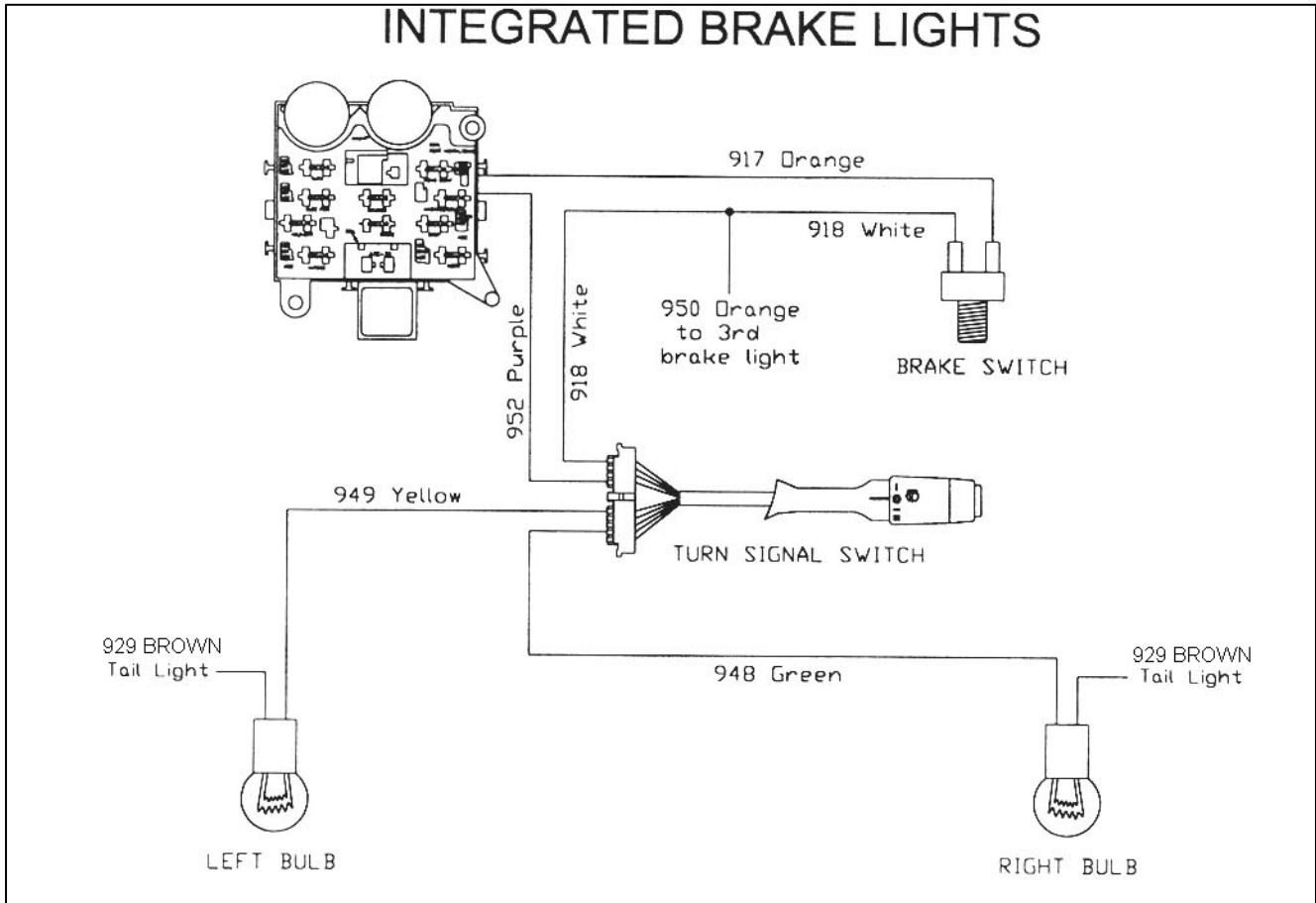

Figure 16-1 Integrated Brake Lights

SEPARATE TURN/ BRAKE LIGHTS

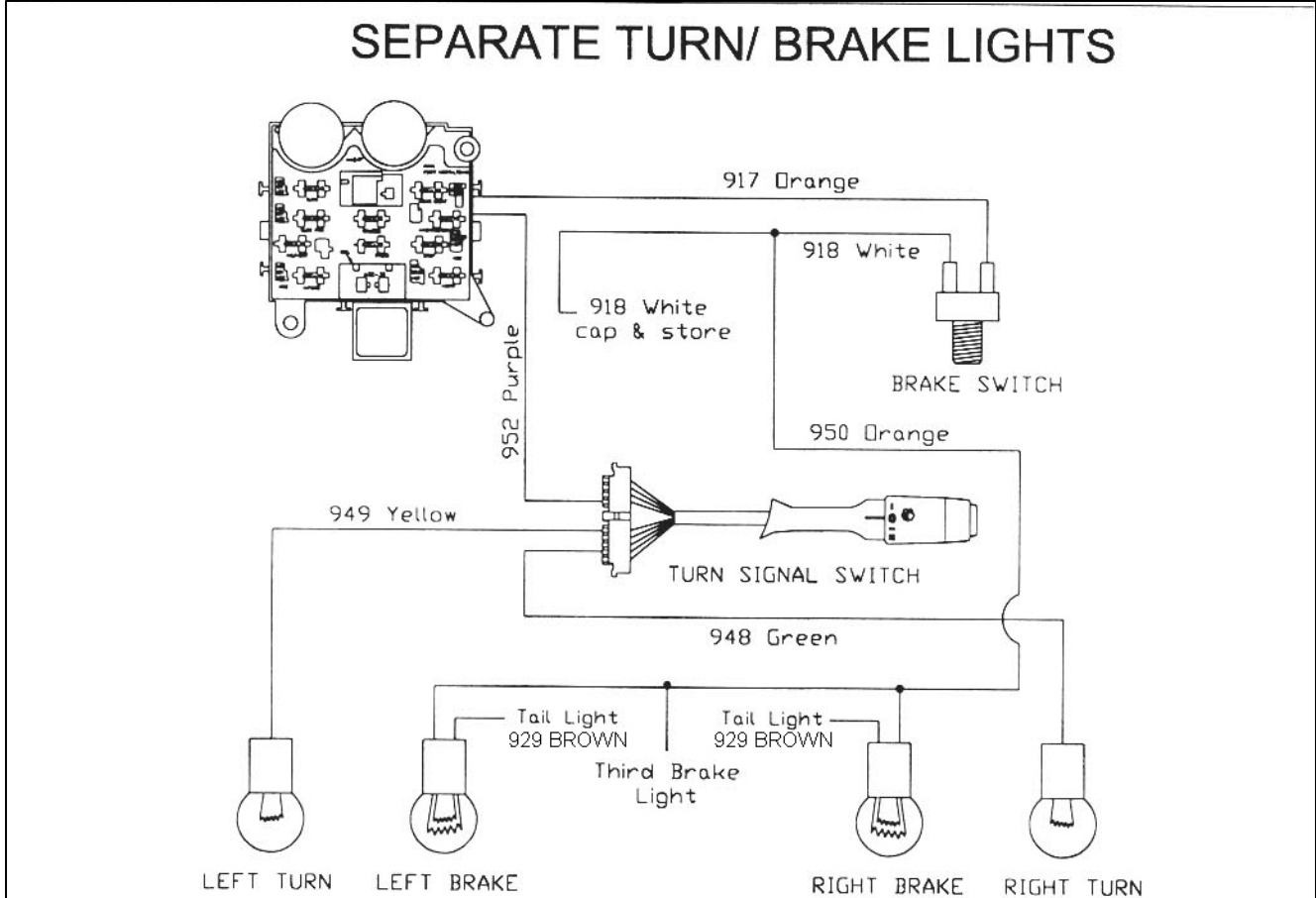

Figure 16-2 Separate Turn/Brake Lights

17.0 WIRE CONNECTION INDEX AND FUSE REQUIREMENTS

17.1 Wire Connection Index

In each section, connect the wire, as identified by its wire color, to the appropriate item in the CONNECT TO column. Pay close attention to the **Notes** in this section, as identified by a small, raised number such as the one at the end of this sentence. ❶

Table 17-2 is divided into sections that correspond to the sections of your wire harness. (ACCESSORY SECTION B+, DIMMER SWITCH SECTION, etc.). The index is divided vertically into six columns. COLOR, GAUGE, NUMBER, CONNECT TO, ORIGIN, and SECTION OF ORIGIN.

The columns labeled ORIGIN and SECTION OF ORIGIN are for your reference ONLY. The items in these columns tell you where each wire originates (ORIGIN) and from which section (SECTION OF ORIGIN) of the harness.

The column labeled NO. contains a 900-series number that is used to identify various wires in the wiring diagrams that are a part of these instructions.

Many (but not all) of the wire numbers occur TWICE in this index. That is because you will be connecting BOTH ENDS of many of the particular wire segments. However, some wire segments are pre-connected at one end. For instance, all wires originating from the fuse panel and certain other wires such as those originating from the fuse panel and certain other wires such as those originating from the horn relay, the dimmer switch, and the instrument panel section. **These pre-connected wires are identified by an asterisk (*) in the ORIGIN column.**

17.2 Fuse Requirements

Cigarette Lighter.....	20
Headlight Switch.....	30
Emergency Flashers.....	15
Turn Signals.....	15
Gauges.....	10
AC/Heat Relay.....	5
Radio (Constant).....	10
Horn.....	20
Door Lock.....	20
Wipers.....	15
Brake Switch.....	20
Dome/Trunk.....	10
Electric Fan Relay.....	5
Power Antenna.....	10
Power Windows.....	20
Electric Fuel Pump.....	15
Coil.....	30
Radio Ignition (Switched).....	10
Backup/Cruise Control.....	10

Table 17-1 Fuse Requirements

Color	Ga.	No.	Connect to	Wire Starting Point	Section of Starting Point
ACCESSORY SECTION SWITCHES					
Gry/Wht	18	901	Cooling Fan Switch	Fan Relay	Headlight Section A
Blk/Wht	14	902	AC/Heat Switch	A/C Compressor	Engine Section A
ACCESSORY SECTION B+					
Tan	14	903	Cigarette Lighter B+	Fuse Panel*	Fuse Panel
Blk/Wht	14	904	AC/Heat Switch B+	Fuse Panel*	Fuse Panel
Blu	16	905	Wiper Switch B+	Fuse Panel*	Fuse Panel
Gry/Wht	18	906	Cooling Fan Switch B+	Fuse Panel*	Fuse Panel
DIMMER SWITCH SECTION					
Blu/Ylw ²	14	907	Dimmer Switch	Headlight Switch	Headlight Section B
Lt.Grn	14	908	Dimmer Switch	High Beam	Headlight Section A
Tan	14	909	Dimmer Switch	Low Beam	Headlight Section A
DOOR SECTION A					
Ylw/Blk	14	910	Right Door Lock B+	Fuse Panel*	Fuse Panel
Ylw	14	911	Right Power Window B+	Fuse Panel*	Fuse Panel
DOOR SECTION B					
Ylw/Blk	14	912	Left Door Lock B+	Fuse Panel*	Fuse Panel
Ylw	14	913	Left Power Window B+	Fuse Panel*	Fuse Panel
ENGINE SECTION					
Wht	14	914	Alternator Exciter	Fuse Panel*	Fuse Panel
Red	10	915	Alternator B+	Fuse Panel*	Fuse Panel
Blk/Wht	14	902	A/C Compressor	A/C Central Switch	Accy. Section Switches
ENGINE SECTION (SINGLE WIRE)					
Red ³	10	916	Battery Positive or Starter Solenoid (Large Terminal)	Fuse Panel*	Fuse Panel
ENGINE SECTION A					
Orn ⁴	14	917	Brake Switch B+	Fuse Panel*	Fuse Panel
Wht	16	918	Brake Switch	Turn Signal Switch	Turn Signal Section
Pur ¹¹	12	919	Start Solenoid ("S" Terminal)	Neutral Safety Switch	Ignition Switch Section
Pnk	14	920	Coil B+	Fuse Panel*	Fuse Panel
Lt.Grn	18	921	Temperature Sending Unit	Temperature Gauge	Instrument Panel Section
Lt.Blu/Blk	18	922	Oil Pressure Sending Unit	Oil Pressure Gauge	Instrument Panel Section
Pur/Wht	18	923	Tachometer Source	Tachometer	Instrument Panel Section
Red	18	954	Electric Choke	Fuse Panel*	Fuse Panel
HEADLIGHT SECTION A					
Grn	14	924	Horn B+	Horn Relay*	Fuse Panel
Blu	18	925	Right Front Turn Signal	Turn Signal Switch	Turn Signal Section
Lt.Blu	18	926	Left Front Turn Signal	Turn Signal Switch	Turn Signal Section
Brn	18	927	Park Lights	Headlight Switch	Headlight Switch Section
Lt.Grn	16	908	High Beam	Dimmer Switch	Dimmer Switch Section
Tan	16	909	Low Beam	Dimmer Switch	Dimmer Switch Section
Gry/Wht	18	901	Fan Relay	Fan Switch	Accessory Section Switches

Table 17-2 Wire Connection Index, 1 of 3

Color	Ga.	No.	Connect to	Wire Starting Point	Section of Starting Point
HEADLIGHT SECTION B					
Red/Blk ⁹	12	928	Headlight Switch B+	Fuse Panel*	Fuse Panel
Blu/Ylw	14	907	Headlight Switch	Dimmer Switch	Dimmer Switch Section
Brn	14	929	Headlight Switch	Tail Lights	Tail Section
Brn	18	927	Headlight Switch	Park Lights	Headlight Section A
Brn ⁷	18	930	Headlight Switch	Instr. Panel Lighting	Instrument Panel Section
Orn ¹⁰	14	959	Headlight Switch B+	Fuse Panel*	Fuse Panel
IGNITION SWITCH SECTION					
Pnk	14	931	Ignition Switch (Coil Ignition)	Fuse Panel*	Fuse Panel
Brn	12	932	Ignition Switch Accessory	Fuse Panel*	Fuse Panel
Orn	12	933	Ignition Switch Ignition	Fuse Panel*	Fuse Panel
Red ⁸	12	934	Ignition Switch B+	Fuse Panel*	Fuse Panel
Pur ⁵	12	980	Ignition Switch Start	Neutral Safety Switch	Engine Section A
INSTRUMENT PANEL SECTION					
Red/Wht	18	935	Voltmeter Source & Gauges B+	Fuse Panel*	Fuse Panel
Grn	18	936	High Beam Indicator	Dimmer Switch*	Dimmer Switch Section
Lt.Blu	18	937	Left Turn Indicator	Left Front Turn Signal*	Turn Signal Section
Blu	18	938	Right Turn Indicator	Right Front Turn Sig.*	Turn Signal Section
Brn	18	930	Instrument Panel Lighting	Headlight Switch	Headlight Section B
Pnk	18	939	Fuel Gauge	Fuel Sending Unit	Tail Section
Lt. Grn	18	921	Temperature Gauge	Temp. Sending Unit	Engine Section A
Lt.Blu/Blk	18	922	Oil Pressure Gauge	Oil Pres. Sending Unit	Engine Section A
Pur/Wht	18	923	Tachometer	Tachometer Source	Engine Section A
Orn/Blk	18	955	Accessory Power (Switched)	Fuse Panel*	Fuse Panel
RADIO SECTION					
Red	18	940	Radio B+ Unswitched (Constant)	Fuse Panel*	Fuse Panel
Red/Blk	18	941	Radio B+ Switched	Fuse Panel*	Fuse Panel
Pur/Blk	18	942	Radio: Power Antenna	Power Antenna	Tail Section
Clear ⁶	20	943	Radio Right Rear Speaker Out	Right Rear Speaker	Speaker Section
Clear ⁶	20	944	Radio Left Rear Speaker Out	Left Rear Speaker	Speaker Section
SPEAKER SECTION					
Clear ⁶	20	943	Right Rear Speaker	Radio R. Rear Spkr.Out	Radio Section
Clear ⁶	20	944	Left Rear Speaker	Radio L. Rear Spkr.Out	Radio Section
TAIL SECTION					
Wht	18	945	Dome Lights B+	Fuse Panel*	Fuse Panel
Grn/Blk	16	946	Trunk Accessory Light B+	Fuse Panel*	Fuse Panel
Ylw/Wht	14	947	Electric Fuel Pump B+	Fuse Panel*	Fuse Panel
Grn	14	948	Right Rear Turn Signal	Turn Signal Switch	Turn Signal Section
Ylw	14	949	Left Rear Turn Signal	Turn Signal Switch	Turn Signal Section
Pnk	18	939	Fuel Sending Unit	Fuel Gauge	Instrument Panel Section
Brn	14	929	Tail Lights	Headlight Switch	Headlight Section B
Pur/Blk	18	942	Power Antenna	Radio: Power Antenna	Radio Section
Orn	18	950	Third Brake Light	Turn Signal Switch*	Turn Signal Section
Lt.Grn	18	956	Backup Lights	Backup Switch	Cruise Control Section
Blk	18	961	Dome Light Ground	Interior Light Harness	Near Fuse Panel

Table 17-2 Wire Connection Index, 2 of 3

TURN SIGNAL SECTION					
Brn	14	951	Emergency Flasher Switch B+	Emer. Flasher Relay*	Fuse Panel
Pur	14	952	Turn Signal Switch Flasher B+	Turn Flasher Relay*	Fuse Panel
Blk	18	953	Horn Switch	Horn Relay*	Fuse Panel
Grn	14	948	Turn Signal Switch	Right Rear Turn Signal	Tail Section
Ylw	14	949	Turn Signal Switch	Left Rear Turn Signal	Tail Section
Blu	18	925	Turn Signal Switch	Right Front Turn Signal	Headlight Section A
Wht	16	918	Turn Signal Switch	Brake Switch	Engine Section A
Lt.Blu	18	926	Turn Signal Switch	Left Front Turn Signal	Headlight Section A
CRUISE CONTROL SECTION					
Pnk	18	957	Cruise Control Switch	Fuse Panel*	Fuse Panel
Lt.Grn	18	958	Backup Switch	Fuse Panel*	Fuse Panel
Lt.Grn	18	956	Backup Switch	Backup Lights	Tail Section

Table 17-2 Wire Connection Index, 3 of 3

NOTES:

1. 2-color wires: 2nd color (stripe) may not be intense color. Observe two-color wires closely.
2. This section consists of only one large (10 gauge) wire.
3. From fuse panel to brake switch.
4. This wire is cut and extended so that your existing neutral safety switch circuit can be wired into the harness. The neutral safety switch is located at the base of the steering column. Do not attempt to defeat your automobile's neutral safety switch. If your automobile does not have a neutral safety switch, please install one.
5. These are two (2) wires, bonded together. One wire is Speaker POSITIVE (+) and the other wire is Speaker NEGATIVE (-).
6. This wire needs to go from the headlight switch to the instrument panel lights.
7. There are two (2) Red 934 wires that MUST both be connected to the "Batt" terminal of the ignition switch. These wires supply all of the ignition switched power that goes to the fuse panel and both are needed because of the amount of power required to power all of the accessories.
8. This wire is power for the portion of the headlight switch that goes out to the headlights and front parking lights.
9. This wire is power for the portion of the headlight switch that goes out to the instrument panel lights and the tail lights. **NOTE: This wire is only used if your headlight switch has two power input terminals.**
10. This harness has 48" of extra length to accommodate a floor shifter. If a floor shifter is being used, utilize this extra length to route the 980 Purple to the neutral safety switch on the shifter or transmission and then to the starter solenoid. If not using a floor shifter, cut 980 Purple to length needed for the neutral safety switch and discard extra length.

INSTRUMENT PANEL SECTION WIRING

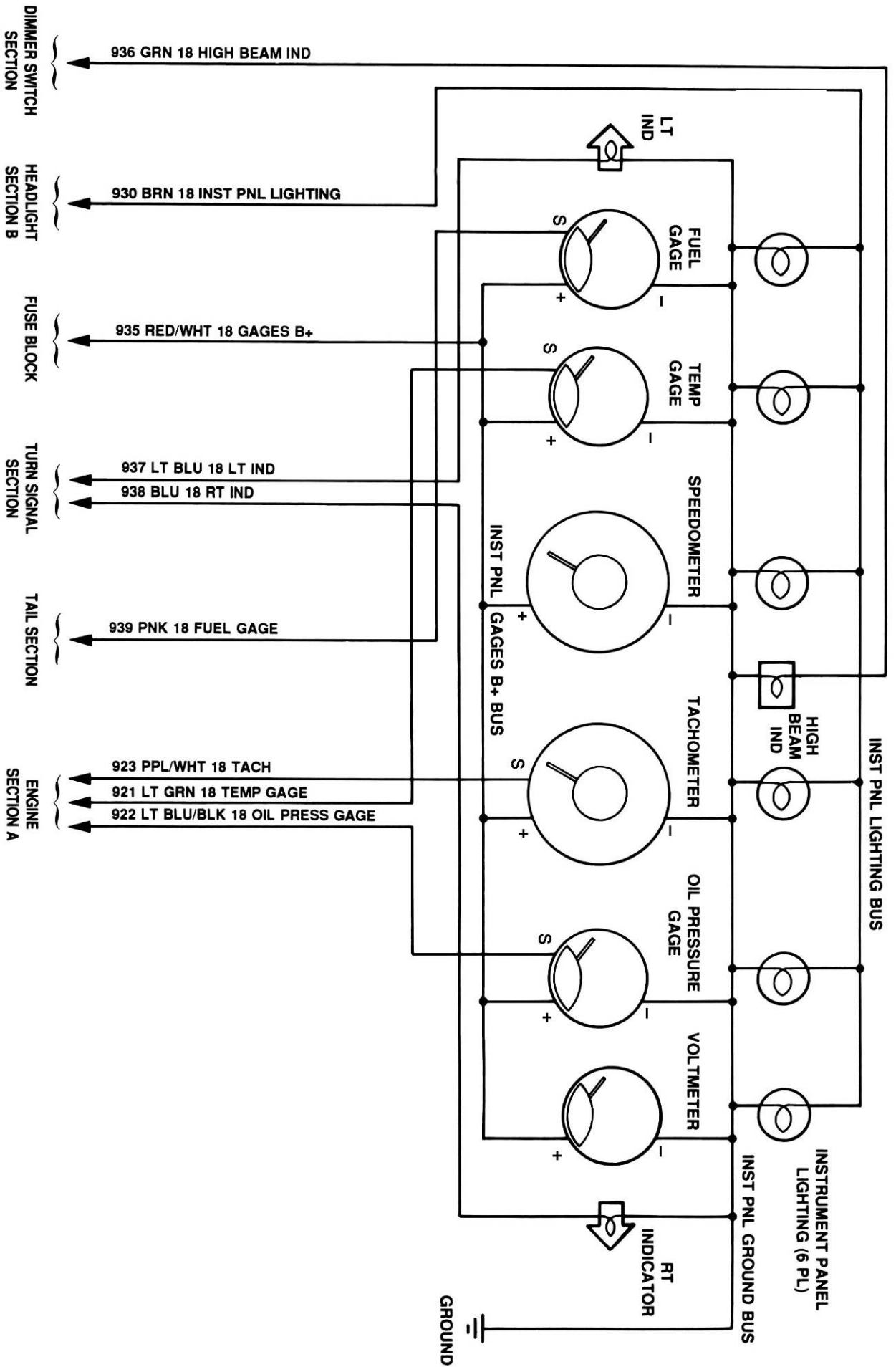

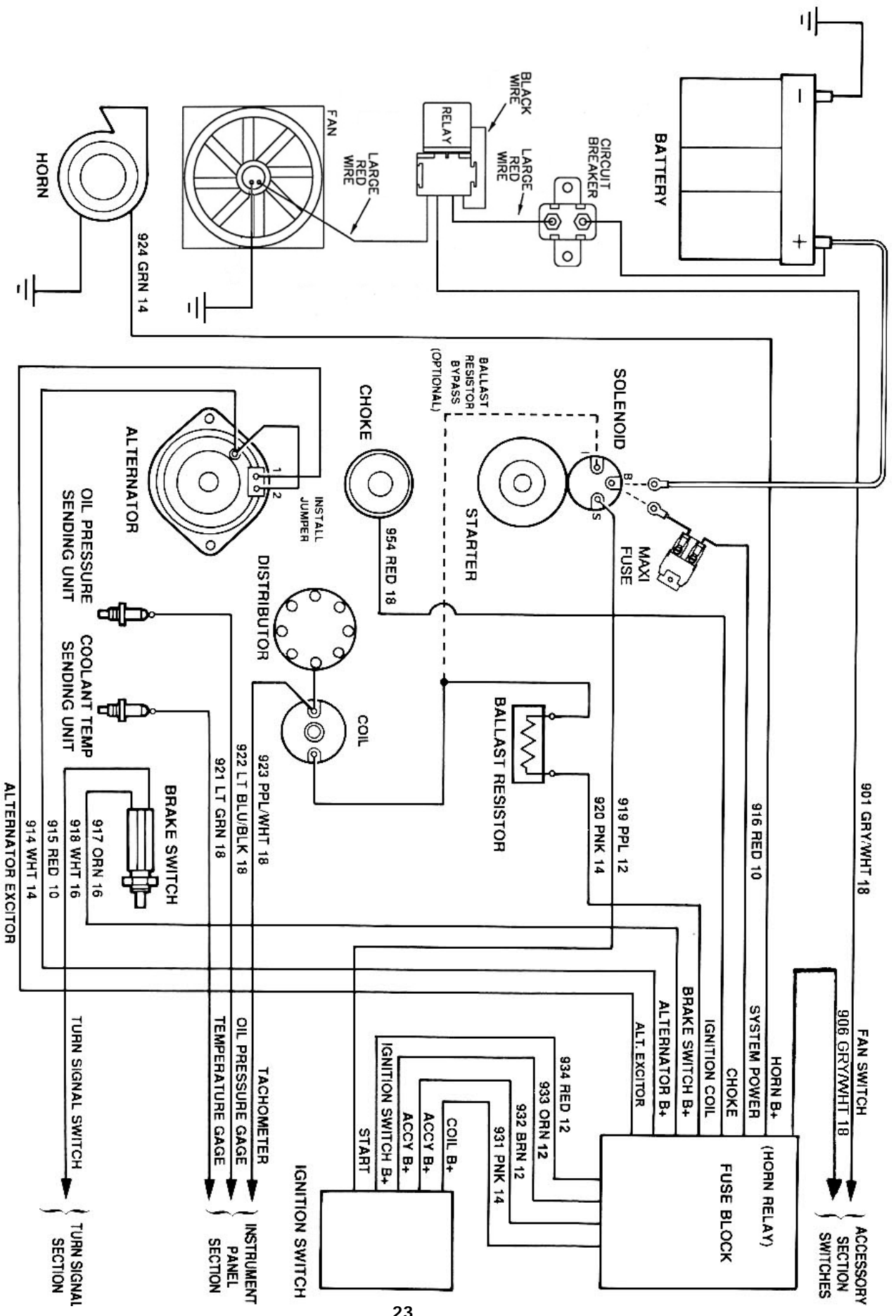

ENGINE WIRING

NOTE: The template drawing on this page may not be to scale, double check your measurements with the dimensions on the drawing before cutting the opening.

FIREWALL OPENING TEMPLATE

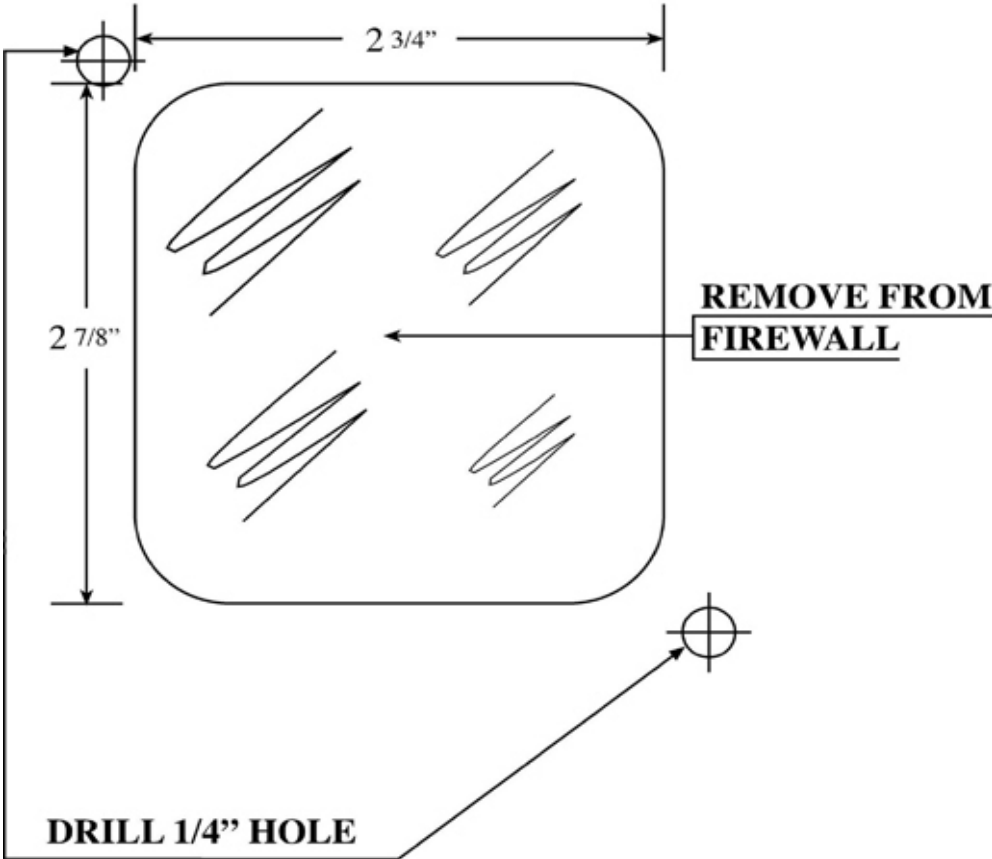

Painless Performance Limited Warranty and Return Policy

Chassis harnesses, fuel injection harnesses and Striker ColdShot units are covered under a lifetime warranty.

All other products manufactured and/or sold by Painless Performance are warranted to the original purchaser to be free from defects in material and workmanship under normal use. Painless Performance will repair or replace defective products without charge during the first 12 months from the purchase date. No products will be considered for warranty without a copy of the purchase receipt showing the sellers name, address and date of purchase. You must return the product to the dealer you purchased it from to initiate warranty procedures.