



Wire Harness Installation Instructions

FOR INSTALLING:

PART #10308

8-CIRCUIT MODULAR T-BUCKET HARNESS

Manual #90527



**Painless Performance Products Division
Perfect Performance Products, LLC
2501 Ludelle Street, Fort Worth, Texas 76105-1036
Phone (800) 423-9696**

Perfect Performance Products, LLC shall in no event be liable in contract or tort (including negligence) for special, indirect, incidental, or consequential damages, such as but not limited to, loss of property damage, or any other damages, costs or expenses which might be claimed as the result of the use or failure of the goods sold hereby, except only the cost of repair or replacement.

P/N 90527 Painless Wiring Manual

3rd Edition , May 13, 2005

Copyright © 2004 by Perfect Performance Products, LLC

TABLE OF CONTENTS

List of Figures.....	ii
List of Tables.....	ii
List of Diagrams.....	ii
1.0 Introduction.....	1
2.0 About These Instructions.....	1
3.0 Contents Of The Painless Wire Harness Kit.....	2
4.0 Tools Needed.....	2
5.0 Pre-Installation and General Harness Routing Guidelines.....	2
6.0 Harness General Installation Instructions.....	4
6.1 Rough Installation.....	4
6.2 Harness Attachment.....	4
6.3 Grounding The Automobile.....	5
6.4 Terminal Installation and Making Connections.....	5
6.5 Testing The System.....	5
7.0 GM - Specific Circuit Connections.....	6
7.1 Early GM Alternator - External Regulator.....	6
7.2 Late GM Alternator - Internal Regulator.....	6
7.3 GM One-Wire Alternator.....	7
7.4 GM Ignition System.....	8
7.5 Steering Column Wiring - Turn Signal & Ignition Switch Connections...	9
8.0 Ford - Specific Circuit Connections.....	10
8.1 Ford Alternator.....	10
8.2 Ford Ignition System.....	10
8.3 Steering Column Wiring - Turn Signal Connections.....	12
8.4 Steering Column Wiring - Ignition Switch Connections.....	12
9.0 Mopar - Specific Circuit Connections.....	15
9.1 Mopar Alternator.....	15
9.2 Mopar Ignition System.....	15
9.3 Steering Column Wiring - Turn Signal Connections.....	17
9.4 Steering Column Wiring - Ignition Switch Connections.....	17
10.0 All Makes - Specific Circuit Connections.....	19
10.1 Generator Charging System.....	19
10.2 Generator to Alternator Conversion.....	19
10.3 Connecting to Ammeter and the Maxi-Fuse.....	20
10.4 Headlight Section "A".....	20
10.5 Headlight Section "B".....	22
10.6 Instrument Panel Wiring.....	23
10.7 Brake Light Switch.....	23
10.8 Tail Section Wiring.....	23
10.9 Helpful Hints for Tail Section Wiring.....	25
11.0 Wire Connection Index and Fuse Requirements.....	25

LIST OF FIGURES

Figure 3.1	The Painless Wire Harness Kit.....	2
Figure 7.1	Early GM Alternator - External Regulator.....	6
Figure 7.2A	Late GM Alternator - Internal Regulator.....	7
Figure 7.2B	High Output Wire.....	7
Figure 7.3	Maxi-Fuse.....	8
Figure 7.4	GM Ignition System.....	8
Figure 7.5	GM Turn Signal Connectors.....	9
Figure 8.1A	Ford Alternator.....	11
Figure 8.1B	High Output Wire.....	11
Figure 8.2	Ford Ignition System.....	12
Figure 8.3	Ford Ignition Switch Connectors.....	14
Figure 8.4	Ford Ignition Diagram.....	14
Figure 9.1A	Mopar Alternator.....	15
Figure 9.1B	High Output Wire.....	16
Figure 9.2	Mopar Ignition System.....	17
Figure 10.1	Generator Charging System.....	19
Figure 10.2	Ammeter and Maxi-Fuse.....	19
Figure 10.3	Headlight Section "A" Wiring.....	21
Figure 10.4	Typical Fan Relay Installation.....	21
Figure 10.5	Dimmer Switches.....	22
Figure 10.6A	GM Style Headlight Switch.....	22
Figure 10.6B	Headlight Switch with High/Low Control.....	23
Figure 10.7	Integrated Brake Light and Separate Turn/Brake Lights.....	24
Figure 11.1	Fuse Requirements.....	25

LIST OF TABLES

Table 7.1	GM Ignition and Turn Signal Wiring.....	10
Table 8.1	Ford Ignition and Turn Signal Wiring.....	13
Table 9.1	Mopar Ignition and Turn Signal Wiring (1 of 2).....	18
Table 9.1	Mopar Ignition and Turn Signal Wiring (2 of 2).....	18
Table 11-1	Wire Connection Index (1 of 2).....	26
Table 11-1	Wire Connection Index (2 of 2).....	27

LIST OF DIAGRAMS

Diagram 1	Instrument Panel Section Wiring.....	28
Diagram 2	Engine Wiring.....	29

1.0 INTRODUCTION

You have purchased what we at Painless Performance Products believe to be the most up-to-date and easiest-to-install automotive wire harness on the market. It is designed for easy installation, even if you have no electrical experience.

The proper fuses have been pre-installed in the fuse block. In addition, all wires are color-coded. This will help you identify the different circuits during installation and later on if additions to the overall system are necessary. For fuse specifications and wire color designations, see **Section 11.0**.

The Painless wire harness is designed to be used in vehicles with a General Motors - keyed steering column, or other steering columns. All wire is 600 volt, 125°C, TXL. Standard automotive wire is GPT, 300 volt, 80°C, with PVC insulation.

This complete automobile wiring system has been designed with three major groups incorporated into it:

ENGINE/HEADLIGHT GROUP

Includes high beam, low beam, park, right turn, left turn, electric fan, horn, starter solenoid and battery feed, alternator and alternator exciter wire, coil, water temperature, and oil pressure.

DASH GROUP

Includes wires to connect gauges, indicator lights, and switches to their proper sources.

REAR LIGHT GROUP

Includes tail lights, left and right turn signals, brake lights, and fuel sender.

Installation requires four (4) easy steps:

1. Mount the fuse block
2. Route the wires
3. Cut off the excess wire
4. Terminate the wires

2.0 ABOUT THESE INSTRUCTIONS

The contents of these instructions are divided into major **Sections**, as follows:

1.0	Introduction
2.0	About These Instructions
3.0	Contents of Painless Wire Harness Kit
4.0	Tools Needed
5.0	Pre-Installation and General Harness Routing Guidelines
6.0	General Harness Installation Instructions
7.0	GM - Specific Circuit Connection Details
8.0	Ford - Specific Circuit Connection Details
9.0	Mopar - Specific Circuit Connection Details
10.0	All Makes - Specific Circuit Connection Details
11.0	Wire Connection Index and Fuse Requirements

Sections are divided into subsections and **Paragraphs**. Throughout these instructions, the **Figure** numbers refer to illustrations and the **Table** numbers refer to information in table form. These are located in Sections or Paragraphs corresponding to the number. Always pay special and careful attention to any *Notes*, especially those in the Tables, and any text marked **Caution**.

3.0 CONTENTS OF THE PAINLESS WIRE HARNESS KIT

Refer to **Figure 3-1** to take inventory. Please check to see you have everything you're supposed to in this kit. If anything is missing, contact the dealer where you purchased the kit or Painless Performance at (800) 423-9696. This Painless Wire Harness Kit contains the following items:

- A** The Main Wire Harness, with the Fuse Block wired in and fuses installed.
- B** 6 Groups of Rolled-Up Wire
- C** Headlamp Connector Cables.
- D** Maxi Fuse
- E** Firewall Grommet (large)
- F** 2 Fender Well Grommets (for Headlamps)
- G** 2 packages of Nylon Tie Wraps
- H** 2 GM Turn Signal Connectors
- I** 2 GM Ignition Switch Connectors
- J** Parts Box, containing a GM Alternator Connector, Terminals, Splices, Mounting Hardware, etc. This booklet, P/N 90533 Painless Wiring Manual.

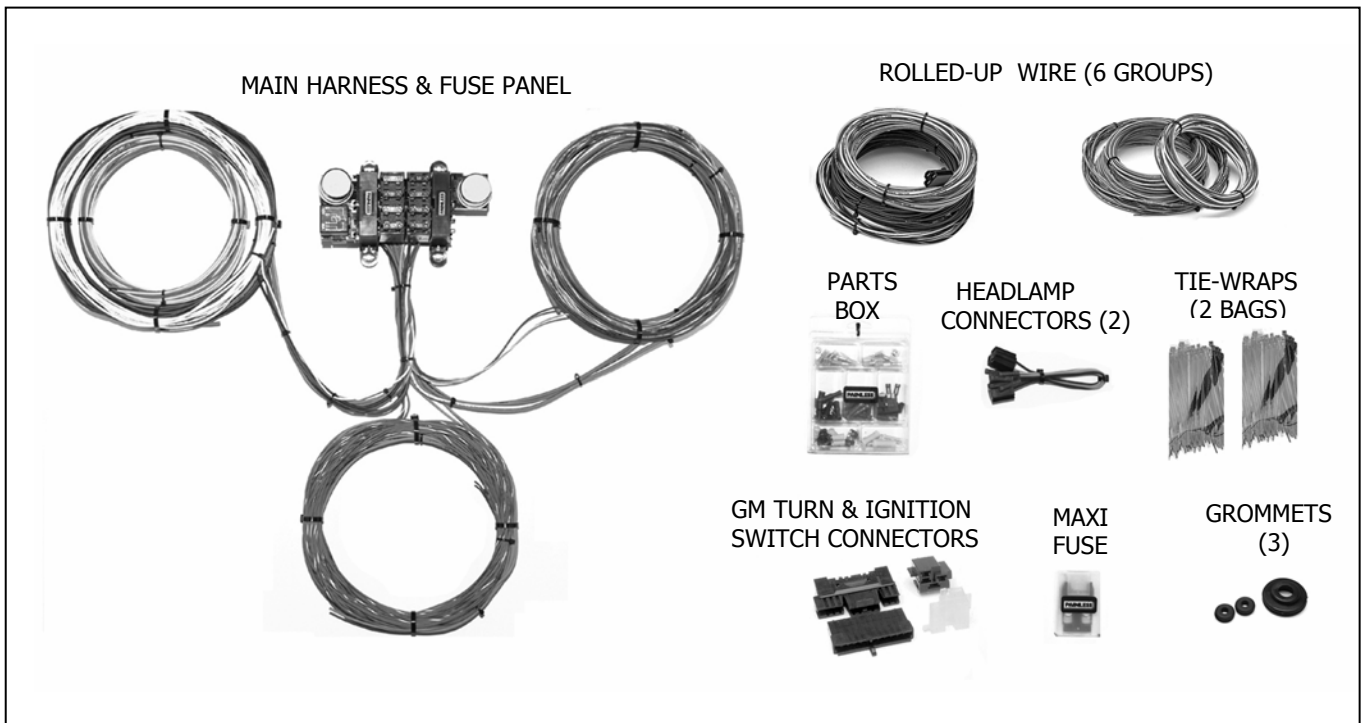

Figure 3-1 Painless Wire Harness Kit P/N 10308

4.0 TOOLS NEEDED

In addition to your regular tools, you will need, at least, the following tools:

- Crimping Tool *Note: Use a quality tool to avoid over-crimping.*
- Wire Stripper
- Test Light or Volt Meter
- Electric Drill
- 1-1/4" Hole Saw
- Small (10 amp or less) Battery Charger

5.0 PRE-INSTALLATION AND GENERAL HARNESS ROUTING GUIDELINES

The installation of your wire harness mainly consists in two parts:

1. The physical routing and securing of the wire harness, wires, and groups.
2. The proper connection of the individual circuits.

These two major tasks are not separate steps, but are integrated together. That is, you will route some wires and make some connections, route some more wires and make some more connections.

We cannot tell you how to physically route the harness in your automobile. That depends a great deal upon the particular make of automobile and to what extent you want to secure and conceal the harness. We do offer some general guidelines and routing practices starting in **Section 5.2**, GENERAL installation instructions in **Section 6.0**, and precise instructions concerning the electrical connections you will have to make beginning in **Section 7.0**. To help you begin thinking through the installation of your wire harness, read the following sections:

- 5.1** Familiarize yourself with the harness by locating each of the harness sections in the following list. (Whenever a particular harness section is referred to in these instructions it is shown "all caps": ENGINE SECTION A.) Note that, according to the particular harness you have purchased, some of these sections may not be present, and some are not labeled:

ACCESSORY SECTION SWITCHES	HEADLIGHT SECTION A
ACCESSORY SECTION B+	HEADLIGHT SECTION B
DIMMER SWITCH SECTION	IGNITION SWITCH SECTION
ENGINE SECTION A	INSTRUMENT PANEL SECTION
ENGINE SECTION (Single, 10 ga. Red wire)	RADIO SECTION
ENGINE SECTION	TAIL SECTION
TURN SIGNAL SECTION	

Note: For complete information concerning the individual circuits and wires that make up the harness SECTIONS, see **Section 11.0**.

- 5.2** Decide where the fuse block will be mounted.
5.3 Decide which of the following circuits you will be using in your system and where the harness groups or wires will be routed:

ROUTING LOCATION AND PLACEMENT

Emergency Flashers	
Horn	
Lights	
Wipers	
Coil	
Turn Signals	
Radio Ignition Switched Power	
Radio Constant Power	
Gauges	
Accessories	
Headlights	
Engine	
Dash	
Tail Lights	

- 5.4 A good exercise is to lay out the wire harness on the floor beside your automobile and identify all the SECTIONS. You will want to route the harness through and around open areas. Inside edges provide protection from hazards and also provide places for tie wraps, clips and other support.
- 5.5 Route the harness away from sharp edges, exhaust pipes, etc.
- 5.6 Plan where harness supports will be located. Allow enough slack at places where movement could occur (body to frame, frame to engine, etc.). Use a support every 12 inches unless the harness routes under the floor carpet.
- 5.7 At wire ends don't depend on the terminals to support the harness. The weight of the harness could cause terminals to disconnect or copper wire strands to break.
- 5.8 The wires should be bundled into groups. Use nylon ties, poly split loom, or tape.

6.0 HARNESS GENERAL INSTALLATION INSTRUCTIONS

6.1 Rough Installation

CAUTION: **DISCONNECT THE POWER FROM YOUR VEHICLE BY REMOVING THE NEGATIVE (BLACK) BATTERY CABLE FROM THE BATTERY.**

Note: Make no wire connections or permanent mounting of any kind at this time!

- 6.1.1 Position the fuse block in its mounting area.
- 6.1.2 Drill a 1-1/4" (1.25") hole near the fuse block for engine and headlight group wires to pass through (ENGINE SECTION, ENGINE SECTION A, SINGLE 10 GA. (Red wire #916), and HEADLIGHT SECTION A). **If Applicable.**
- 6.1.3 Install the Firewall grommet. Route engine and headlight group wires through the grommet and position the harness groups in the areas decided upon in **Sections 5.3** and **5.1**.
- 6.1.4 Route dash group (ACCESSORY SECTION B+, ACCESSORY SECTION SWITCHES, HEADLIGHT SECTION B, INSTRUMENT PANEL SECTION and RADIO SECTION) upward to rear of dash and temporarily tie in place.
- 6.1.5 Position rear group, the TAIL SECTION, in the area decided upon in **Sections 5.3**.

6.2 Harness Attachment

Note: Harness routing and shaping is and should be a time-consuming task. Taking your time will enhance the beauty of your installation. Please be patient and TAKE YOUR TIME!

- 6.2.1 Permanently mount the fuse block using the four bolts, lock washers and nuts included.

NOTE: The fuse block does **NOT** have to be grounded.

NOTE: The fuse block and legs fit loosely together so that once the fuse block mounting hardware has been tightened the fuse block and mounting legs will all tighten and hold each other securely in place.

- 6.2.2 Mold harness groups to the contour of floor pan, firewall, and any other area where wires or harness groups are routed. Remember to route the harness away from sharp edges, exhaust pipes, etc.
- 6.2.3 Attach harness groups to your automobile with clips or ties starting at the fuse block and working toward the rubber grommet for the front groups and along the floor pan or frame for the rear group. The dash wires should be routed out of the way of any under-dash obstacles, such as radio, etc.

Note: Do not tighten tie wraps and mounting devices at this time. Make all harness attachments LOOSELY.

- 6.2.4 When used every 1-1/2" or so on the visible areas of the harness, the plastic wire ties make a very attractive assembly. A tie installed in other areas every 6" or so will hold the wires in place nicely. Remember to take your time!

6.3 Grounding the Automobile

A perfectly and beautifully wired automobile will nevertheless have bugs and problems if everything is not properly grounded. Do not go to the careful effort of installing a quality wire harness only to neglect proper grounding.

Note: The Painless Wire Harness Kit includes no ground wire except the black wire from the two headlamp connectors. You must supply ground wire (14-16 gauge) for all other circuits.

- 6.3.1 Connect a Ground Strap or Cable (even a 10-gauge wire is too small) from the Negative Battery terminal to the automobile chassis (frame).
- 6.3.2 Connect a Ground Strap from the Engine to the chassis. **DO NOT RELY UPON THE MOTOR MOUNTS TO MAKE THIS CONNECTION.**
- 6.3.3 Connect a Ground Strap from the Engine to the Body.
- 6.3.4 If you have a fiberglass body you should install a terminal block to ground all your Gauges and Accessories. Ground the Terminal Block with at least a 12-gauge wire to the chassis.

6.4 Terminal Installation and Making Connections

*Note: In the following steps you will be making the circuit connections. Before you start, you should carefully read **Sections 7.0 through 10.0**, as appropriate, and continually refer to **Section 11.0**, **DOUBLE-CHECKING** your routing and length calculations before cutting any wires and making connections. Give special attention to Turn Signal and Ignition Switch connections. These can be somewhat confusing.*

- 6.4.1 Have all needed tools and connectors handy.
- 6.4.2 Select the correct size terminal for the wire and stud application.
- 6.4.3 Determine the correct wire length and cut the wire. Remember to allow enough slack in the harness and wires at places where movement could possibly occur, such as automobile body to frame, frame to engine, etc. **Double-check your calculations.**
- 6.4.4 Strip insulation away from wire. Strip only enough necessary for the type of terminal lug you are using.

Note: In the following step, make sure that the terminal is crimped with the proper die in the crimping tool. An improper crimp will NOT make a good connection.

- 6.4.5 Crimp the terminal onto the wire.

CAUTION: DO NOT OVER-CRIMP!

- 6.4.6 Connecting the harness throughout the groups is a redundant process. Make sure that each wire is **FIRST** properly routed and **THEN** attach. **DO NOT ATTACH FIRST THEN ROUTE AFTERWARD.**
- 6.4.7 When all wires are attached, tighten the mounts and ties to secure harness permanently.

6.5 Testing The System

- 6.5.1 Use a small (10 amp or less) battery charger to power up the vehicle for circuit testing. If there is a problem anywhere, the battery charger's low amperage and internal circuit breaker will provide circuit protection.

CAUTION: IF YOU HAVE NOT YET DISCONNECTED THE BATTERY FROM THE AUTOMOBILE, DO SO NOW! DO NOT CONNECT THE BATTERY CHARGER WITH THE BATTERY CONNECTED.

Connect the battery charger's **NEGATIVE** output to the automobile chassis or engine block and its **POSITIVE** output to the automobile's positive battery terminal.

- 6.5.2 **INDIVIDUALLY** turn on each light, ignition, wiper circuit, etc. and check for proper operation.

Note: The turn signals will not flash properly if you do not have both the front and rear bulbs installed and connected.

- 6.5.3 When all circuits check out **THEN** attach the battery cable to the battery for vehicle operation.

7.0 GM - SPECIFIC CIRCUIT CONNECTIONS

Note: Your alternator may not appear exactly as represented in the **Figures**. The circuits are wired the same way, though.

7.1 Early GM Alternator (before 1969) - External Regulator. See Figure 7-1.

- 7.1.1 With a short 16-gauge jumper wire, connect Voltage Regulator terminals 3 & 4 together. Connect ENGINE SECTION wire #914 (wht) to Voltage Regulator terminal 3 or 4.
- 7.1.2 Connect ENGINE SECTION wire #915 (red) to the Alternator Output lug (Bat).
- 7.1.3 Connect a 14-gauge wire from Voltage Regulator terminal 2 to Alternator terminal R. Connect a 14-gauge wire from Voltage Regulator terminal F to Alternator terminal F.
- 7.1.4 Connect a 16-gauge ground wire from the Alternator Ground lug (G) to chassis ground.

7.2 Late GM Alternator (after 1972) - Internal Regulator. See Figure 7-2.

- 7.2.1 Connect ENGINE SECTION wire #914 (wht) to Alternator terminal 1. Connect ENGINE SECTION wire #915 (red) to the Alternator Output lug (Bat).

CAUTION: IF USING AN ALTERNATOR WITH AN OUTPUT LARGER THAN 65 AMPS, YOU WILL ALSO NEED TO USE JUMPER WIRE #960 (RED) INCLUDED IN BOX. THE WIRE END WITH THE RING TERMINAL AND RUBBER BOOT WILL CONNECT TO THE ALTERNATOR OUTPUT LUG. ROUTE THE OTHER END TO THE STARTER SOLENOID. CUT THE WIRE AND CRIMP ON A RING TERMINAL. INSTALL ON SOLENOID TERMINAL WITH CABLE COMING FROM BATTERY. SEE FIGURE 7-2B. YOU WILL NOW HAVE TWO (2) HEAVY WIRES ON THE OUTPUT POST.

- 7.2.2 Connect a short 14-gauge jumper wire from Alternator terminal 2 to the Alternator Output lug (Bat).
- 7.2.3 A connector and terminal spades for late GM Alternators are included in the parts box.

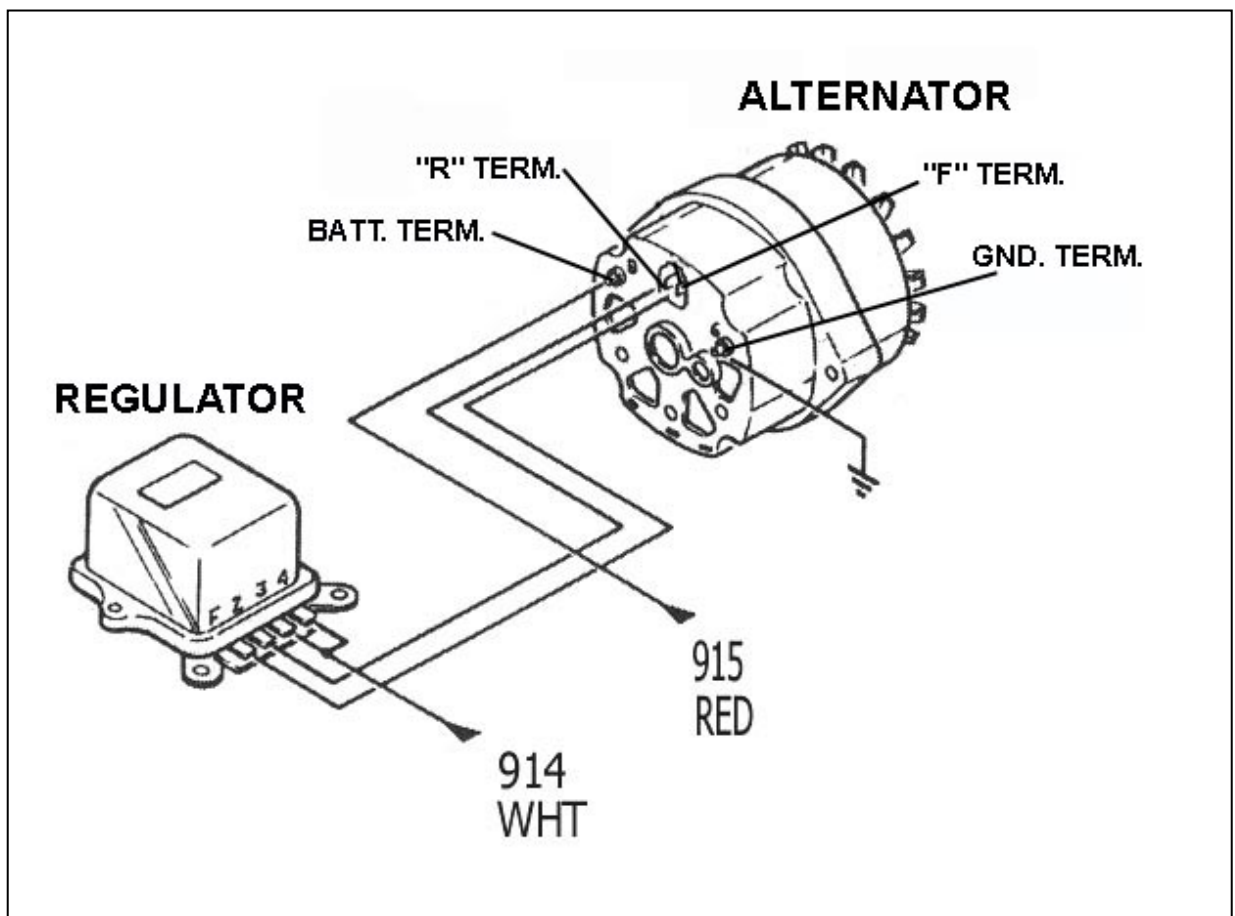

Figure 7-1 Early GM Alternator - External Regulator

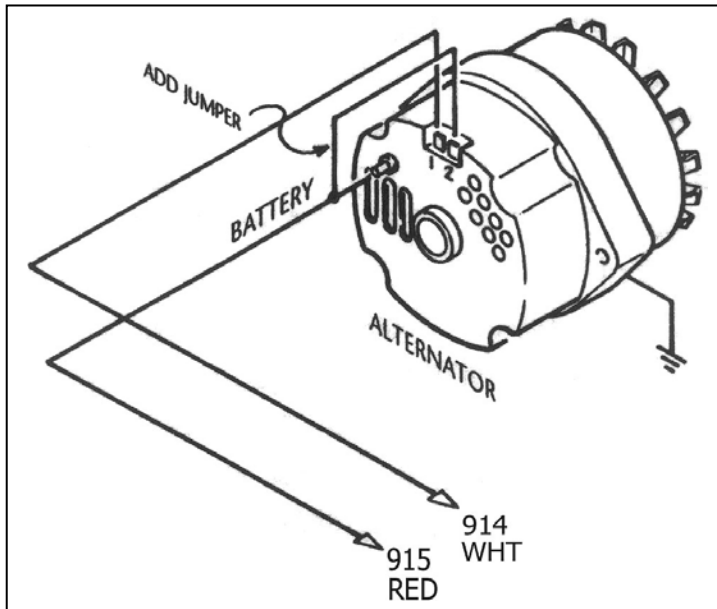

Figure 7-2A Late GM Alternator - Internal Regulator

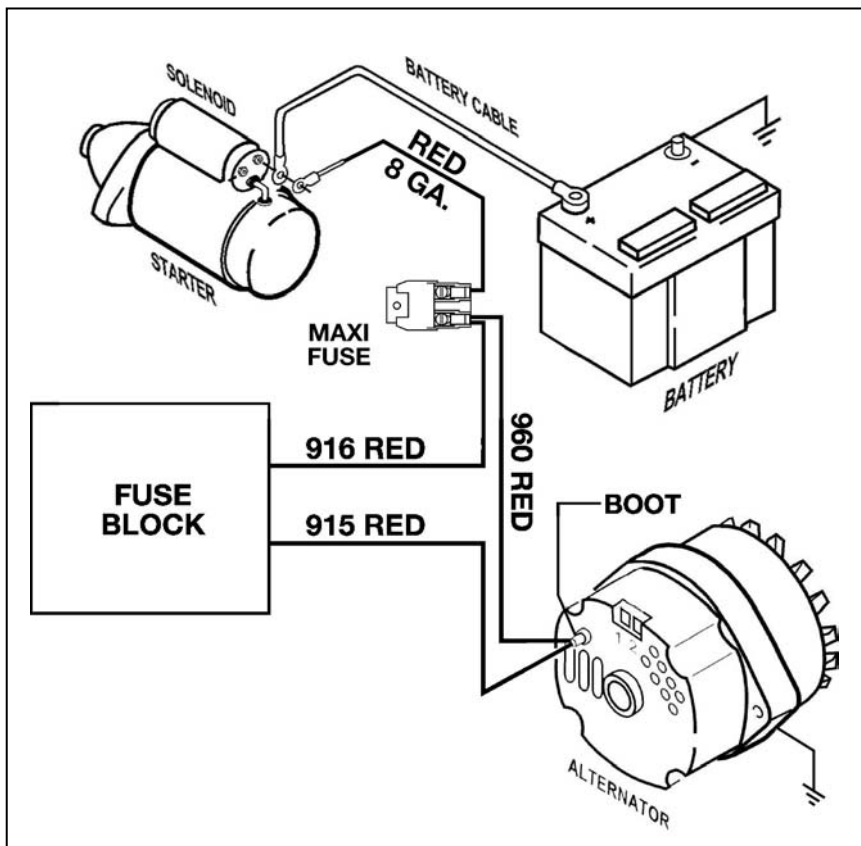

Figure 7-2B High Output Wire

7.3 GM One-Wire Alternator.

7.3.1 Connect ENGINE SECTION wire #915 (red) to the Alternator Output lug (Bat).

CAUTION: IF USING AN ALTERNATOR WITH AN OUTPUT LARGER THAN 65 AMPS, SEE CAUTION ON PAGE 6 UNDER PARAGRAPH 7.2.1.

7.3.2 Insulate and stow ENGINE SECTION wire #914 (wht). Do not install jumper wire. No wires are connected to Alternator terminals 1 & 2.

7.3.3 When using a 1-wire alternator you must use a voltmeter or ammeter. A WARNING LIGHT CANNOT BE WIRED IN.

7.4 GM Ignition (Start/Run) System. See Figure 7-4.

Note: If you are going to install an ammeter, see **Section 10.3** first.

7.4.1 With crimping tool, attach Maxi Fuse (**Figure 7-3**) onto end of ENGINE SECTION (single) 10 ga. wire #916 (red) AFTER having routed wire from the Fuse Panel to the Starter Solenoid. This serves as a fuse to protect the entire harness. DO NOT OMIT IT!

7.4.2 Connect wire #916 - with Maxi Fuse installed - to the Starter Solenoid Battery terminal. This is the same lug that the large red cable from the battery is normally connected to.

7.4.3 Connect ENGINE SECTION A wire #919 (pur) to the Starter Solenoid Start (S) terminal. (See illustration on page 31)

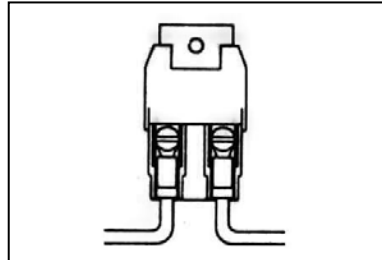

Figure 7-3 Maxi Fuse

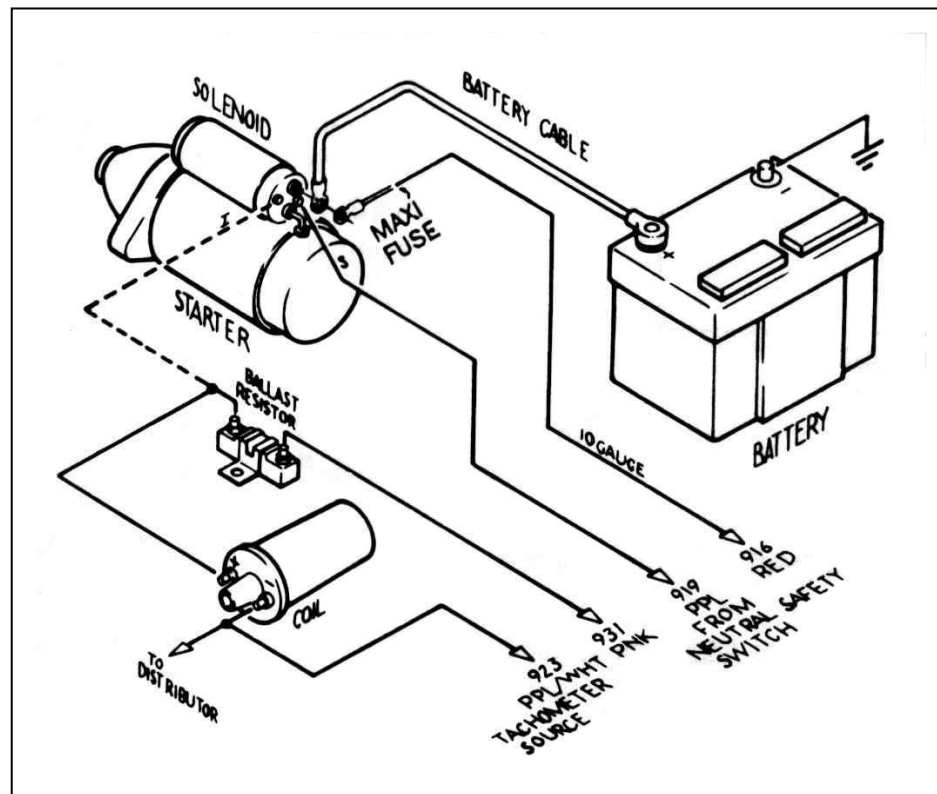

Figure 7-4 GM Ignition (Start-Run) System

7.4.4 If you are using the Ballast Resistor, mount it away from other wiring or hoses. The Ballast Resistor gets very hot during operation. Connect ENGINE SECTION A wire #931 (pink) to one end of the Ballast Resistor. Connect the other end of the Ballast Resistor to the Ignition Coil B+ terminal with 14-gauge wire (you may have enough pink wire left over to accomplish this). If you are not using a Ballast Resistor, connect wire #931 directly to the Ignition Coil B+ terminal.

Note: The ballast resistor has been deleted from this kit due to lack of consumer usage. If one is needed in your application, please call Painless Performance at 800-423-9696 for assistance.

Important Note! For HEI systems route wire #920 (pink) to the Distributor and attach it to the terminal labeled BAT. No Ballast Resistor is required.

- 7.4.5** The Ignition Coil NEGATIVE (-) terminal is connected to the Distributor. Also Connect ENGINE SECTION A wire #923 (pur/wht) to the Ignition Coil NEGATIVE (-) terminal. This is the tachometer source. If you are not using a tachometer, insulate and stow wire #923.
- 7.4.6** A 14-gauge wire connected from the Starter Solenoid Ignition (I) terminal to the ignition coil side of the Ballast Resistor is optional. This wire (the dashed line in **Figure 7-4**) serves as a ballast resistor BYPASS during engine starting. However, if the starter solenoid shorts out, which is not unusual, the engine will stop running and will not restart as long as this wire is connected. You may therefore choose to omit it. If you are not using a Ballast Resistor, leave the Starter Solenoid Ignition (I) terminal unconnected and do not install the bypass wire.

7.5 Steering Column Wiring - Turn Signal & Ignition Switch Connectors

- 7.5.1** There are two different plugs on most GM tilt columns. The difference is in the length of the male plug that is mounted ON THE COLUMN. One plug is 3-7/8" (3.875") long and the other is 4-1/4" (4.250"). This is only a difference of 3/8" (0.375"), so measure the plug carefully. The Wire Harness Kit has included two different female connectors to mate with the column-mounted plug. See **Figure 7-5** to determine which female connector is correct for your automobile.

Take the TURN SIGNAL SECTION wires, cut to length and install terminals provided. Choose the proper plug and install the terminals according to **Table 7-1**, as shown in **Figure 7-5**. The GM wire color codes have been included for reference.

*Note: The terminals will only insert into the connector ONE WAY, as shown in **Figure 7-5**. Make certain you are inserting the wire into the CORRECT LOCATION as the terminals are difficult if not impossible to remove once inserted.*

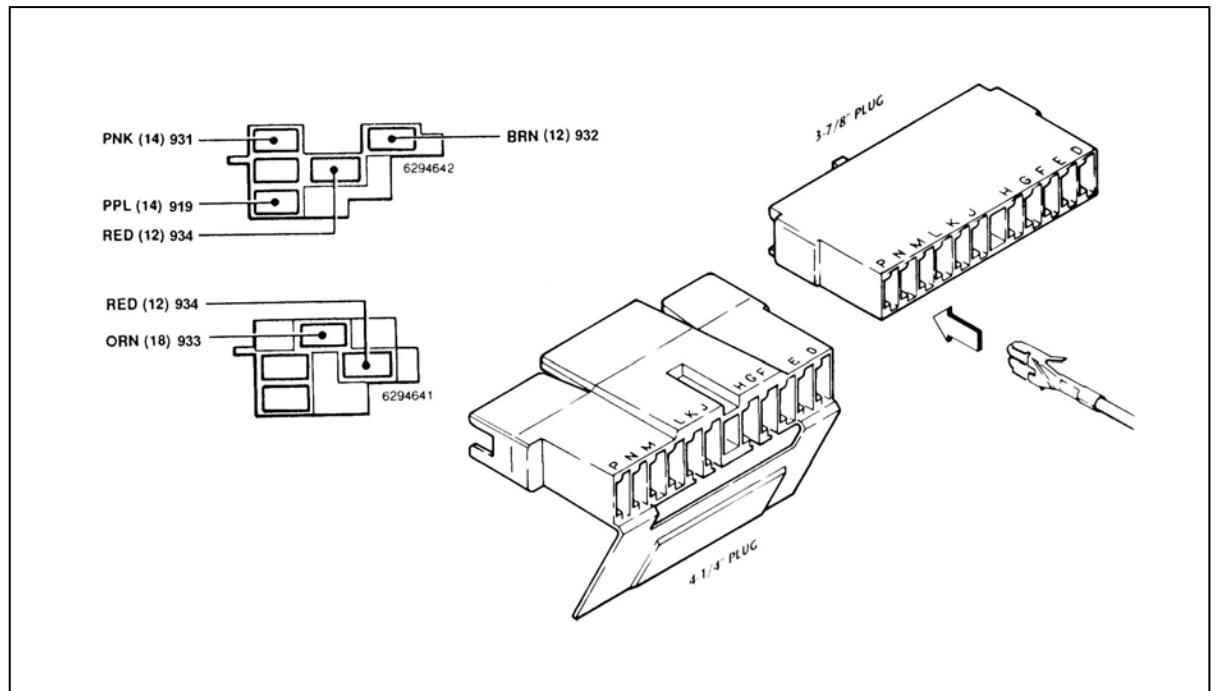

Figure 7-5 GM Turn Signal Connectors

- 7.5.2** The Wire Harness Kit has included two connectors to mate with the GM column-mounted ignition switch. Take the ignition switch wires, cut to length and install terminals provided. See **Table 7-1** and **Figure 7-5** for color codes, wire numbers, and wire designations for the Ignition Switch Connectors.
- 7.5.3** **IGNITION SWITCH SECTION wire #919 (pur) needs to be cut and spade lugs installed on the GM keyed steering column wiring. These spade lugs are to be connected to the Neutral Safety Switch at the base of the steering column. If using a neutral safety switch on a floor shifter or in the transmission, take and route the #919 (pur) wire to the neutral safety switch, cut and connected to it, then continued on to the starter solenoid.**
- 7.5.4** The harness does not support seat belt buzzers or key alarms.
- 7.5.5** To supply power to a throttle body or tuned port fuel injection use ENGINE SECTION A wire #920 (pnk) as the fused ignition power source.

TURN SIGNAL SECTION

GM Color	Designation	Painless Wire No.	Painless Color	Turn Signal Connector
Blk	Horn	953	Blk	G
Lt.Blu	LF Turn Signal	926	Lt.Blu	H
Dk.Blu	RF Turn Signal	925	Dk.Blu	J
Brn	Hazard Flasher	951	Brn	K
Pur	Turn Flasher	952	Pur	L
Ylw	LR Turn Signal	949	Ylw	M
Grn	RR Turn Signal	948	Grn	N
Wht	Stop Lamp Switch	918	Wht	P

IGNITION SWITCH SECTION

		Painless Wire No.	Painless Color
Pur/Wht	Ignition Start	919	Pur
Pnk	Ignition Coil	931	Pnk
Brn	Accessory Fuse Panel	932	Brn
Orn	Ignition Switched Fuse Panel	933	Orn
Red*	Battery B+	934	Red
Red*	Battery B+	934	Red

* See note 6 on page 28

Table 7-1 GM Ignition & Turn Signal Wiring

8.0 FORD - SPECIFIC CIRCUIT CONNECTIONS

8.1 Ford Alternator (2 configurations). See Figure 8-1A.

Note: Your Alternator may not appear exactly as represented in **Figure 8-1A**. The circuits are wired the same way, though.

8.1.1 Connect ENGINE SECTION wire #915 (red) to the Alternator Output lug (Bat). Connect ENGINE SECTION wire #914 (wht) to the Voltage Regulator (I) terminal.

CAUTION: IF USING AN ALTERNATOR WITH AN OUTPUT LARGER THAN 65 AMPS, YOU WILL ALSO NEED TO USE JUMPER WIRE #960 (RED), INCLUDED IN BOX. THE WIRE END WITH THE RING TERMINAL AND RUBBER BOOT WILL CONNECT TO THE ALTERNATOR OUTPUT LUG. ROUTE THE OTHER END TO THE STARTER RELAY. CUT THE WIRE AND CRIMP ON A RING TERMINAL. INSTALL ON RELAY TERMINAL WITH CABLE COMING FROM BATTERY. SEE FIGURE 8-1B.

8.1.2 Connect a 14-gauge jumper from the Voltage Regulator A terminal to the Alternator Output lug (Bat).

8.1.3 Connect a 14-gauge wire from the Voltage Regulator S terminal to the Alternator Stator (S) terminal. Connect a 14-gauge wire from the Voltage Regulator F terminal to the Alternator Field (F) terminal.

8.1.4 Connect the Alternator Ground lug and the Voltage Regulator to chassis ground.

8.1.5 An alternate (and less-used) method is to omit the Alternator Stator wire, install a 14-gauge jumper across Voltage Regulator terminals A & S, and connect wire #914 to either the A or S terminal of the Voltage Regulator. The FIELD wire and wire #915 are connected as above. Do **NOT** install a jumper as in **Paragraph 8.1.2**. The Voltage Regulator Ignition (I) terminal is not connected. Install ground wires as in **Paragraph 8.1.4**. This alternate configuration is illustrated in dashed lines in **Figure 8-1A**.

8.2 Ford Ignition (Start/Run) System. See Figure 8-2.

Note: If you are going to install an ammeter, see **Section 10.3** first.

Note: Original ignition module wire should be retained if possible. Connectors for the module are no longer serviced.

- 8.2.1** With crimping tool, attach the Maxi Fuse (**Figure 7-3**) onto end of ENGINE SECTION (single) 10 ga. wire #916 (red) AFTER having routed wire (with or without ammeter) from the Fuse Panel to the Starter Relay. This serves as a fuse to protect the entire harness. DO NOT OMIT IT!
- 8.2.2** Connect wire #916 - with Maxi Fuse installed - to the Starter Relay Battery terminal. This is the same lug that the large red cable from the battery is normally connected to.
- 8.2.3** Connect ENGINE SECTION A wire #919 (pur) to the Starter Relay Start (S) terminal.

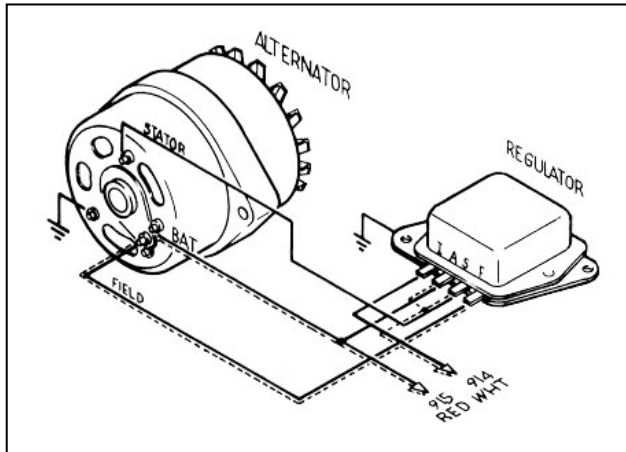

Figure 8-1A Ford Alternator (2 configurations)

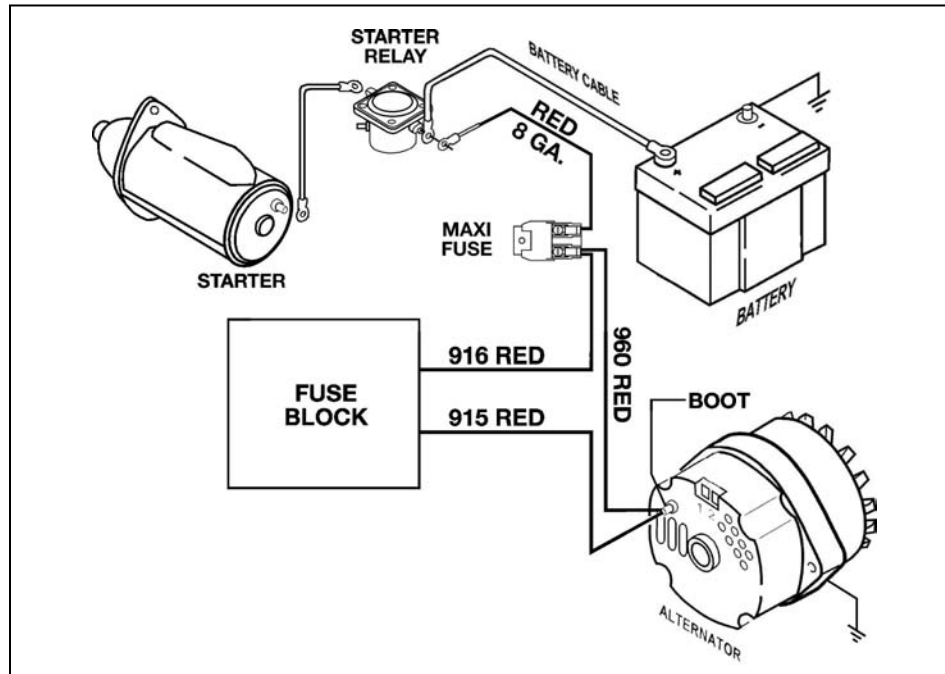

Figure 8-1B High Output Wire

- 8.2.4** If you are using the Ballast Resistor, mount it away from other wiring or hoses. The Ballast Resistor gets very hot during operation. Connect ENGINE SECTION A wire #920 (pnk) to one end of the Ballast Resistor. Connect the other end of the Ballast Resistor to the Ignition Coil B+ terminal with 14-gauge wire (you may have enough pink wire left over to accomplish this). If you are using a Ballast Resistor, connect wire #920 directly to the Ignition Coil B+ terminal.

Note: The Ballast Resistor has been deleted from this kit due to lack of consumer usage. If one is needed in your application, please call Painless Performance at 800-423-9696 for assistance.

- 8.2.5** The Ignition Coil NEGATIVE (-) terminal is connected to the Distributor. Also connect ENGINE SECTION A wire #923 (pur/wht) to the Ignition Coil NEGATIVE (-) terminal. This is the tachometer source. If you are not using a tachometer, insulate and stow wire #923.
- 8.2.6** Connect a 14-gauge wire from the Starter Relay Ignition (I) terminal to the ignition coil side of the Ballast Resistor. This wire serves as a ballast resistor BYPASS during engine starting. If you are not using a ballast resistor, leave the Starter Relay Ignition (I) terminal unconnected and do not connect the bypass wire.
- 8.2.7** Be sure the large, red battery cable is connected from the other side of the Starter Relay to the Starter Motor.

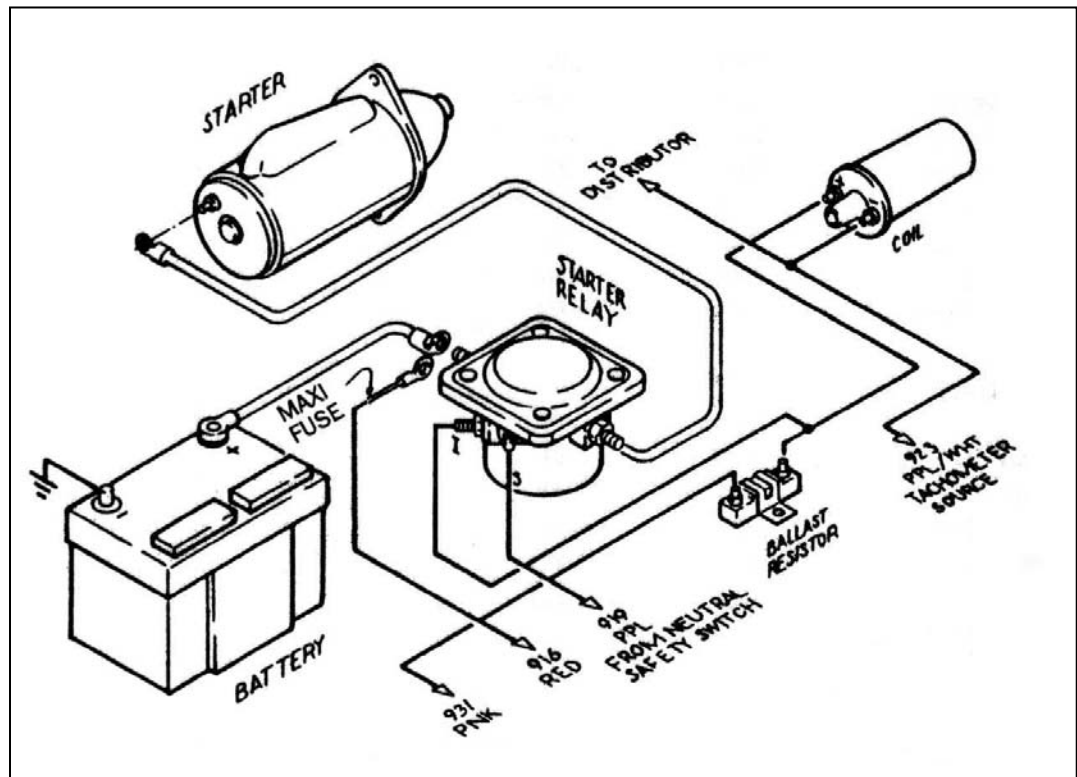

Figure 8-2 Ford Ignition (Start/Run) System

8.3 Steering Column Wiring - Turn Signal Connections

8.3.1 Connect the nine (9) TURN SIGNAL SECTION wires to your automobile's existing Turn Signal Connector according to **Table 8-1**. Ford wire color codes are provided for reference. Ford has not been uniform in assigning wire colors over the years; so you may find that the wire colors in your existing Ford harness differ from those shown.

8.3.2 If there is any doubt, be on the safe side. Trace the wire(s) with an ohmmeter, circuit tester, or test light. DON'T GUESS!

Note: Disconnect one end of the wire you are tracing. If you leave it connected, there is the possibility of tracing it back through some other circuit and getting false results.

8.3.3 Connect the Horn Ground wire to chassis ground. The Painless harness has no corresponding ground wire, nor does it support seat belt buzzers or key alarms.

8.4 Steering Column Wiring - Ignition Switch Connections

8.4.1 Connect the wires of the IGNITION SWITCH SECTION according to **Table 8-1**. **Figure 8-3** represents three (certainly not all) possible Ford ignition switch connector configurations and how they should be wired.

Note: The connectors are shown from the wire side, NOT the connection side. It is important to understand the difference.

Again, trace the wires if in doubt.

8.4.2 On some Fords, the Ignition Switch is designed to bypass the ballast resistor during start. In **Table 8-1**, the red/blu wire supplies power to the coil, bypassing the ballast resistor when the switch is in the "Start" position. Once the engine has started and the switch is released (Run), power is supplied to the coil (through the ballast resistor) by the (variously-colored) wire shown. Jumper these two terminals to the Ignition Switch Connector and connect IGNITION SECTION wire #931 (pnk) to one or the other. **DO NOT ROUTE AN ADDITIONAL WIRE.** The ballast resistor bypass circuit was wired at **Paragraph 8.2.4**.

8.4.3 IGNITION SWITCH SECTION wire #919 (pur) needs to be routed to the neutral safety switch, cut and connected to it. If the switch is mounted on the floor shifter, add some length of wire to reach it. FOR SAFETY, PLEASE USE A NEUTRAL SAFETY SWITCH!

TURN SIGNAL SECTION

Ford Color	Designation	Painless Wire No.	Painless Color
Grn	Stop Light	918	Wht
Wht/Blu	RF Turn Signal	925	Blu
Grn/Wht	LF Turn Signal	926	Lt.Blu
Orn/Blu	RR Turn Signal	948	Grn
Grn/Orn	LR Turn Signal	949	Ylw
Wht/Red	Hazard Flasher	951	Brn
Blu	Turn Flasher	952	Pur
Ylw	Horn	953	Blk
Dk.Blu	Horn Ground	Gnd	----

IGNITION SWITCH SECTION

Brn/Pur or Wht/Blu ¹	Start	919	Pur
Wht/Grn, Red/Grn, Wht/Blu or Brn/Pur	Ignition Coil (run)	931	Pnk
Red/Blu	Ignition Coil (start)	2	----
Blk/Grn or Blk/Ylw	Accessory Fuse Panel	932	Brn
Gry, Gry/Ylw, or Blk	Ignition Switched Fuse Panel	933	Orn
Ylw	Battery B+	934	Red

NOTES:

1. Wire may be one of the colors shown, or some other color. See **Paragraph 8.3.1.**
2. Jumper to wire #931. See **Paragraph 8.4.2.**

Table 8-1 Ford Ignition and Turn Signal Wiring

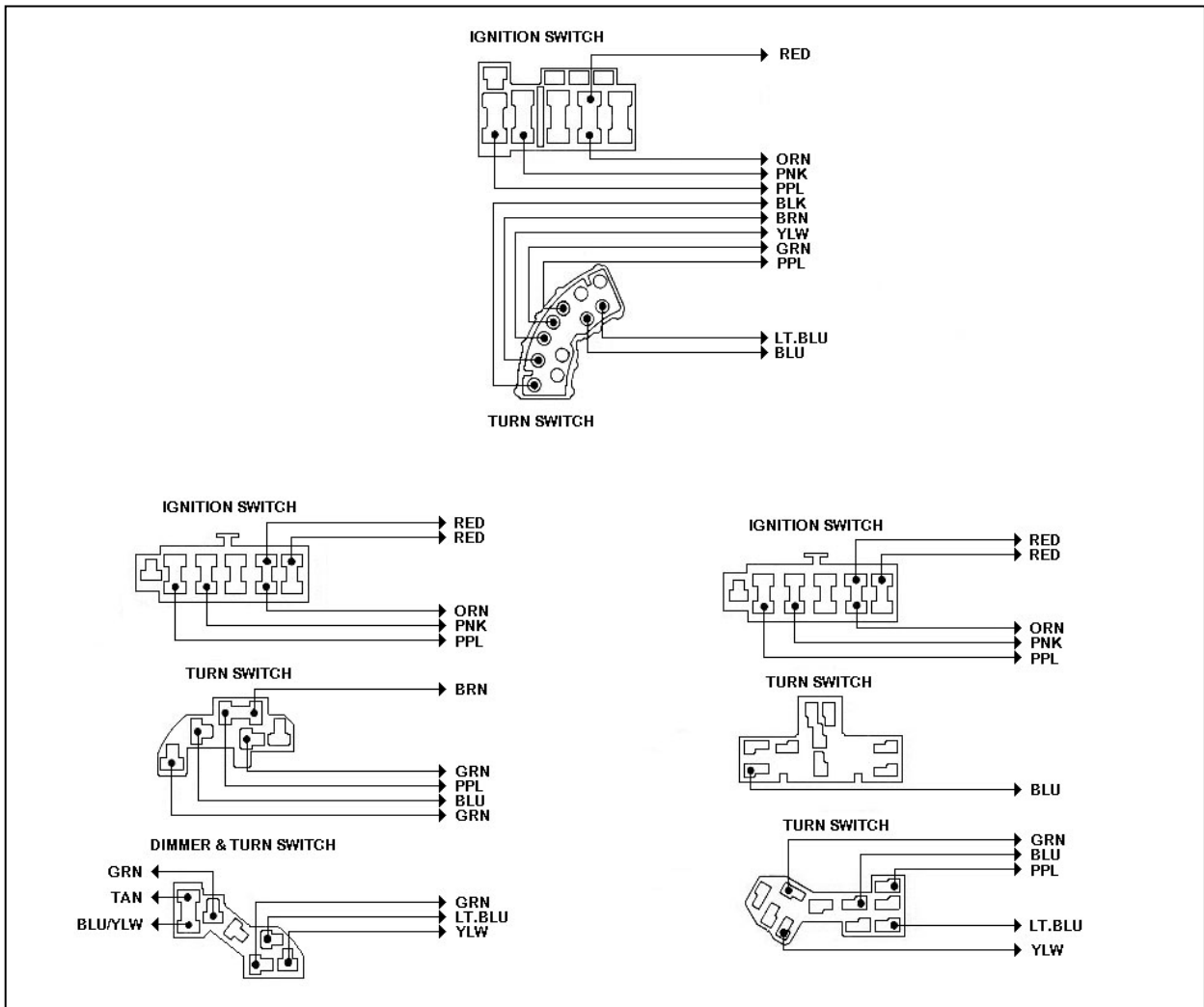

Figure 8-3 Ford Ignition Switch Connectors (See note on Page 10, Section 8.2)

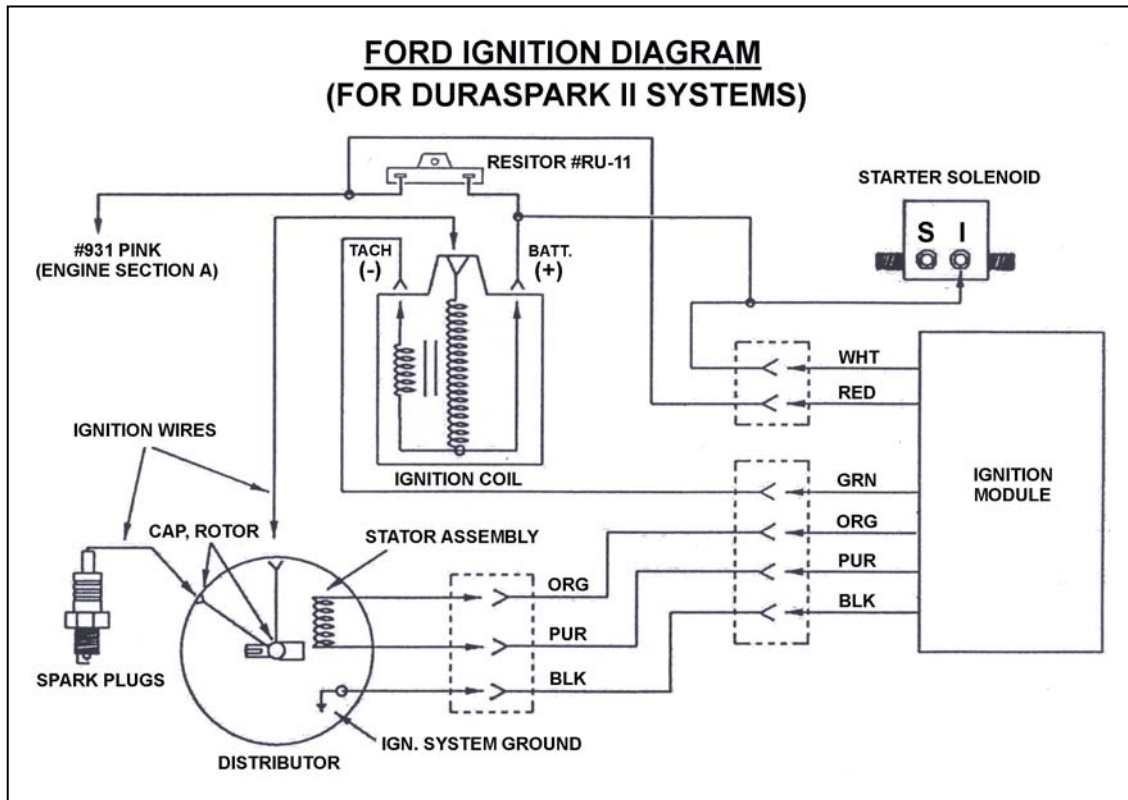

Figure 8-4 Ford Ignition Diagram (Duraspark II Systems)

9.0 MOPAR - SPECIFIC CIRCUIT CONNECTIONS

9.1 Mopar Alternator. See Figure 9-1

Note: Your Alternator may not appear exactly as represented in **Figure 9-1A**. The circuits are wired the same way, though.

- 9.1.1** Mopar uses one of two kinds of voltage regulators: An electronic regulator and a mechanical one. The electronic voltage regulator is represented in **Figure 9-1A**. It does not matter how the two terminals are connected, so long as they are BOTH connected. The mechanical regulator has terminals marked "F" (Field) and "I" (Ignition). In contrast to the electronic regulator, it DOES make a difference how the mechanical regulator is connected.
- 9.1.2** Connect ENGINE SECTION wire #914 (wht) to the Alternator Field (F) terminal as shown in **Figure 9-1A**. Connect ENGINE SECTION wire #915 (red) to the Alternator Output lug (Bat).
- CAUTION: IF USING AN ALTERNATOR WITH AN OUTPUT LARGER THAN 65 AMPS, YOU WILL ALSO NEED TO USE JUMPER WIRE #960 (RED), INCLUDED IN BOX. THE WIRE END WITH THE RING TERMINAL AND RUBBER BOOT WILL CONNECT TO THE ALTERNATOR OUTPUT LUG. ROUTE THE OTHER END TO THE STARTER. CUT THE WIRE AND CRIMP ON A RING TERMINAL. INSTALL ON STARTER TERMINAL WITH CABLE COMING FROM BATTERY. SEE FIGURE 9-1B.**
- 9.1.3** Connect a 14-gauge wire from the Alternator terminal where wire #914 is connected to either of the ELECTRONIC Voltage Regulator terminals OR terminal (I) of the MECHANICAL Voltage Regulator. On existing Mopar harnesses, this would be a blue wire.
- 9.1.4** Connect a 14-gauge wire from the other Alternator Field terminal (as shown in **Figure 9-1A**) to the second terminal of the ELECTRONIC Voltage Regulator OR terminal (F) of the MECHANICAL Voltage Regulator. On existing Mopar harnesses, this would be a green wire.
- 9.1.5** Finally, be sure BOTH the alternator and the voltage regulator itself are grounded.

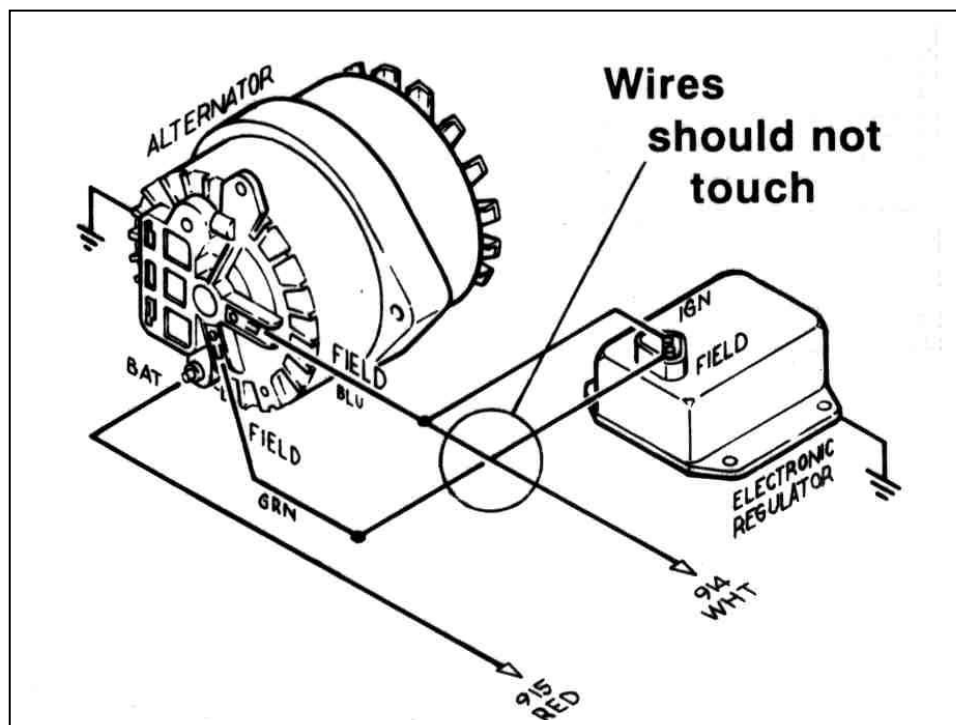

Figure 9-1A Mopar Alternator

9.2 Mopar Ignition (Start/Run) System. See Figure 9-2

Note: If you are going to install an ammeter, see **Section 10.3** first.

- 9.2.1** Connect ENGINE SECTION (single) 10-gauge red wire #916 (with or without ammeter) to the Starter Relay Battery Terminal. Retain excess wire.

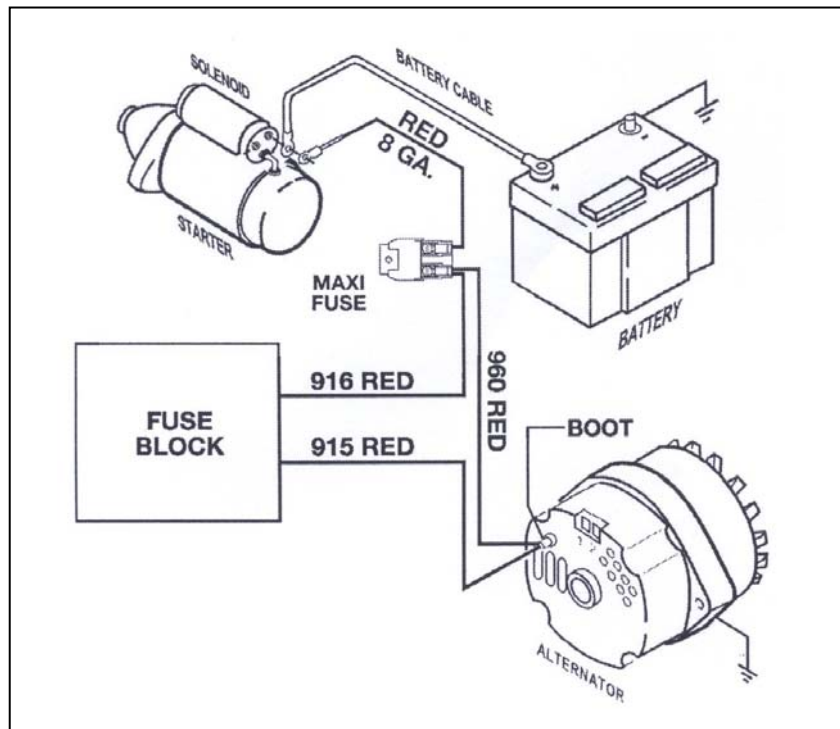

Figure 9-1B High Output Wire

- 9.2.2** With crimping tool, attach the Maxi Fuse (**Figure 7-3**) onto remaining length of red 10-gauge wire. It serves as a fuse to protect the entire harness. **DO NOT OMIT IT!** Connect this wire from the Starter Motor Battery terminal, as shown in **Figure 9-2**. **USE ONLY 10-GAUGE WIRE.**
- 9.2.3** Connect ENGINE SECTION A wire #919 (pur) to the Starter Relay Ignition (I) terminal.
- 9.2.4** Connect a 14-gauge wire from the Starter Relay Ground (G) terminal to the center terminal of the transmission mounted Neutral Safety Switch. Older Mopar neutral safety switches have only one terminal. On newer switches, the two outside terminals are for backup lights. Use existing wiring to connect these two terminals as shown in **Figure 9-2**.
- 9.2.5** If the Neutral Safety Switch is mounted in the floor shifter, connect the Starter Relay Ground (G) terminal to chassis ground. Refer to **Paragraph 9.4.3** to wire the Neutral Safety Switch.
- 9.2.6** If you are using the Ballast Resistor, mount it away from other wiring or hoses. The ballast resistor gets very hot during operation. Connect ENGINE SECTION A wire #920 (pnk) to one end of the Ballast Resistor. Connect the other end of the ballast resistor to the Ignition Coil POSITIVE (+) terminal with 14-gauge wire (you may have enough pink wire left over to accomplish this). If you are not using a Ballast Resistor, connect wire #920 directly to the Ignition Coil B+ terminal.

Note: The Ballast Resistor has been deleted from this kit due to lack of consumer usage. If one is needed in your application, please call Painless Performance at 800-423-9696 for assistance.

- 9.2.7** Connect a 14-gauge wire from the Starter Relay Ignition (I) terminal to the ignition coil side of the Ballast Resistor. This wire serves as a ballast resistor BYPASS during engine starting. You must add a diode (8 amp min., 100 PIV) to this wire as shown in **Figure 9-2**. If you are not using a ballast resistor, do not connect this wire.
- 9.2.8** The Ignition Coil NEGATIVE (-) terminal is connected to the Distributor. Also connect ENGINE SECTION A wire #923 (pur/wht) to the Ignition Coil NEGATIVE (-) terminal. This is the tachometer source. If you are not using a tachometer, insulate and stow wire #923.
- 9.2.9** Be sure the large, red battery cable is connected from the Battery to the Starter Motor Battery terminal (the same place the Maxi Fuse is connected).

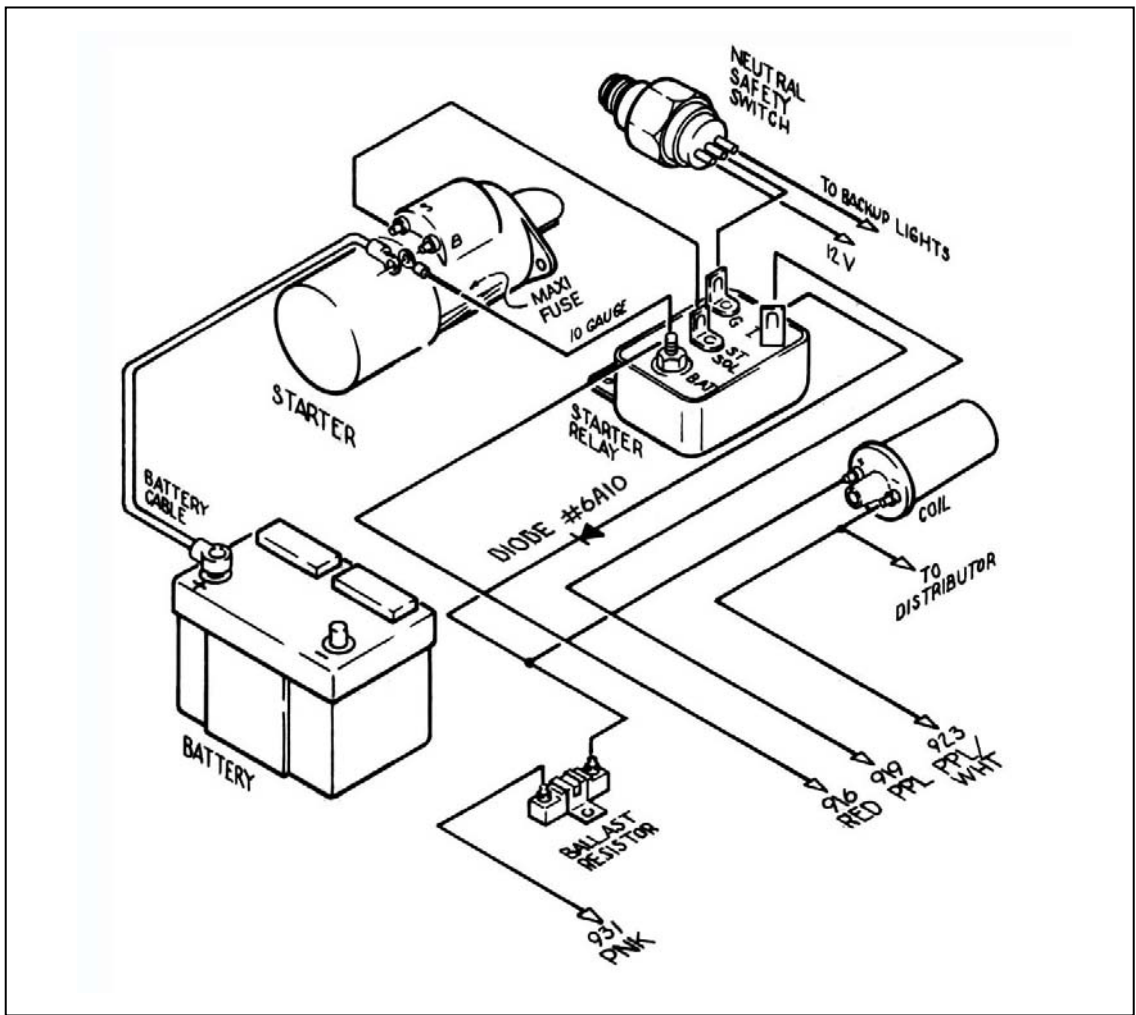

Figure 9-2 Mopar Ignition (Start/Run) System

9.3 Steering Column Wiring - Turn Signal Connections

Refer to **Table 9-1**. Check your existing wiring (by tracing the wire, if necessary) against the data given.

9.3.1 Connect the nine (9) wires of the TURN SIGNAL SECTION to your automobile's existing Turn Signal Connector according to **Table 9-1**. Mopar wire color codes for a number of years are provided for reference. Mopar has not been uniform in assigning wire colors over the years; so you may find that the wire colors in your existing Mopar harness differ from those shown.

9.3.2 If there is any doubt, be on the safe side. Trace the wire(s) with an ohmmeter, circuit tester, or test light. DON'T GUESS!

Note: Disconnect one end of the wire you are tracing. If you leave it connected, there is a possibility of tracing it back through some other circuit and getting false results.

9.3.3 If your existing Turn Signal Connector requires a Horn Ground wire, install one. The TURN SIGNAL SECTION has no ground wire, nor does it support seat belt buzzers, key alarms, or shifter lights.

9.4 Steering Column Wiring - Ignition Switch Connections

9.4.1 Connect the wires of the IGNITION SWITCH SECTION according to **Table 9-1**.

9.4.2 IGNITION SWITCH SECTION wire #919 (pur) is to be connected to a Neutral Safety Switch. However, Mopar switches are mounted in the transmission. The transmission-mounted neutral safety switch was wired at **Paragraph 9.2.4**. FOR SAFETY, PLEASE USE A NEUTRAL SAFETY SWITCH!

9.4.3 If the switch is mounted on a floor shifter, route the #919 purple (pur) wire to the neutral safety switch, cut and connect to it.

1970-74 WITHOUT TILT COLUMN

TURN SIGNAL CONNECTOR

Mopar Color	Designation	Painless Wire No.	Painless Color
Wht	Stop Light Switch	918	Wht
Tan	RF Turn Signal	925	Blu
Grn	LF Turn Signal	926	Lt.Blu
Brn	RR Turn Signal	948	Grn
Grn	LR Turn Signal	949	Ylw
Pnk	Hazard Flasher	951	Brn
Red	Turn Flasher	952	Pur
Blk	Horn	953	Blk

IGNITION SWITCH CONNECTOR

Ylw ¹	Ignition Start	919	Pur
Brn	Ignition Coil	931	Pnk
Blk	Accessory Fuse Panel	932	Brn
Blu	Ignition Switched Fuse Panel	933	Orn
Red	Battery B+	934	Red
Vio	Ground	----	----
Ylw ²	Buzzer Switch	3	----
Ylw ²	Buzzer Switch	3	----
Orn	Gear Shift Lamp	3	----

NOTES:

1. 12 gauge wire
2. 20 gauge wire
3. The Painless harness does not support these.

Table 9-1 Mopar Ignition and Turn Signal Wiring 1 of 2

TURN SIGNAL CONNECTOR

Designation	79 w/tilt	79 w/o tilt	82 RWD w/o tilt	82 RWD w/tilt
Stop Light	Wht	Wht	Wht	Wht
RR Turn Signal	Dk.Grn	Brn	Brn/Red	Brn/Red
LR Turn Signal	Ylw	Dk.Grn	Dk.Grn/Red	Dk.Grn/Red
Turn Signal Flasher	Pur	Red	Red	Red
Hazard Signal Flasher	Brn	Pnk	Pnk	Pnk
RF Turn Signal	Dk.Blu	Tan	Tan	Tan
LF Turn Signal	Lt.Blu	Lt.Grn	Lt.Grn	Lt.Grn
Horn	Blk	Blk	Blk/Red	Blk/Red
Not supported by the Painless wire harness:				
Horn	----	Blk/Red	----	----
Horn Ground	----	Blk	Blk	----
Key Alarm	Pnk	----	Blk/Lt.Blu	----
Key Alarm	Blk	----	Lt.Blu	----
R Corner Lamp	Blk/Wht	Tan/Wht	Tan/Wht	Tan/Wht
L Corner Lamp	Gry	Lt.Grn/Blk	Lt.Grn/Blk	Lt.Grn/Blk
Corner Feed Lamp	Brn	Vio	Vio	Vio

Table 9-1 Mopar Ignition and Turn Signal Wiring 2 of 2

10.0 ALL MAKES - SPECIFIC CIRCUIT CONNECTIONS

10.1 Generator Charging System. See Figure 10-1.

- 10.1.1 Connect Generator ARMATURE terminal (A) to Voltage Regulator terminal A. Connect Generator FIELD terminal (F) to Voltage Regulator terminal F. Use 14-gauge wire (color optional) for FIELD and 12-gauge wire for Armature.
- 10.1.2 Be sure both the generator and the voltage regulator are securely grounded. The voltage regulator may have a terminal for this purpose (labeled "G") or you may have to ground the regulator case.
- 10.1.3 Connect ENGINE SECTION wire #915 (red) to Voltage Regulator terminal B.
- 10.1.4 Insulate and stow ENGINE SECTION wire #914 (wht).

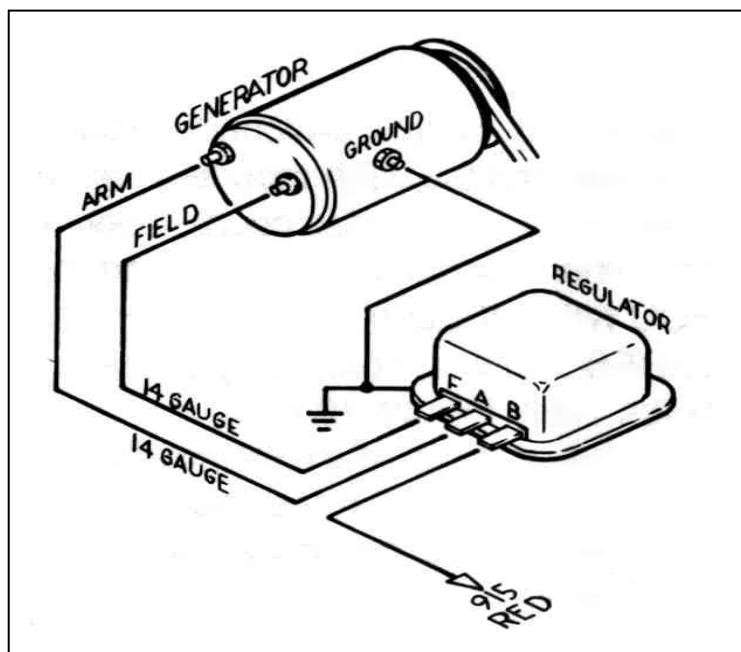

Figure 10-1 Generator Charging System

10.2 Generator to Alternator Conversion

- 10.2.1 You may be able to convert your generator charging system to use an alternator and external regulator without altering or re-routing existing wires.
- 10.2.2 Install the new alternator and replace the existing generator voltage regulator with the new, alternator compatible one.
- 10.2.3 Connect the existing wiring according to either **Section 7.0, 8.0** or **9.0**, as appropriate.

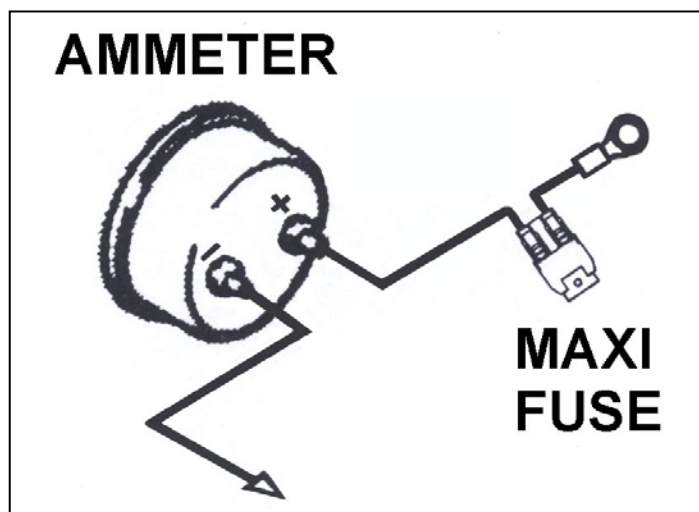

Figure 10-2 Ammeter & Maxi Fuse

10.3 Connecting an Ammeter and the Maxi Fuse. See Figure 10-2.

- 10.3.1 Most, but not all Ammeters must be inserted IN SERIES onto the ENGINE SECTION (single) 10-gauge wire #916 (red) that routes from the Fuse Panel to the Starter Solenoid on GM (**Section 7.4**) and from the Fuse Panel to the Starter Relay on Ford (**Section 8.2**) and Mopar (**Section 9.2**).
- 10.3.2 The overall physical length of this circuit should be as short as possible (allow some slack, however). You may have to cut wire #916 and you may have to add some additional length of 10-gauge wire. USE ONLY 10-GAUGE WIRE OR LARGER.
- 10.3.3 Route wire #916 (from the Fuse Panel) and connect to the Ammeter NEGATIVE terminal. To complete the installation, follow ONE of the next three (3) paragraphs, as appropriate.
- 10.3.4 If you are using a GM starter, route the remainder of wire #916 from the Ammeter POSITIVE terminal to the Maxi Fuse terminal. Connect the other side of the Maxi Fuse (**Figure 7-3**) to the Starter Solenoid Battery (B+) terminal.
- 10.3.5 If you are using a Ford starter with a starter relay, route the remainder of wire #916 from the Ammeter POSITIVE terminal to the Maxi Fuse terminal. Connect the other side of the Maxi Fuse (**Figure 7-3**) to the Starter Solenoid Battery (B+) terminal.
- 10.3.6 If you are using a Mopar starter with a starter relay, route the remainder of wire #916 from the Ammeter POSITIVE terminal to the Maxi Fuse terminal. Connect the other side of the Maxi Fuse (**Figure 7-3**) to the Starter Solenoid Battery (B+) terminal.

CAUTION: BOTH AMMETER TERMINALS MUST ABSOLUTELY BE ISOLATED FROM GROUND. IF EITHER AMMETER TERMINAL COMES IN CONTACT WITH GROUND A HARNESS FIRE IS INEVITABLE. USE EXTREME CARE AND DILIGENCE IN CONNECTING AMMETERS.

CAUTION: BE SURE YOUR AMMETER'S CURRENT (AMPS) RATING EXCEEDS THE CURRENT OUTPUT OF YOUR ALTERNATOR. PERFECT PERFORMANCE PRODUCTS, LLC DOES NOT RECOMMEND USING ANY AMMETER RATED AT LESS THAN 65 AMPS. DO NOT USE AN AMMETER WITH ANY HIGH OUTPUT ALTERNATOR (MORE THAN 65 AMPS).

10.4 HEADLIGHT SECTION A. See Figure 10-3.

- 10.4.1 Connect HEADLIGHT SECTION A wire #924 (grn) to the Horn's hot terminal. TURN SIGNAL SECTION wire #953 (blk) was connected in the Turn Signal Connector section of these instructions. The Horn Relay is pre-wired into the Fuse Panel.
- 10.4.2 Connect HEADLIGHT SECTION A wires #908 (lt.grn) and #909 (tan) to the green and tan wires of BOTH Headlamp Connectors. Connect the black wires of the Headlamp Connectors to Chassis Ground. You should have enough wire to accomplish this. You have been supplied with two small grommets (**Figure 3-1**) should you need to pass these wires through a fender well. Don't forget to thread them onto the wires BEFORE you connect the wires.
- 10.4.3 Connect HEADLIGHT SECTION A wire #927 (brn) to ALL front Park Lights. Connect HEADLIGHT SECTION A wire #925 (blu) to the RIGHT FRONT Turn Signal. Connect wire #926 (lt.blu) to the LEFT FRONT Turn Signal.

Note: Don't confuse Park Lights with Turn Signals.

- 10.4.4 Connect HEADLIGHT SECTION A wire #901 (gry/wht) to the Electric Fan Relay. This wire is an activation wire for the relay, **NOT A POWER FEED**. The other end of wire #901 is in the ACCESSORY SECTION SWITCHES and should be connected to the electric fan switch in the dash. **Figure 10-4** shows a typical fan relay installation.

Note: The wire going to the fan in Figure 10-3 will be coming from the fan relay output terminal. Wire #901 (gry/wht) from the ACCESSORY SECTION SWITCHES is an activation wire for the fan relay.

10.4.5 Take the DIMMER SWITCH SECTION connector and connect it to your floor-mounted Dimmer Switch or column-mounted Dimmer Switch. **Figure 10-5**

Note: If you are using a headlight switch that has an output for your high beams and another for your low beams (headlight switch that has a low and a high position rather than just a single headlights on position) you will need to route the dimmer switch wires up to the headlight switch and connect the #909 (tan) to the low beam terminal, the #908 (lt.grn) to the high beam terminal and the #907 (blu/ylw) wire will not be used.

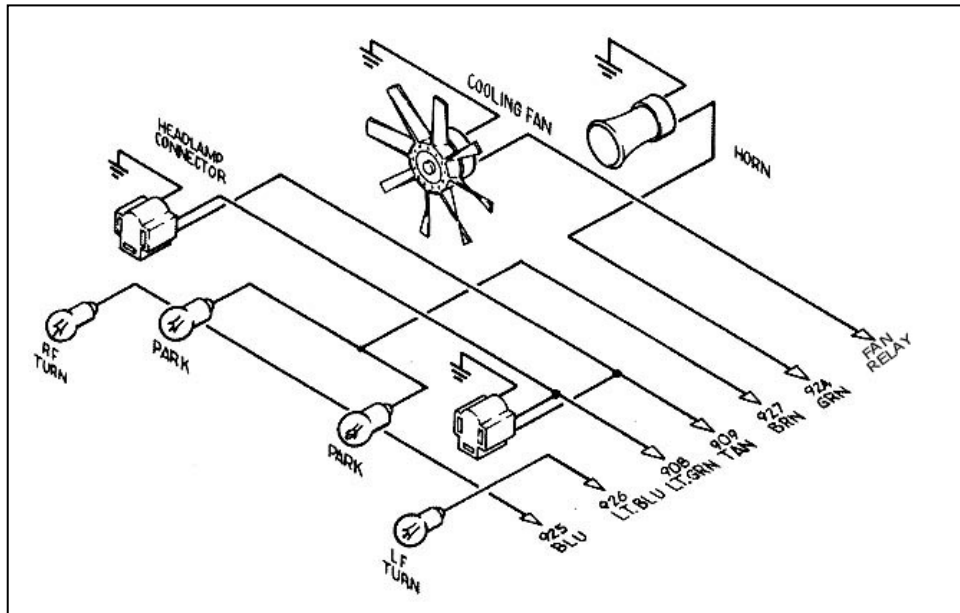

Figure 10-3 HEADLIGHT SECTION A Wiring

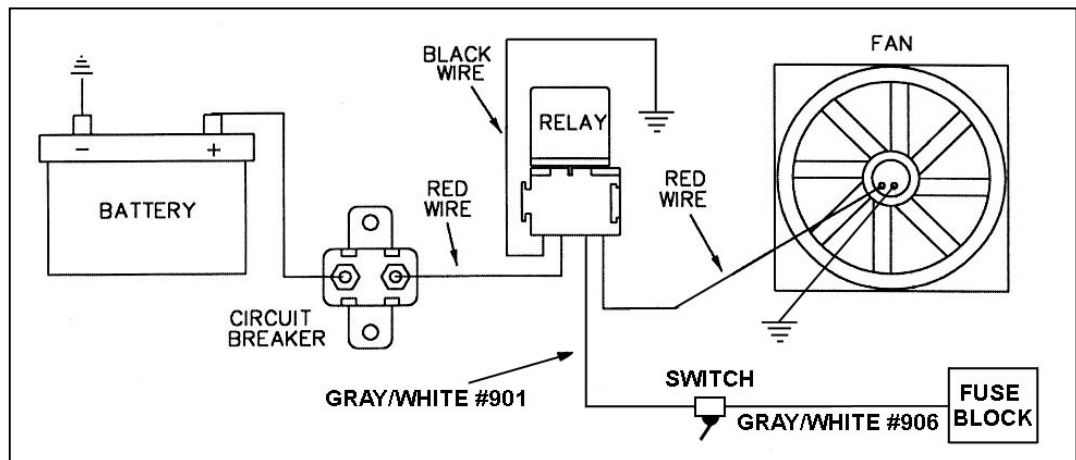

Figure 10-4 Typical Fan Relay Installation (**Fan Relay Kit - Painless Part #30101**)

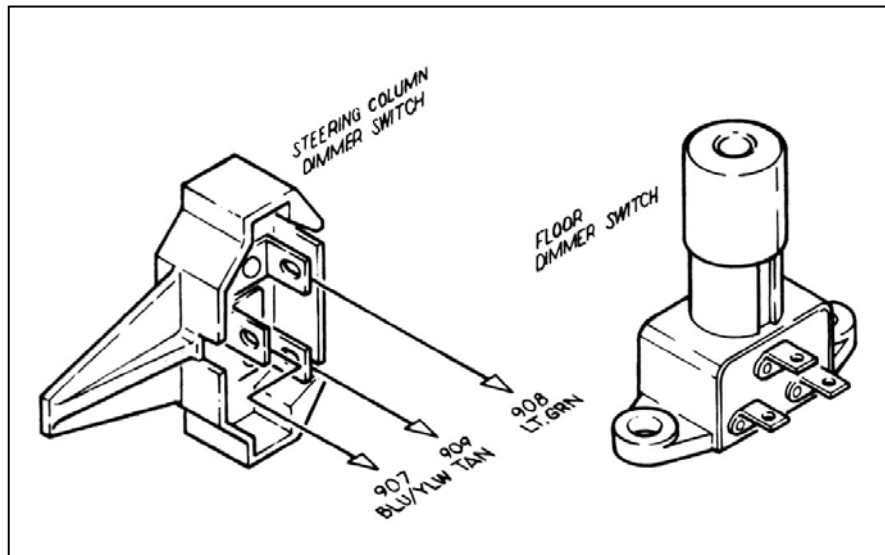

Figure 10-5 Dimmer Switches (Push-Button Style - Painless Part #80150)

10.5 HEADLIGHT SECTION B Wiring. See Figures 10-6A & 10-6B.

10.5.1 Connect the 6 wires of HEADLIGHT SECTION B as shown in the following figures. If you do not have a GM style headlight switch (**Figure 10-6A**) or the headlight switch with high/low control (**Figure 10-6B**), you should trace out the wires of your existing harness and connect the new harness according to **Table 11-2**.

Note: On late-style GM headlight switches, the park lights terminal to which wire #927 (brn) is connected (shown in **Figure 10-6A**) has been omitted. In this case, wire #927 must be connected as indicated by the dashed line in **Figure 10-6A**.

Note: On high/low style headlight switch, see note section 10.4.5 for additional wiring information.

Note: The #959 (orn) and #907 (blu/ylw) wires will not be used with the high/low style switch, insulate and stow them.

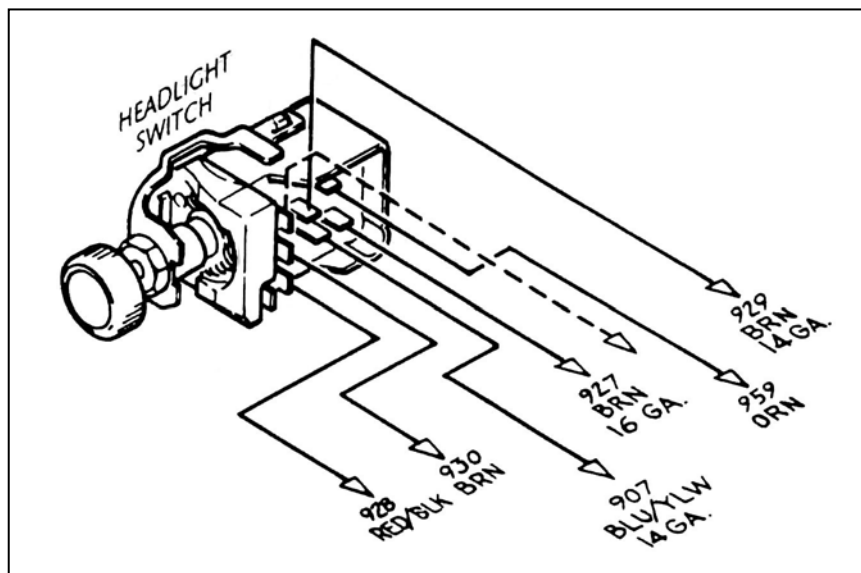

Figure 10-6A GM Style Headlight Switch (Painless Part#80152)

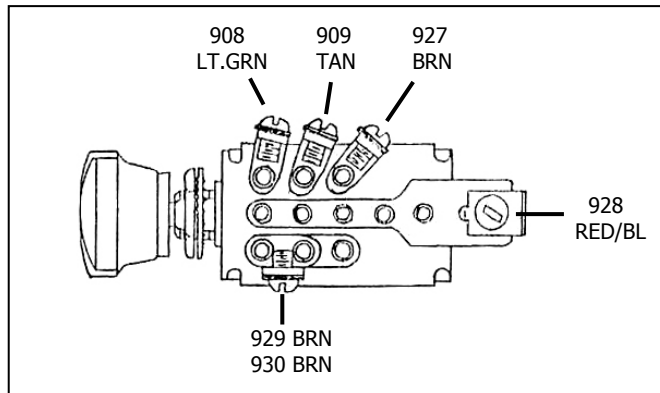

Figure 10-6B Headlight Switch with High/Low Control (**Painless Part #80154**)

10.6 Instrument Panel Wiring

- 10.6.1** Connect the wires of the INSTRUMENT PANEL SECTION as indicated in **Table 11-1**. Insulate and stow any wires you do not use.
- 10.6.2** Connect a jumper from wire #935 (red/wht) to all Gauges' power or "I" terminals. Connect a jumper from wire #930 (brn) to all Gauges' Instrument Lighting terminals. Connect a jumper to all Gauges' Ground terminals and connect to Chassis Ground.

10.7 Brake Light Switch

- 10.7.1** Connect ENGINE SECTION A wires #917 (orn) and #918 (wht) to the Brake Light Switch wherever it may be mounted.
- 10.7.2** The Third Brake Light wire is pre-connected on the Switch end. Connect TAIL SECTION wire #950 (orn) to the Third Brake Light if applicable.

10.8 Tail Section Wiring

- 10.8.1** Connect the wires of the TAIL and TURN SIGNAL SECTIONS as indicated in **Table 11-1** with the exception of #918 (wht), #948 (grn), #949 (ylw) and #950 (orn).
- 10.8.2** These 4 wires will be connected according to one of the diagrams shown in **Figure 10-7**. Which diagram you will use depends on whether or not you have one bulb on each side of the vehicle that is for the brake/tail **and** Turn Signal Lights (this is referred to as integrated lights) **or** you have **more than one** bulb on each side **and** the Brake and Turn Signal Lights are hooked to different bulbs (referred to as separate Brake/Turn Lights).

Note A: *If you have Integrated Brake Lights you must use bulbs that have two (2) filaments in them such as in an 1157 bulb.*

Note B: *The three wires shown in these diagrams are connected to the "brighter" of the two filaments when using a two-filament bulb (the Tail Lights are usually connected to the "Dimmer" filament). The Tail Lights, License Plate Lights, Reverse Lights, etc. are not shown on the diagrams for clarity.*

Note C: *In the separate Brake Light diagram the arrangement shown is only one of several ways to wire a vehicle. The important thing is that the Brake and Turn Signal Lights use completely separate bulbs.*

INTEGRATED BRAKE LIGHTS

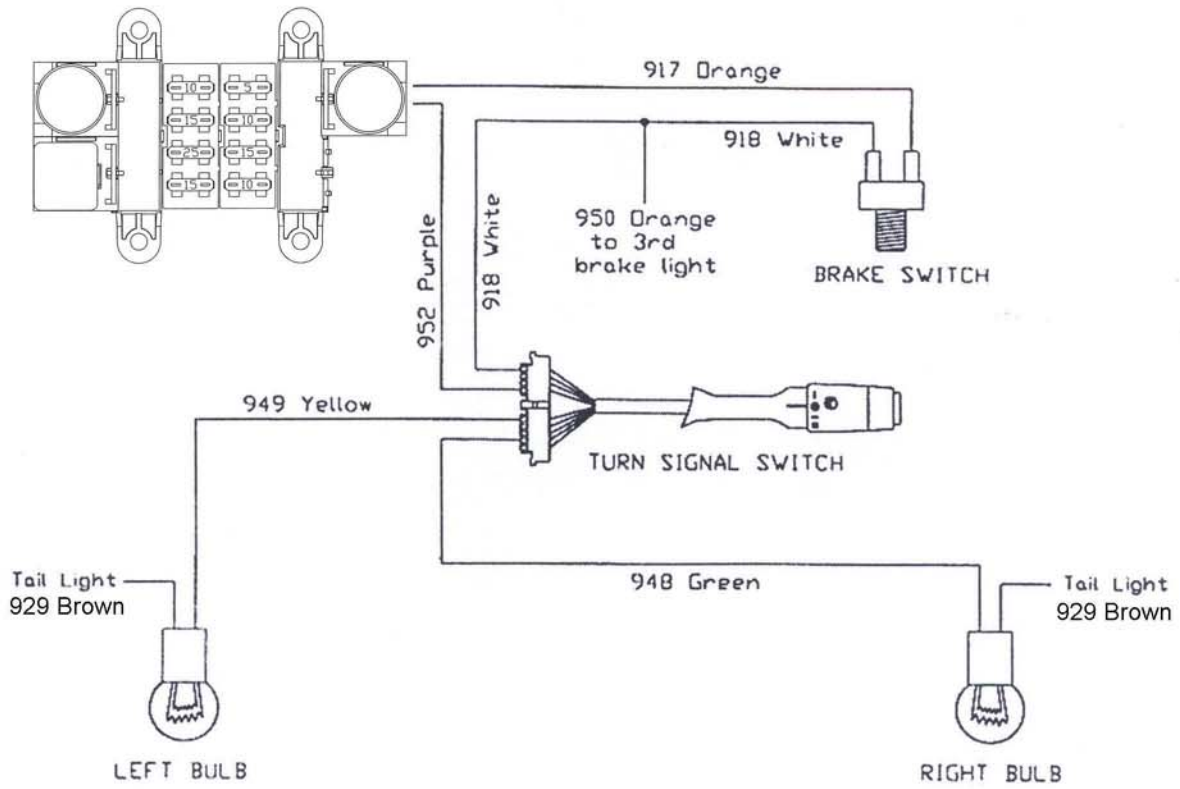

SEPARATE TURN/ BRAKE LIGHTS

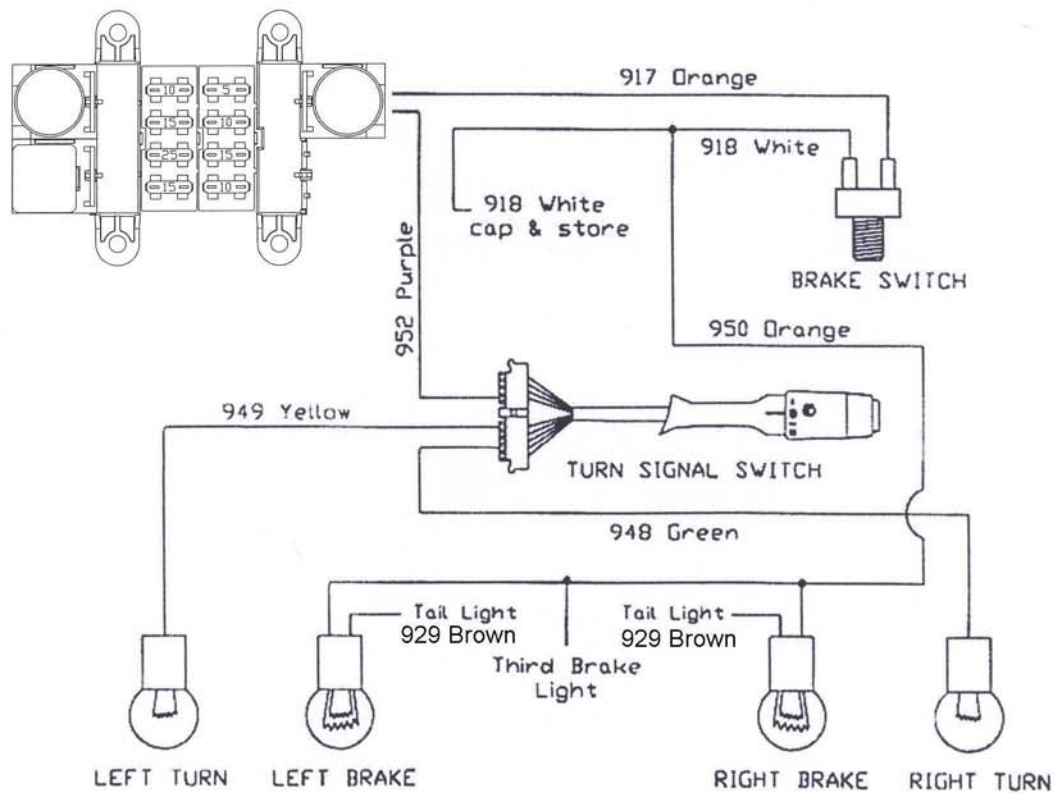

Figure 10-7 Integrated Brake Lights & Separate Turn/Brake Lights

10.9 Helpful Hints for Tail Section Wiring

- 10.9.1** When you have Integrated Brake Lights on your vehicle the Turn Signal switch acts as a brain to control when the Lights in the rear are on constantly (braking) or flashing (turning) or a combination of both. **The Turn Signal switch you use must be built to do this! If you are using a steering column out of a salvage yard that was originally in a vehicle that had separate Brake Lights then the switch will not work for Integrated Brake Lights.**
- 10.9.2** Almost all light bulbs get the ground they need through the socket housing. If you mount your socket housing into anything other than a grounded metal part then you will need to provide a separate ground wire.

11.0 WIRE CONNECTION INDEX AND FUSE REQUIREMENTS

11.1 Wire Connection Index

In each section, connect the wire, as identified by its wire color, to the appropriate item in the CONNECT TO column. Pay close attention to the **Notes** in this section, as identified by a small, raised number such as the one at the end of this sentence. ❶

Table 11-1 is divided into sections that correspond to the sections of your wire harness. (ACCESSORY SECTION B+, DIMMER SWITCH SECTION, etc.). The index is divided vertically into six columns. COLOR, GAUGE, NUMBER, CONNECT TO, ORIGIN, and SECTION OF ORIGIN.

The columns labeled ORIGIN and SECTION OF ORIGIN are for your reference ONLY. The items in these columns tell you where each wire originates (ORIGIN) and from which section (SECTION OF ORIGIN) of the harness.

The column labeled NO. contains a 900-series number that is used to identify various wires in the wiring diagrams that are a part of these instructions.

Many (but not all) of the wire numbers occur TWICE in this index. That is because you will be connecting BOTH ENDS of many of the particular wire segments. However, some wire segments are pre-connected at one end. For instance, all wires originating from the fuse panel and certain other wires such as those originating from the fuse panel and certain other wires such as those originating from the horn relay, the dimmer switch, and the instrument panel section. These pre-connected wires are identified by an asterisk (*) in the ORIGIN column.

11.2 Fuse Requirements

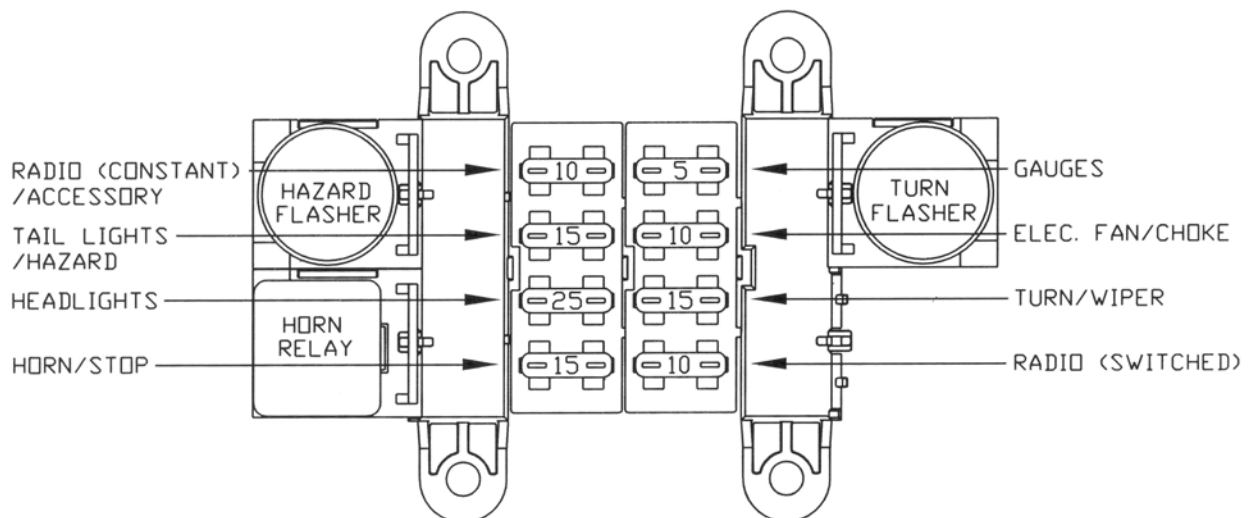

Figure 11-1 Fuse Requirements

Color	Ga.	No.	Connect to	Wire Starting Point	Section of Starting Point
ACCESSORY SECTION SWITCHES					
Gry/Wht	18	901	Cooling Fan Switch	Fan Relay	Headlight Section A
ACCESSORY SECTION B+					
Blu	16	905	Wiper Switch B+	Fuse Panel*	Fuse Panel
Gry/Wht	18	906	Cooling Fan Switch B+	Fuse Panel*	Fuse Panel
Wht	18	945	Accessory B+ (Constant Hot)	Fuse Panel*	Fuse Panel
DIMMER SWITCH SECTION					
Blu/Ylw ¹	14	907	Dimmer Switch	Headlight Switch	Headlight Section B
Lt.Grn	14	908	Dimmer Switch	High Beam	Headlight Section A
Tan	14	909	Dimmer Switch	Low Beam	Headlight Section A
ENGINE SECTION					
Wht	14	914	Alternator Exciter	Fuse Panel*	Fuse Panel
Red	10	915	Alternator B+	Fuse Panel*	Fuse Panel
Red	10	960	High Output Alternator		
ENGINE SECTION² (SINGLE WIRE)					
Red	10	916	Battery Positive or Starter Solenoid (Large Terminal)	Fuse Panel*	Fuse Panel
Red	10	960	High Output Alternator		
ENGINE SECTION A					
Orn ³	14	917	Brake Switch B+	Fuse Panel*	Fuse Panel
Wht	16	918	Brake Switch	Turn Signal Switch	Turn Signal Section
Pur	12	919	Start Solenoid ("S" Terminal)	Ignition Switch Start	Ignition Switch Section
Pnk	14	920	Coil B+	Ignition Switch	Coil B+
Lt.Grn	18	921	Temperature Sending Unit	Temperature Gauge	Instrument Panel Section
Lt.Blu/Blk	18	922	Oil Pressure Sending Unit	Oil Pressure Gauge	Instrument Panel Section
Pur/Wht	18	923	Tachometer Source	Tachometer	Instrument Panel Section
Red	18	954	Electric Choke	Fuse Panel*	Fuse Panel
HEADLIGHT SECTION A					
Grn	14	924	Horn B+	Horn Relay*	Fuse Panel
Blu	18	925	Right Front Turn Signal	Turn Signal Switch	Turn Signal Section
Lt.Blu	18	926	Left Front Turn Signal	Turn Signal Switch	Turn Signal Section
Brn	18	927	Park Lights	Headlight Switch	Headlight Switch Section
Lt.Grn	16	908	High Beam	Dimmer Switch	Dimmer Switch Section
Tan	16	909	Low Beam	Dimmer Switch	Dimmer Switch Section
Gry/Wht	18	901	Fan Relay	Fan Switch	Accy. Section Switches
HEADLIGHT SECTION B					
Red/Blk ⁷	12	928	Headlight Switch B+	Fuse Panel*	Fuse Panel
Blu/Ylw	14	907	Headlight Switch	Dimmer Switch	Dimmer Switch Section
Brn	14	929	Headlight Switch	Tail Lights	Tail Section
Brn	18	927	Headlight Switch	Park Lights	Headlight Section A
Brn ⁵	18	930	Headlight Switch	Instr. Panel Lighting	Instrument Panel Section
Orn ⁸	14	959	Headlight Switch B+	Fuse Panel*	Fuse Panel

Table 11-1 Wire Connection Index, 1 of 2

Color	Ga.	No.	Connect to	Wire Starting Point	Section of Starting Point
IGNITION SWITCH SECTION					
Pnk	14	931	Ignition Switch (Coil Ignition)	Ignition Switch	Ignition Switch Section
Brn	12	932	Ignition Switch Accessory	Ignition Switch	Ignition Switch Section
Orn	12	933	Ignition Switch Ignition	Ignition Switch	Ignition Switch Section
Red	12	934	Ignition Switch B+	Fuse Panel	Fuse Panel
Pur ⁴	12	919	Ignition Switch Start	Ignition Switch	Ignition Switch Section
INSTRUMENT PANEL SECTION					
Red/Wht	18	935	Voltmeter Source & Gauges B+	Fuse Panel	Fuse Panel
Grn	18	936	High Beam Indicator	Dimmer Switch*	Dimmer Switch Section
Lt.Blu	18	937	Left Turn Indicator	Left Front Turn Signal*	Turn Signal Section
Blu	18	938	Right Turn Indicator	Right Front Turn Sig.*	Turn Signal Section
Brn	18	930	Instrument Panel Lighting	Headlight Switch	Headlight Section B
Pnk	18	939	Fuel Gauge	Fuel Sending Unit	Tail Section
Lt. Grn	18	921	Temperature Gauge	Temp. Sending Unit	Engine Section A
Lt.Blu/Blk	18	922	Oil Pressure Gauge	Oil Pres. Sending Unit	Engine Section A
Pur/Wht	18	923	Tachometer	Tachometer Source	Engine Section A
RADIO SECTION					
Red	18	940	Radio B+ Unswitched (Constant)	Fuse Panel*	Fuse Panel
Red/Blk	18	941	Radio B+ Switched	Fuse Panel*	Fuse Panel
TAIL SECTION					
Grn	14	948	Right Rear Turn Signal	Turn Signal Switch	Turn Signal Section
Ylw	14	949	Left Rear Turn Signal	Turn Signal Switch	Turn Signal Section
Pnk	18	939	Fuel Sending Unit	Fuel Gauge	Instrument Panel Section
Brn	14	929	Tail Lights	Headlight Switch	Headlight Section B
Orn	18	950	Third Brake Light	Turn Signal Switch*	Turn Signal Section
TURN SIGNAL SECTION					
Brn	14	951	Emergency Flasher Switch B+	Emer. Flasher Relay*	Fuse Panel
Pur	14	952	Turn Signal Switch Flasher B+	Turn Flasher Relay*	Fuse Panel
Blk	18	953	Horn Switch	Horn Relay*	Fuse Panel
Grn	14	948	Turn Signal Switch	Right Rear Turn Signal	Tail Section
Ylw	14	949	Turn Signal Switch	Left Rear Turn Signal	Tail Section
Blu	18	925	Turn Signal Switch	Right Front Turn Signal	Headlight Section A
Wht	16	918	Turn Signal Switch	Brake Switch	Engine Section A
Lt.Blu	18	926	Turn Signal Switch	Left Front Turn Signal	Headlight Section A

Table 11-1 Wire Connection Index, 2 of 2

NOTES:

1. 2-color wires: 2nd color (stripe) may not be intense color. Observe two-color wires closely.
2. This section consists of two large (10 gauge) wires.
3. From fuse panel to brake switch.
4. The neutral safety switch is located at the base of General Motors and Ford steering columns and in Mopar transmissions. Do not attempt to defeat your automobile's neutral safety switch. If your automobile does not have a neutral safety switch, please install one.
5. This wire needs to go from the headlight switch to the instrument panel lights.
6. There is a Brown #932 wire and an Orange #933 wire that **MUST** be connected to the "ACC" & "IGN" terminal of the ignition switch. These wires supply all of the ignition switched power that goes to the fuse panel and both are needed because of the amount of power required to power all of the accessories.
7. This wire is power for the portion of the headlight switch that goes out to the headlights and front parking lights.
8. This wire is power for the portion of the headlight switch that goes out to the instrument panel lights and the tail lights. **NOTE: This wire is only used if your headlight switch has two power input terminals.**

INSTRUMENT PANEL SECTION WIRING

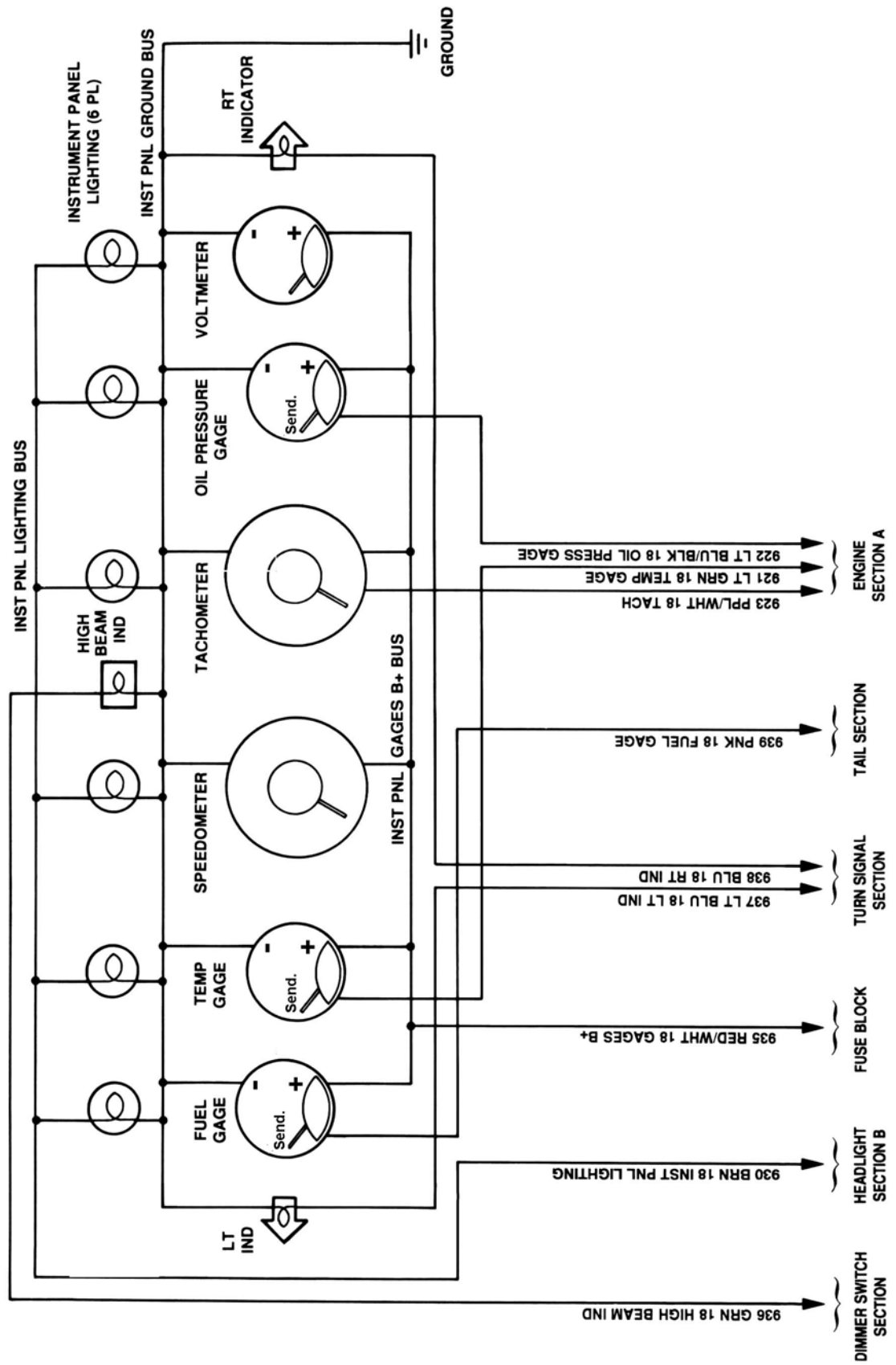

If you have any questions concerning the installation of this harness or having trouble in general, feel free to call Painless Performance Products' tech line at 1-800-423-9696. Calls are answered from 8am to 5pm central time, Monday thru Friday, except holidays.

We have attempted to provide you with as accurate instructions as possible, and are always concerned about corrections or improvements that can be made. If you have found any errors or omissions, or if you simply have comments or suggestions concerning these instructions, please write us at the address on the cover and let us know about them. Or, better yet, send us a fax at (817) 244-4024 or e-mail us at painless@painlessperformance.com. We sincerely appreciate your business.

Painless Performance Limited Warranty and Return Policy

Chassis harnesses and fuel injection harnesses are covered under a lifetime warranty.

All other products manufactured and/or sold by Painless Performance are warranted to the original purchaser to be free from defects in material and workmanship under normal use. Painless Performance will repair or replace defective products without charge during the first 12 months from the purchase date. No products will be considered for warranty without a copy of the purchase receipt showing the sellers name, address and date of purchase. You must return the product to the dealer you purchased it from to initiate warranty procedures.