

**NOT FOR USE ON AIRBAG EQUIPPED VEHICLES  
CLASSIC/CHALLENGER WHEELS ONLY**

**IF YOU HAVE A PAINTED SPOKE, YOUR WHEEL CAME WITH A SILVER FOIL DISC THAT MUST BE USED FOR PROPER HORN OPERATION. REFER TO INSTRUCTION SHEET WITH WHEEL  
DO NOT THROW AWAY!**

**SHOWN: TYPICAL CLASSIC/CHALLENGER INSTALLATION  
SEE INSTRUCTION SHEET PROVIDED WITH WHEEL FOR SIGNATURE WHEEL HORN HOOKUP.**

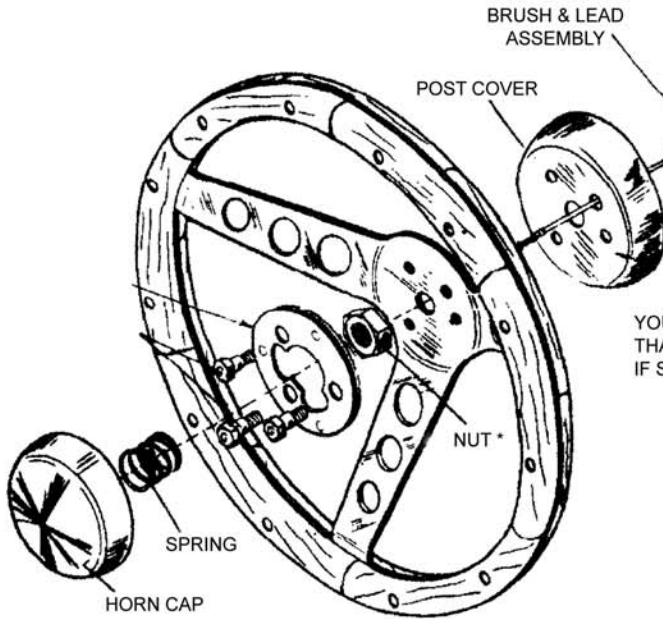

**GRANT**

**FORM #8**

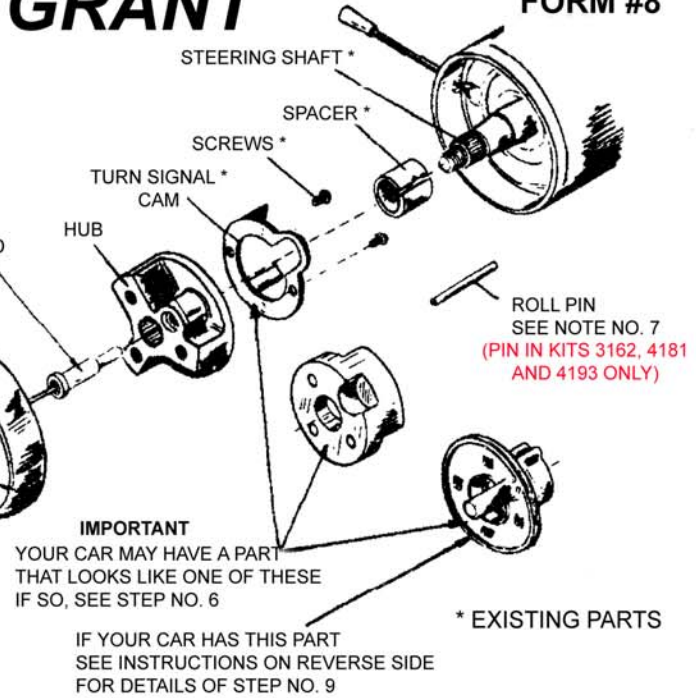

**BEFORE PROCEEDING FURTHER  
READ GENERAL NOTES AT BOTTOM**

1. Point wheels straight ahead and disconnect battery or pull horn fuse before starting removal of the old wheel so horn won't short out and blow during installation.
2. Remove horn mechanism. This is normally done by one or more of the following steps:
  - a) Press down on horn cap or ring and turn.
  - b) Remove emblem cap from its snapped-in condition by grasping it and pulling toward you, or pry loose.
  - c) Horn Ring and emblem may be secured by screws which are concealed in rear side of wheel spokes.

If one of the above operations has not removed all of the horn parts, it will have exposed the remaining screws to permit easy removal of the balance of such parts.

3. Remove nut which holds wheel to shaft.
4. Mark shaft as to which is the top of the wheel.
5. With conventional puller (or GRANT puller 5891), use the two tapped holes which you will find in the hub of old wheel to pull off the steering shaft.

If a puller is not available, you may improvise an efficient one to do the job. By drilling two holes of the proper size in a short steel bar and using two screws of the proper length you can tighten them and pull the old wheel very easily.

6. If there is a turn signal cancellation device, such as illustrated in diagram, attached to the back of your old steering wheel, remove this part and *reinstall it in the same position* on the back side of custom hub.
7. If your old steering wheel has a pin inserted in the back side, note its location. You will find a roll pin furnished in your kit. Insert this pin in the back side of custom hub using pin location of old wheel as a guide.

8. Position custom hub on splined shaft, observing that "top" is located in accordance with the mark which you made in Step No. 4.
9. Insert brush assembly in recessed hole in hub.
10. Position post cover and wheel on hub using the three shoulder bolts provided, but do not tighten at this time.
11. Check to see if wheel is in the proper position and, if correct, install the wheel retainer nut and tighten.
12. Remove shoulder bolts and reinstall same through retainer contactor ring so that the **fiber side is toward you**. Tighten shoulder bolts, connect wire lead to retainer.
13. Position spring on nut (you may find tape a help). Place horn cap in position by aligning dimples in cap with reliefs in fiber material and push until dimples pass the fiber. Turn cap left or right until tight (1/4"-1/2").
14. Reconnect battery or replace horn fuse and enjoy your new wheel.

**GENERAL NOTES**

- a) It is generally wise to apply grease to the horn contact surface on which the brush assembly rides. This will reduce wear on the parts and does not interfere with the electrical circuit.
- b) When tightening the three shoulder bolts, please keep in mind that excessive torque will result in damage to the hub. The wheel retainer nut, if properly tightened, will firmly hold hub/wheel assembly to steering shaft.

**TORQUE REQUIREMENTS  
SHOULDER BOLTS 10-12 FT/LBS  
STEERING SHAFT NUT 25-30 FT/LBS**

**On the Web: [www.grantproducts.com](http://www.grantproducts.com)**

# STEERING WHEEL INSTALLATION INSTRUCTION SUPPLEMENT

For all cars having a part  
that looks like this

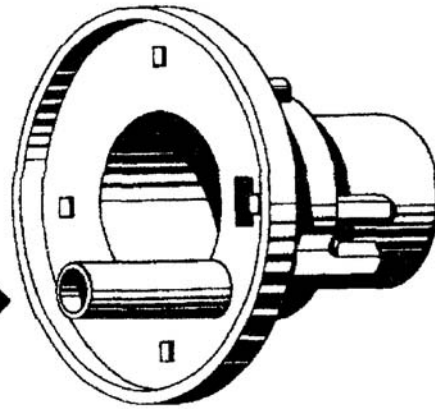

After removal of your old steering wheel, it will be necessary to remove the horn contact plunger and its spring from the plastic horn contact assembly, which should still be on your steering shaft. This horn contact plunger and spring will be replaced in the following manner:

In your kit, you will find a horn contact assembly consisting of two plastic parts, a long spring, brass plunger and a wire lead.

Separate these parts and you will use only the following in your installation:

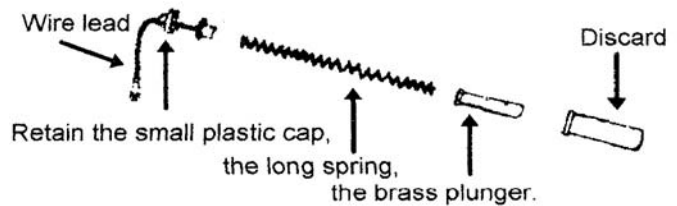
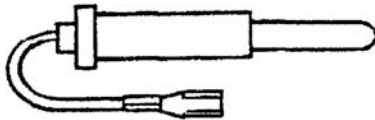

After you have secured the hub to the steering shaft and before final installation of post cover and steering wheel, you should insert the spring through the hub into your plastic horn contact assembly.

The brass plunger and cap should be placed over the spring and held in place with scotch tape so that you can complete your assembly in the usual manner.

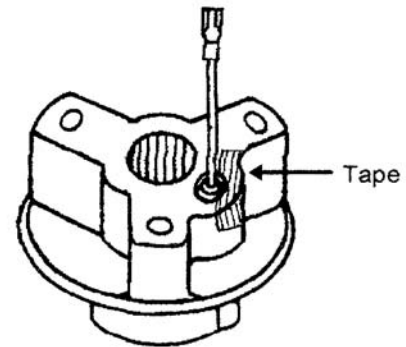
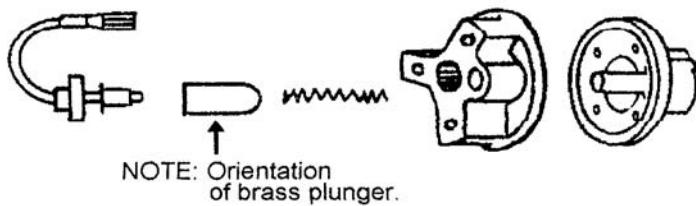

### Our Limited Warranty

We warrant this product for ninety (90) days from the date of original purchase to be free from defects in materials and workmanship. If, during this period, the product fails under normal usage because of a manufacturing defect, then we will replace or repair the item. To obtain repair or replacement under the terms of this warranty, notify us at 615 Elca Lane, Suite C, Brownsville, TX 75821. Proof of purchase and date of purchase are required to validate warranty.

All implied warranties, including warranty of merchantability, are limited to this same ninety-day period from date of original purchase. We are not liable for any direct or consequential loss or property damage arising from any use of this product. This warranty gives you specific legal rights, and you may also have other rights which vary from state to state. Offer good in U.S.A. and Canada only.

### IMPORTANT

FOR YOUR OWN SAFETY, DO **NOT** USE THIS WHEEL FOR ANY COMPETITIVE OR COMMERCIAL RACING PURPOSES: RACING DOES NOT CONSTITUTE NORMAL USAGE AND THEREFORE MAKES THIS WARRANTY VOID